



**AGENDA**  
PLACENTIA LIBRARY DISTRICT  
BOARD OF TRUSTEES  
REGULAR DATE MEETING

August 26, 2024

6:30 p.m.

Community Meeting Room

411 E. Chapman Avenue

Call-in Number: (669) 900-6833

Meeting ID: 850 1206 7452









Password: 046086

ZOOM Link: [meetings.placentialibrary.org](https://meetings.placentialibrary.org)

**Mission Statement:**

Placentia Library District inspires, opens minds, innovates, and connects our community.

**District Goals:**

-  Strengthen connections and expand community relationships.
-  Provide equitable access.
-  Adapt to community needs.
-  Cultivate thriving collections of resources.
-  Provide and promote relevant library services.
-  Maintain fiscal responsibility and integrity.
-  Support and empower staff.
-  Provide an inviting, pleasant, and safe place to explore.

**AGENDA DESCRIPTIONS:** *The Agenda descriptions are intended to give members of the public notice and a general summary of items of business to be transacted or discussed. The Board may take any action which it deems to be appropriate on the Agenda and is not limited in any way by the notice of the recommended action.*

**REPORTS AND DOCUMENTATION:** *Reports and documentation relating to Agenda items are on file in the Administrative Office and the Reference Department of Placentia Library District, and are available for public inspection. A copy of the Agenda packet will be available for use during the Board Meetings. Any person having any question concerning any Agenda item may call the Library Director at 714-528-1925, Extension 200.*

**PLEDGE OF ALLEGIANCE**      Library Board President

**CALL TO ORDER**

1. Call to Order      Library Board President
2. Roll Call      Recorder

3. Adoption of Agenda

*This is the opportunity for Board members to delete items from the Agenda, to continue items, to re-order items, and to make additions pursuant to Government Code Section 54954.2(b).*

Presentation:      Library Director

Recommendation:      Adopt by Motion

Placentia Library District Board of Trustees Regular Date Meeting Agenda, August 26, 2024

4. Oral Communications

*Members of the public may address the Library Board of Trustees on any matter within the jurisdiction of the Board. Presentations by the public are limited to 5 minutes per person. Members of the public are also permitted to address the Library Board of Trustees on specific Agenda Items before and at the time that an Item is being considered by the Board. Action may not be taken on items not on the Agenda except in emergencies or as otherwise authorized. Reference: California Government Code Sections 54954.3, 54954.2(b).*

**TRUSTEE & ORGANIZATIONAL REPORTS**

5. Board President Report - oral

*The President makes announcements of general interest to the community and the Library Board of Trustees as well as conducting any ceremonial matters.*

6. Trustee Reports

*The Trustees make announcements of general interest to the community and the Library Board of Trustees, and report on meetings attended on behalf of the Board of Trustees.*

7. Library Director Report

8. Placentia Library Friends Foundation Board of Director's Report

**CONSENT CALENDAR (Items 9 – 24)**

Presentation: Library Director

Recommendation: Approve by Motion

*Items 9 – 24 may be considered together as one motion to approve the Consent Calendar. Items may be removed for individual consideration before the Consent Calendar is adopted. Items removed must then each have a separate motion.*

**MINUTES (Item 9)**

9. Minutes of the Library Board of Trustees Regular Date Meeting on July 22, 2024. (Receive & File and Approve)

**CASH FLOW ANALYSIS (Items 10 – 11)**

10. Check Register for July 2024. (Receive & File and Approve)

11. FY2023-2024 Fund Balance through July 2024; the Schedule of Anticipated Property Tax Revenues for FY2023-2023 as provided by the Orange County Auditor. (Receive & File).

**TREASURER'S REPORTS (Items 12 – 16)**

12. Financial Reports for July 2024 for Placentia Library District Accounts on Deposit with the Orange County Treasurer. (Receive & File)

13. Revenue and Expenditure Reports for July 2024. (Receive & File)

14. Acquisitions Report for July 2024. (Receive & File)

15. Entrepreneurial Activities Report and July 2024. (Receive & File)

16. Library Impact Fee Report for July 2024. (Receive & File)

**GENERAL CONSENT REPORTS (Items 17 – 20)**

17. Personnel Report for July 2024. (Receive, File, and Ratify Appointments)

18. Review Shared Maintenance Costs with the City of Placentia under the JPA. (Receive & File)

19. Administration Report for July 2024.

20. Circulation Report for July 2024.

**STAFF REPORTS (Items 21 – 24)**



Placentia Library District Board of Trustees Regular Date Meeting Agenda, August 26, 2024

- 21. Children's Services Report for July 2024.
- 22. Adult and Teen Services Report for July 2024.
- 23. Technology and Website Report for July 2024.
- 24. Customer Service Report for July 2024.

**NEW BUSINESS (Items 25-32)**

- 25. Authorize the Placentia Library District to invest with the California Cooperative Liquid Assets Securities System (CLASS).
- 26. Authorize the Request for Proposal for Construction Services of the Outdoor Learning Experience and Loading Dock Projects.
- 27. Authorize a closure on December 5, 2024 for Staff Development Day.
- 28. Presentation of the Community Survey conducted in February – April.
- 29. Joint-Use Committee Updates from President Carline.
- 30. Roundtable Women's Club Updates from Secretary Dahl.
- 31. LAFCO Updates from Trustee Beverage.
- 32. ISDOC & Legislative Updates from Trustee Nelson.

**AGENDA DEVELOPMENT**

- 33. Agenda Preparation for the September Regular Date Meeting which will be held on September 23, 2024 unless re-scheduled by the Library Board of Trustees.

**ADJOURNMENT**

- 34. The Library Board of Trustees will adjourn the Regular Date August 26, 2024 meeting.

\*\*\*\*\*CERTIFICATION OF POSTING\*\*\*\*\*

I, Lina Nguyen, Executive Assistant of the Placentia Library District, hereby certify that the Agenda for August 26, 2024 Regular Date Meeting of the Library Board of Trustees of the Placentia Library District was posted on August 21, 2024.

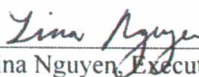
  
\_\_\_\_\_  
Lina Nguyen, Executive Assistant



Page intentionally left blank

MINUTES  
 PLACENTIA LIBRARY DISTRICT  
 REGULAR DATE MEETING OF THE LIBRARY BOARD OF TRUSTEES  
 JULY 22, 2024

**CALL TO ORDER** President Carline called the Regular Date Meeting of the Placentia Library District (PLD) Board of Trustees to order on July 22, 2024 at 6:31 p.m.

**Members Present:** President Gayle Carline, Secretary Sherri Dahl, Trustee Voiza Arnold, Trustee Stephanie Beverage.

**Members Absent:** Trustee Scott Nelson (excused).

**Staff Present:** Jeanette Contreras, Library Director; Yesenia Baltierra, Assistant Library Director; Carlo Maskarino, Business Manager; Lina Nguyen, Executive Assistant.

**Guests:** Robert Callanan, Clifton Larson Allen LLP; Laura DeLeon, Library Clerk; Jeremy Yamaguchi, IT Consultant.

**ADOPTION OF AGENDA** It was motioned by Trustee Beverage to adopt agenda as presented. It was seconded by Secretary Dahl (Item 3).

AYES: Carline, Dahl, Arnold, Beverage  
 NOES: None  
 ABSENT: Nelson

**ORAL COMMUNICATION** None (Item 4).

**BOARD PRESIDENT REPORT** President Carline reported she did not have much to report out on but she has purchased her tickets for the Taste of Placentia.

**TRUSTEE & ORGANIZATIONAL REPORTS** Secretary Dahl reported she attended the Placentia Library Friends Foundation (PLFF) Board Meeting and the Round Table Women’s Club Board Meeting. She also attended an author talk by Michael Finkel, which was set up by the Orange County Public Libraries. She reported she has been working on her candidacy paperwork.

Trustee Arnold did not have anything to report on.

Trustee Beverage reported she also purchased her tickets for the Taste of Placentia. She attended a Niche Academy webinar on privacy in libraries for both the organization and its patrons. She attended an author talk by Cara Black while on vacation. She reported she has also been working on her candidacy paperwork.

Trustee Nelson had an excused absence.

**LIBRARY DIRECTOR REPORT** Director Contreras reported she attended the City’s first Concerts in the Park. She attended a Santiago Library System special meeting regarding the Governor’s budget. The consortium will not have funds to pay for the administrative costs for the SCLC staff. The executive council voted to split it into installment payments. She reported she also attended the PLFF Board Meeting. The PLFF will be holding a reception for their members on October 25th. The committee set up for this reception will meet later this month. The PLFF will have a meeting in August to go



over strategic planning for the organization. She advised they are looking to recruit new members. She took this time to tell the Board that the upcoming Staff Appreciation Night will be on November 1st from 6:00 p.m. to 9:00 p.m. If they plan to attend, they can RSVP with Executive Assistant Nguyen.

**FRIENDS FOUNDATION REPORT**

Secretary Dahl reported out on the PLFF Board Meeting on behalf of President Gaeten Wood. The bookstore made \$2,013.85 last month. They had 285 volunteer hours. The PLFF are signing a subscription agreement for Constant Contact to work on their membership numbers. She also took this time to acknowledge Director Contreras for saving the PLFF \$243.00 after researching a bill that the PLFF received for a service that was not needed by them.

**CONSENT CALENDAR**

After a brief discussion regarding agenda items 10 and 11, it was moved by Trustee Beverage and seconded by Secretary Dahl to approve Agenda Items 9-24 as presented. A roll call vote was taken:

AYES: Carline, Dahl, Arnold, Beverage  
 NOES: None  
 ABSENT: Nelson

**MINUTES FOR JUNE 24, 2024 REGULAR DATE MEETING.**

The minutes for the June 24, 2024 Regular Date Meeting were received, reviewed and filed (Item 9).

AYES: Carline, Dahl, Arnold, Beverage  
 NOES: None  
 ABSENT: Nelson

**CASH FLOW ANALYSIS AND TREASURER’S REPORTS**

Check Registers for June 2024 (Item 10)  
 Fund 707 Balance Report for June 2024 (Item 11)  
 Financial Reports through June 2024 for Placentia Library District Accounts on Deposit with the Orange County Treasurer and Placentia Library District General Ledger: Summary of Cash and Investments (Item 12)  
 Balance Sheets for June 2024 (Item 13)  
 Acquisitions Report for June 2024 (Item 14)  
 Entrepreneurial Activities Report for June 2024 (Item 15)  
 Library Impact Fee Report for June 2024 (Item 16)

**GENERAL CONSENT REPORTS**

Personnel Report for June 2024 (Item 17)  
 Review of Shared Maintenance Costs with the City of Placentia (Item 18)  
 Administration Report for June 2024 (Item 19)  
 Circulation Report for June 2024 (Item 20)

**STAFF REPORTS**

Children’s Services Report June 2024 (Item 21)  
 Adult Services Report for June 2024 (Item 22)  
 Placentia Library Website Technology Report for June 2024 (Item 23)  
 Customer Service Report (Items 24)

**PRESENTATION OF FISCAL YEAR 2022-2023 FINANCIAL AUDIT FROM CLIFTON LARSON ALLEN LLP (CLA).**

Director Contreras introduced Robert Callanan from CliftonLarsonAllen LLP to the Board. Mr. Callanan reported out on the Fiscal Year 2022-2023 financial audit and made suggestions for future audits and answered inquiries from the Board. The Board thanked Mr. Callanan for the presentation. The Financial Audit for Fiscal Year 2022-2023 was received and will be filed.

**CALIFORNIA SPECIAL DISTRICTS ASSOCIATION (CSDA) BOARD OF DIRECTORS ELECTION – TERM 2025-2027 - SEAT A SOUTHERN NETWORK.**

Director Contreras reported the Board will need to select a candidate for the CSDA Board of Directors election for the term 25/27 for Seat A, which is the Southern Network that the District is a part of. Trustee Beverage made a motion to authorize the Library Director to submit the electronic ballot on behalf of the Placentia Library District for Jason Dafforn. It was seconded by Secretary Dahl. A roll call vote was taken:

AYES: Carline, Dahl, Arnold, Beverage  
NOES: None  
ABSENT: Nelson

**DISCUSS PROPOSAL RECEIVED FOR THE OUTDOOR SPACE AND LOADING DOCK PROJECTS AND SELECT A FIRM TO PROVIDE CONSTRUCTION SERVICES.**

Director Contreras first wanted to let the Board know this RFP was for project management vendor to oversee construction services and not an RFP for the construction services itself. An RFP for the contractors will be put out after the project management vendor has been chosen. She reported the Proposal Evaluation Committee recommended Anser Advisory for the project. However, Anser had a few objections on certain items in the form of agreement. Director Contreras will have legal counsel review the objections to see if they can be resolved. In the case they cannot be resolved, Director Contreras recommends making a motion to go with the runner-up vendor, TELACU Construction Management, tonight to avoid any delays. After a brief discussion, Trustee Beverage made a motion to approve the award of the construction management services contract to Anser Advisory up to the amount of \$222,075.00 contingent upon resolving the objections to the form of agreement between the District and Anser Advisory. It was seconded by Secretary Dahl. A roll call vote was taken:

AYES: Carline, Dahl, Arnold, Beverage  
NOES: None  
ABSENT: Nelson

Trustee Beverage made a motion, in the case that the District is unable to resolve the objections from Anser Advisory, to award the construction management services contract to TELACU Construction Management up to the amount of \$103,400.00. It was seconded by Secretary Dahl. A roll call vote was taken:

AYES: Carline, Dahl, Arnold, Beverage  
NOES: None  
ABSENT: Nelson

Trustee Beverage made a motion to delegate authority to the Library Director or her designee to make any necessary modifications to the contract agreed upon between the District and the proposer. It was seconded by Secretary Dahl. A roll call vote was taken:

AYES: Carline, Dahl, Arnold, Beverage  
NOES: None  
ABSENT: Nelson

**2023-2024 YEAR-END BUDGET REPORT.**

Director Contreras reported out on the 2023-2024 Year-End Budget Report. She advised the year ended with a surplus. The Board thanked her for the update and are glad to hear she was able to successfully end the year with a surplus.

**ADOPT RESOLUTION 2024-03: A RESOLUTION OF THE**

Director Contreras reported she is requesting to amend the Fiscal Year 2024-2025 budget due to ongoing challenges from the previous year and to complete capital



**BOARD OF TRUSTEES OF THE PLACENTIA LIBRARY DISTRICT OF ORANGE COUNTY TO AMEND THE FISCAL YEAR 2024-2025 BUDGET FOR THE PLACENTIA LIBRARY DISTRICT OF ORANGE COUNTY.**

improvement projects planned for this year. After a brief discussion, Trustee Beverage made a motion to adopt, as modified, Resolution 2024-03: A Resolution of the Board of Trustees of the Placentia Library District of Orange County to Amend the Fiscal year 2024-2025 Budget for the Placentia Library District of Orange County with the amendment to modify the budget amount from \$5,381,977.00 to \$5,410,277.00. It was seconded by Secretary Dahl. A roll call vote was taken:

- AYES: Carline, Dahl, Arnold, Beverage
- NOES: None
- ABSENT: Nelson

**APPROVE AMENDMENTS TO POLICY 2022 – EMPLOYEE OF THE YEAR BENEFITS AS PRESENTED.**

Director Contreras reported staff would like to be able to nominate substitutes/on-call personnel for Employee of the Year. Trustee Beverage made a motion to approve Amendments to Policy 2022 – Employee of the Year Benefits as presented, inclusive of input received from the Library Board of Trustees. It was seconded by Secretary Dahl. A roll call vote was taken:

- AYES: Carline, Dahl, Arnold, Beverage
- NOES: None
- ABSENT: Nelson

**JOINT-USE COMMITTEE UPDATES FROM PRESIDENT CARLINE.**

President Carline reported there was no Joint Use Meeting in June.

**ROUNDTABLE WOMEN’S CLUB UPDATES FROM SECRETARY DAHL.**

Secretary Dahl reported she attended only the Board meeting as the general club meetings are out for the Summer. The Board is preparing for the upcoming year. The dates for the soup workshop this year are August 12-14, 2024. They will go from 9:00 a.m. to 3:00 p.m. each day.

**LAFCO UPDATES FROM TRUSTEE BEVERAGE.**

Trustee Beverage reported LAFCO issued their comprehensive report at their last meeting and can be found on their website. It also reports where they are with the Municipal Service Review process. Our region is due to be looked at in 24/25. There is no specific time given. There will be an emphasis on fire emergency response, police, shared services and development of shared services systems. In addition to this, their nominations for the 24/25 CAL LAFCO election is in progress. More information is forthcoming.

**ISDOC & LEGISLATIVE UPDATES FROM TRUSTEE NELSON.**

Trustee Nelson had an excused absence. Director Contreras advised she wanted to update the Board on one legislative update. She reported initiative 1935, which would have limited the ability of government agencies to raise revenue, will not be on the November 2024 statewide ballot. The opposing team can enter in a rebuttal by July 27, 2024.

**AGENDA DEVELOPMENT**

The next Board Meeting will be on August 26, 2024 at 6:30 p.m.

**ADJOURNMENT**

President Carline took this time to mention the passing of Tommie Kalman, who was a very strong library patron and Placentia Community member. She expressed her condolences to Tommie’s sister, Marian Kalman, who is Vice President of the PLFF, and the rest of Tommie’s family. Trustee Dahl also took this time to thank



the library staff and Board for the flowers sent to her after the passing of her father over the weekend.

The Board of Trustees Regular Date Meeting of July 22, 2024 was adjourned at 7:43 p.m.

---

Gayle Carline, President  
Library Board of Trustees

---

Sherri Dahl, Secretary  
Library Board of Trustees



Page intentionally left blank

4:29 P.M.  
08/05/24  
Accrual Basis

**Placentia Library District  
Check Register  
July 2024**

Date	Ref No.	Payee	Memo	Payment	Type
07/01/2024	13796	Emcor Services - Mesa Energy	Work on AC Unit 6 and 7 & Replaced belt on AC Unit 4	1,452.50	Bill Payment
07/01/2024	13797	Pillar Designs LLC	Privacy Booth	22,182.06	Bill Payment
07/01/2024	13798	Southern California Edison	Service from 05/30/24-06/27/24	6,069.54	Bill Payment
07/01/2024	13799	UMPQUA BANK	CC Transactions 05/31/24-06/28/24	17,868.53	Bill Payment
07/01/2024	13800	U.S. Bank	Facility Lease #ISRF-18-120	57,820.88	Bill Payment
07/01/2024	13801	Pitney Bowes Purchase Power	June 2024 Statement	1,084.19	Bill Payment
07/08/2024	13802	Bridgeall Libraries Limited	ESP Basic Renewal & Professional Services Annual Renewal, Year 2 of 3	5,625.00	Bill Payment
07/08/2024	13803	OCLC, Inc.	CatExpress 06/01/24-05/31/25 & WorldShare ILL 07/01/24-06/30/25	1,329.65	Bill Payment
07/08/2024	13804	South Coast SolarClean	Solar panel cleaning	440.00	Bill Payment
07/08/2024	13805	Avocon Solutions Inc.	Consulting Services & Sonicwave 200 Series Secure License Management and Support	9,560.00	Bill Payment
07/08/2024	13806	Arcelia Janitorial Service	Janitorial Services from 06/01/24-06/30/24	4,175.00	Bill Payment
07/08/2024	13807	City of Placentia	AT&T Service from 05/01/24-05/31/24 Commercial Aquatic Services for November 2023 and Jan, Feb, Mar 2024	1,364.11	Bill Payment
07/08/2024	13808	Placentia-Yorba Linda Unified School Dist	Bus trips for Third Grade Visits - Wagner and Ruby PO 7	264.00	Bill Payment
07/08/2024	13809	Midwest Tape-Hoopla	Advance Digital Payment	2,366.00	Bill Payment
07/08/2024	13810	Califa	EBSCO - Novelist K-8 and Novelist Plus Renewal 07/01/24-06/30/25	4,130.00	Bill Payment
07/08/2024	13811	Dewey Pest Control	July through September Service	267.00	Bill Payment
07/08/2024	13812	Envisionware, Inc.	Envisionware Annual Renewal Invoice	3,518.46	Bill Payment
07/08/2024	13813	Mobile Citizen, LLC	12 month renewal for hotspots - PO 9	600.00	Bill Payment
07/08/2024	13814	Orange County Treasurer-Tax Collector	Allocation of FY 2024-2025 LAFCO Costs	3,057.22	Bill Payment
07/08/2024	13815	Placentia Chamber of Commerce	Placentia Chamber of Commerce Annual Membership Investment	341.00	Bill Payment
07/08/2024	13816	CALNET3	Service from 06/02/24-07/01/24	253.84	Bill Payment
07/08/2024	13818	Volgistics Inc.	Annual renewal with updated service level PO 10	1,236.00	Bill Payment
07/08/2024	13819	Cintas	Janitorial supplies	123.53	Bill Payment
07/08/2024	13820	SDRMA	Medical & Ancillary Benefits August 2024	30,092.19	Bill Payment
07/08/2024	13821	Placentia Library District	For payroll on 07/31/24	80,000.00	Bill Payment
07/08/2024	13822	Legacy Integrative Solutions	Service from 05/29/27-07/02/24	979.24	Bill Payment
07/08/2024	13823	Public Agency Retirement Services	Contributions for payroll on 07/03/24 & 07/17/24	2,495.20	Bill Payment
07/16/2024	13824	SDRMA	Workers' Compensation Program 24/25	20,767.74	Bill Payment
07/16/2024	13825	State of CA - Department of Justice	Fingerprint apps	32.00	Bill Payment
07/16/2024	13826	Kiwanis Club of Placentia	Kiwanis Club Membership Renewal - Margaret Hatanaka	300.00	Bill Payment
07/16/2024	13827	Newport Urgent Care Inc	Screening for new on-call library assistant CK	253.00	Bill Payment
07/16/2024	13828	Cintas	Janitorial supplies	123.53	Bill Payment
07/16/2024	13829	JV Plumbing	Replaced faucets in the employee restrooms & Fixed faucet in women's staff restroom	1,424.72	Bill Payment
07/16/2024	13830	Public Agency Retirement Services	Contributions for payroll on 07/17/24	2,606.53	Bill Payment
07/22/2024	13831	Woodruff & Smart, APC	For Services Rendered Through 06/30/24	25.50	Bill Payment



4:29 P.M.  
08/05/24  
Accrual Basis

**Placentia Library District  
Check Register  
July 2024**

07/22/2024	13832	KYA Services	Café Space remodel	28,517.34	Bill Payment
07/22/2024	13833	Charter Communications	Service from 07/12/24-08/11/24	92.19	Bill Payment
07/22/2024	13834	Johnson Controls Security Solutions	Service from 08/01/24-10/31/24	1,177.16	Bill Payment
07/22/2024	13835	Eagle Multi Media Productions	June IT Support Services	8,063.67	Bill Payment
		Emcor Services - Mesa			
07/22/2024	13836	Energy	Replaced parts on AC Unit 6	3,900.00	Bill Payment
07/22/2024	13837	SoCalGas	Service from 06/14/24-07/16/24	49.66	Bill Payment
07/22/2024	13838	Cintas	Janitorial Supplies	195.30	Bill Payment
07/22/2024	13839	Placentia Library District	For payroll on 08/14/24	80,000.00	Bill Payment
07/22/2024	13840	Jack Morris	Wild Wednesday performer 08/07/24 PO 22	375.00	Bill Payment
<b>TOTAL</b>				<b>\$ 406,598.48</b>	

**PLACENTIA LIBRARY DISTRICT BOARD OF TRUSTEES**

**TO:** Library Board of Trustees

**FROM:** Carlo Maskarino, Business Manager

**SUBJECT:** **Fund Balance Report through July 2024 for Placentia Library District Fund 9LX with Orange County Treasurer**

**DATE:** August 26, 2024

<b>Fiscal Year 2024-2025</b>	
7/31/2024	852,276.28
8/31/2024	
9/30/2024	
10/31/2024	
11/30/2024	
12/31/2024	
1/31/2025	
2/28/2025	
3/31/2025	
4/30/2025	
5/31/2025	
6/30/2025	

<b>Fiscal Year 2023-2024</b>	
7/31/2023	817,970.90
8/31/2023	820,434.59
9/30/2023	822,916.52
10/31/2023	825,542.53
11/30/2023	828,237.08
12/31/2023	830,976.37
1/31/2024	833,921.08
2/28/2024	836,851.01
3/31/2024	839,963.27
4/30/2024	843,034.60
5/31/2024	846,053.98
6/30/2024	849,150.81



Page intentionally left blank



---



---

**PLACENTIA LIBRARY DISTRICT BOARD OF TRUSTEES**

---



---

**TO:** Library Board of Trustees

**FROM:** Carlo Maskarino, Business Manager

**SUBJECT:** **Financial Reports through July 2024 for the Placentia Library District Accounts on Deposit with the Orange County Treasurer and the Placentia Library District General Ledger**

**DATE:** August 26, 2024

**Summary of Cash and Investments as of July 31, 2024**

Cash with Orange County Treasurer Fund 9LX	\$	<b>852,276.28</b>
General Fund Checking – BMO	\$	<b>595,575.88</b>
General Fund Savings – BMO	\$	<b>2,624,068.52</b>
<i>(Impact Fees in Savings – Restricted)</i>	\$	<i>874,140.68</i>
Payroll Checking – Wells Fargo Bank	\$	<b>173,059.55</b>
<b>Total Cash and Investments</b>	<b>\$</b>	<b>4,244,980.23</b>

I hereby certify that the investments are in compliance with Placentia Library District Policy 3035 – Investment of District Funds, as adopted by the Library Board of Trustees, and California Government Code Section 53646(b)(1); and that Placentia Library District has the ability to meet its budgeted expenditures for the next six (6) months.

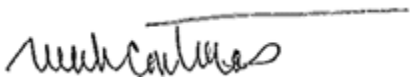

Jeanette Contreras  
Library Director



Page intentionally left blank

**PLACENTIA LIBRARY DISTRICT**  
**YTD REVENUE REPORT**  
**AS OF JULY 31, 2024**

Acct #	DESCRIPTION	BUDGET	YTD ACTUAL	BALANCE	PERCENT % RECEIVED
<b>PROPERTY TAX REVENUE</b>					
4010	Property Taxes - Current Secured	3,322,916	24,141	(3,298,775)	0.7%
4020	Property Taxes - Current Unsecured	94,378	0	(94,378)	0.0%
4050	Property Taxes - Curr Supplemental	87,057	8,250	(78,807)	9.5%
4070	Interest on Unapport Tax	670	0	(670)	0.0%
4080	Penalties & Costs on Delinq Taxes	22,445	28,373	5,928	126.4%
4090	Taxes Special Dist Augmentation	10,065	0	(10,065)	0.0%
* 4180	Other Revenue	0	0	0	-
4190	State - Homeowners Property Tax Relief	12,760	0	(12,760)	0.0%
	<b>Sub Total</b>	<b>3,550,291</b>	<b>60,763</b>	<b>(3,489,528)</b>	<b>1.7%</b>
<b>INTEREST REVENUE</b>					
4600	Interest	33,966	3,125	(30,841)	9.2%
	<b>Sub Total</b>	<b>33,966</b>	<b>3,125</b>	<b>(30,841)</b>	<b>9.2%</b>
<b>GRANT REVENUE</b>					
4210	State Grants	140,000	0	(140,000)	0.0%
4220,4230	Fed/Other Grants	5,000	0	(5,000)	0.0%
	<b>Sub Total</b>	<b>145,000</b>	<b>0</b>	<b>(145,000)</b>	<b>0.0%</b>
<b>MISCELLANEOUS REVENUES</b>					
4410	PLFF Grants	38,000	0	(38,000)	0.0%
4310	Fines & Fees	15,357	1,456	(13,901)	9.5%
4320, 4330	Passport/Photos	244,170	20,260	(223,910)	8.3%
4340	Meeting Room Fees	1,260	0	(1,260)	0.0%
* 4430	Other: Miscellaneous	3,500	0	(3,500)	-
	<b>Sub Total</b>	<b>302,287</b>	<b>21,716</b>	<b>(280,571)</b>	<b>7.2%</b>
<b>TOTAL REVENUES YTD FOR FY 23/24:</b>		<b>4,031,544</b>	<b>85,604</b>	<b>(3,945,940)</b>	<b>2.1%</b>
<b>CASH, INVESTMENTS, &amp; LIBRARY IMPACT FEES</b>					
<b>BEGINNING BALANCE</b>		<b>4,698,582</b>	<b>4,244,980</b>	<b>(453,601)</b>	
4500	Cash/Investments	874,141	874,141	0	
	Impact Fees - Restricted Funds				

\* Mathematically unable to divide by zero.

PLACENTIA LIBRARY DISTRICT  
EXPENDITURES REPORT  
as of July 31, 2024

8% of the year completed.

ACCOUNT	DESCRIPTION	APPROPRIATIONS	EXPENDED	CURRENT REMAINDER
<b>SALARIES &amp; EMPLOYEE BENEFITS</b>				
5010, 5020	Salaries & Wages	1,960,000	223,099	0.11
5030	Retirement & Post Employment Trust 115	72,801	7,707	0.11
5040	Unemployment Insurance	5,000	0	0.00
5050	Health Insurance	332,574	26,926	0.08
5060	Life Insurance	4,720	369	0.08
5064	Dental Insurance	10,960	644	0.06
5066	AD & D Insurance	6,083	454	0.07
5068	Vision Insurance	2,529	186	0.07
5070	Workers' Compensation Insurance	34,332	1,731	0.05
5090	Education Assistance Program	0	0	0.00
<b>TOTAL</b>		<b>\$2,428,999</b>	<b>\$261,115</b>	<b>0.11</b>
<b>SERVICES &amp; SUPPLIES</b>				
5099	Property & Liability Insurance	78,454	6,585	0.08
5100-5140	Communications, Internet, Cable	60,000	346	0.01
5150-5180	Janitorial Supplies & Services	95,800	5,956	0.06
5160	Refuse Disposal	3,500	486	0.14
5205	Maintenance Equipment	19,384	1,904	0.10
5200, 5210-5280	Building Maintenance	150,000	8,564	0.06
5290-5292	Memberships	13,000	1,323	0.10
5300-5450,5350	Office Expenses & Postage	85,000	5,906	0.07
5400-5480	Prof./Specialized Services	278,300	15,311	0.06
5490	Loan Obligation (f:bank)	73,900	57,821	0.78
5495, 5910, 5920	Programs, PLFP Grant, Fed & State Grant	51,285	2,046	0.04
5500	Books/Library Materials	320,000	23,025	0.07
5600	Travel & Meetings/Professional Development	55,000	679	0.01
5700	Mileage/Parking	1,000	0	0.00
5800	Utilities	83,177	11,782	0.14
5900	Bookmobile - Vehicle	200,000	0	0.00
5901	Bookmobile - Collection	90,000	0	0.00
5902	Bookmobile - Supplies & Materials	10,000	0	0.00
5904	Bookmobile - Other	5,000	0	0.00
6000	Other	1,200,000	2,681	0.00
<b>TOTAL</b>		<b>\$2,872,800</b>	<b>\$144,415</b>	<b>0.05</b>
<b>OPERATING EXPENSES</b>		<b>\$5,301,799</b>	<b>\$405,530</b>	<b>0.08</b>
<b>FIXED ASSETS &amp; TAXES</b>				
1310	Building Improvements	85,500	0	0.00
1320	Equipment & Furniture	10,000	0	0.00
2500	Capital Lease	73,844	0	0.00
6100	Taxes and Assessments	13,034	0	0.00
<b>TOTAL</b>		<b>\$182,378</b>	<b>\$0</b>	<b>0.00</b>
<b>TOTAL BUDGET</b>		<b>\$5,484,177</b>	<b>\$405,530</b>	<b>0.07</b>
				<b>\$5,078,647</b>



**PLACENTIA LIBRARY DISTRICT BOARD OF TRUSTEES**

---

**TO:** Jeanette Contreras, Library Director

**FROM:** Yesenia Baltierra, Assistant Library Director

**SUBJECT:** **Acquisitions Report for July 2024**

**DATE:** August 26, 2024

**MONTHLY STATISTICS**

Total Budget	FY 2024-25	% Spent	FY 2023-24	% Spent
<b>Library</b>	<b>\$350,620.00</b>	<b>12%</b>	<b>\$350,620.00</b>	<b>12%</b>
<b>Bookmobile</b>	<b>\$90,000</b>	<b>0%</b>	<b>70,000</b>	<b>0%</b>

Collection Expenditures	Month	July	FY-T-D	FY-T-D	FY-T-D
	2024	2023	2024-25	2023-24	% changed
Print Materials	\$6,310	\$6,240	\$6,310	\$6,240	1%
Print Serial Subscription	\$1,468	\$1,141	\$1,468	\$1,141	29%
Audio Materials	\$540	N/A	\$540	N/A	N/A
Video Materials	\$563	N/A	\$563	N/A	N/A
LOTS	\$1,200	\$2,194	\$1,200	\$2,194	-45%
<b>Total Physical Materials</b>	<b>\$10,080</b>	<b>\$9,575</b>	<b>\$10,080</b>	<b>\$9,575</b>	<b>5%</b>
Digital eBooks	\$3,345	\$7,360	\$3,345	\$7,360	-55%
Digital eAudiobooks	\$5,374	N/A	\$5,374	N/A	N/A
Other Digital	\$1,718	N/A	\$1,718	N/A	N/A
Databases	\$19,982	\$23,593	\$19,982	\$23,593	-15%
<b>Total Electronic Content</b>	<b>\$30,420</b>	<b>\$30,953</b>	<b>\$30,420</b>	<b>\$30,953</b>	<b>-2%</b>
Bookmobile Print Materials	\$0	N/A	\$0	N/A	N/A
Bookmobile Digital	\$0	N/A	\$0	N/A	N/A
Bookmobile LOTS	\$0	N/A	\$0	N/A	N/A
<b>Total Bookmobile</b>	<b>\$0</b>	<b>\$0</b>	<b>\$0</b>	<b>\$0</b>	<b>N/A</b>
<b>Total Collection Expenditures</b>	<b>\$40,500</b>	<b>\$40,528</b>	<b>\$40,500</b>	<b>\$40,528</b>	<b>0%</b>

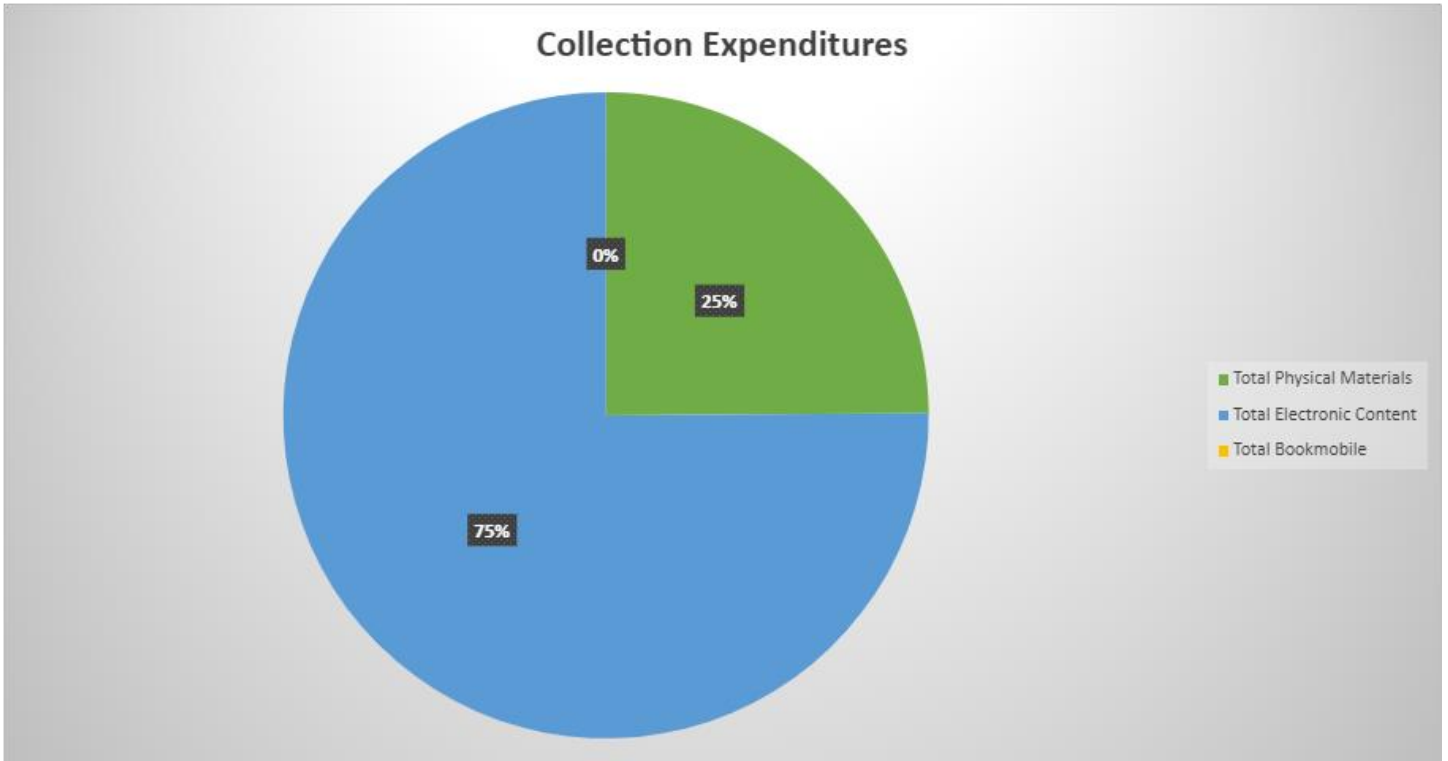

<b>Titles Added</b>	<b>July 2024</b>	<b>July 2023</b>	<b>FY-T-D 2024-25</b>	<b>FY-T-D 2023-24</b>	<b>FY-T-D % changed</b>
Print Materials	118	267	118	267	-56%
Print Serial Subscription	2	1	2	1	100%
Audio Materials	0	N/A	0	N/A	N/A
Video Materials	0	N/A	0	N/A	N/A
LOTs	0	0	0	0	N/A
<b>Total Physical Materials</b>	<b>120</b>	<b>268</b>	<b>120</b>	<b>268</b>	<b>-55%</b>
Digital eBooks	1,230	3,753	1,230	3,753	-67%
Digital eAudiobooks	1,947	N/A	1,947	N/A	N/A
Other Digital	727	N/A	727	N/A	N/A
Databases	4	4	4	4	0%
<b>Total Electronic Content</b>	<b>3,908</b>	<b>3,757</b>	<b>3,908</b>	<b>3,757</b>	<b>4%</b>
Bookmobile Print Materials	0	N/A	0	N/A	N/A
Bookmobile LOTs	0	N/A	0	N/A	N/A
<b>Total Bookmobile</b>	<b>0</b>	<b>N/A</b>	<b>0</b>	<b>N/A</b>	<b>N/A</b>
<b>Total Titles Added</b>	<b>4,028</b>	<b>4,025</b>	<b>4,028</b>	<b>4,025</b>	<b>0%</b>

<b>All Materials Held</b>	<b>July</b>	<b>June</b>	<b>Month to Month</b>
	<b>2024</b>	<b>2024</b>	<b>% changed</b>
<b>Total Library Physical</b>	81,966	82,676	-1%
<b>Total Digital</b>	1,968,969	1,900,783	4%
<b>Total Bookmobile Physical</b>	0	N/A	N/A
<b>Total All Materials</b>	2,050,935	1,983,459	3%

<b>Library Children's Physical Materials Held</b>	<b>July</b>	<b>June</b>	<b>Month to Month</b>
	<b>2024</b>	<b>2024</b>	<b>% change</b>
Children's Fiction	23,237	23,280	0%
Children's Nonfiction	13,963	13,977	0%
Children's Spanish	3,359	3,347	0%
Children's Audiobook	898	827	9%
Children's DVD/Video	1,697	1,614	5%
Children's LOTs	63	64	-2%
<b>TOTAL</b>	<b>43,217</b>	<b>43,109</b>	<b>0%</b>

<b>Library Adult/Teen Physical Materials Held</b>	<b>July</b>	<b>June</b>	<b>Month to Month</b>
	<b>2024</b>	<b>2024</b>	<b>% change</b>
Adult Fiction	16,836	16,803	0%
Adult Nonfiction	12,762	12,751	0%
Adult Foreign Language	1,302	1,303	0%
Adult Audiobook	1,324	1,324	0%
Adult DVD/Video	3,047	3,044	0%
Adult LOTs	147	148	-1%
Vinyl Records	184	174	6%
Video Games	412	399	3%
Teen Fiction	2,735	2,815	-3%
<b>TOTAL</b>	<b>38,749</b>	<b>38,761</b>	<b>0%</b>

<b>Digital Material Held</b>	<b>July</b>	<b>June</b>	<b>Month to Month</b>
	<b>2024</b>	<b>2024</b>	<b>% change</b>
eBooks	1,125,367	1,070,389	5%
Digital Audiobooks	264,206	257,179	3%
Digital Videos	109,800	108,060	2%
Digital Magazines	4,192	4,186	0%
Digital Music	465,404	460,958	1%
Databases	9	11	-18%
<b>TOTAL</b>	<b>1,968,978</b>	<b>1,900,783</b>	<b>4%</b>



**PLACENTIA LIBRARY DISTRICT BOARD OF TRUSTEES**

**TO:** Library Board of Trustees

**FROM:** Carlo Maskarino, Business Manager

**SUBJECT:** Service Revenue Activities Report for July 2024

**DATE:** August 26, 2024

**Net Revenue Summary for July 2024**

			YTD	YTD
	Jul-24	Jul-23	2024-2025	2023-2024
Passport	14,660	10,430	14,660	10,430
Passport Photos	5,600	3,900	5,600	3,900
Fines & Fees	1,456	785	1,456	785
Meeting Room	0	0	0	0
<b>TOTAL</b>	<b>\$ 21,716</b>	<b>\$ 15,115</b>	<b>\$ 21,716</b>	<b>\$ 15,115</b>



Page intentionally left blank

---



---

**PLACENTIA LIBRARY DISTRICT BOARD OF TRUSTEES**

---



---

**TO:** Library Board of Trustees

**FROM:** Carlo Maskarino, Business Manager

**SUBJECT:** Library Impact Fee Report – July 2024

**DATE:** August 26, 2024

<b>Total Monthly Fees Collected</b>			YTD	YTD
	Jul-24	Jul-23	2024-2025	2023-2024
	\$0.00	\$27,064.80	\$0.00	\$27,064.80

<b>Development Projects List</b>
----------------------------------

Developer/Builder Name	Project Description	Address	Sq. Ft	Fee Paid to Library	Date

2024/2025 YTD Total	\$0.00
Beginning Balance (7/01/2024)	\$ 874,140.68
Ending Balance (07/31/2024)	\$874,140.68



Page intentionally left blank



---



---

**PLACENTIA LIBRARY DISTRICT BOARD OF TRUSTEES**

---



---

**TO:** Library Board of Trustees

**FROM:** Carlo Maskarino, Business Manager

**SUBJECT:** Personnel Report for July 2024

**DATE:** August 26, 2024

			YTD	YTD
	Jul-24	Jul-23	2024-2025	2023-2024
Separation	0	0	0	0
Retirement	0	0	0	0
Appointments	0	0	0	0
Open Positions	1	3	1	3
Workers' Compensation Leave	0	0	0	0
<b>TOTAL</b>	1	3	1	3

**SEPARATION:**

None

**RETIREMENT:**

None

**APPOINTMENTS:**

None

**OPEN POSITIONS:**

Librarian I – Adult FT

**WORKERS COMPENSATION LEAVE:**

None



Page intentionally left blank

**PLACENTIA LIBRARY DISTRICT BOARD OF TRUSTEES**

**TO:** Library Board of Trustees  
**FROM:** Carlo Maskarino, Business Manager  
**SUBJECT:** City of Placentia - Shared Maintenance Costs through July 2024  
**DATE:** August 26, 2024

**CITY OF PLACENTIA INVOICES**

PERIOD COVERED	INVOICE DATE	TURF (Merchants)	GROUNDS (SA Aquatics)	AT&T	FACILITY MAINT	TOTAL
FY 2024-2025						
Jul-24	7/22/2024	1,519.81	582.40	0.00	0.00	2,102.21
Aug-24						
Sep-24						
Oct-24						
Nov-24						
Dec-24						
Jan-25						
Feb-25						
Mar-25						
Apr-25						
May-25						
Jun-25						
	<b>TOTAL</b>	<b>\$1,519.81</b>	<b>\$582.40</b>	<b>\$0.00</b>	<b>\$0.00</b>	<b>\$2,102.21</b>

\* City Billing Not Received

PERIOD COVERED	INVOICE DATE	TURF (Merchants)	GROUNDS (SA Aquatics)	AT&T	FACILITY MAINT	TOTAL
FY 2023-2024						
Jul-23	7/25/2023	3,310.12	287.04	20.20	0.00	3,617.36
Aug-23	8/31/2023	0.00	291.20	0.00	0.00	291.20
Sep-23	9/26/2023	0.00	291.20	21.06	274.17	586.43
Oct-23	*	*	*	*	*	*
Nov-23	11/6/2023	0.00	900.00	10.26	0.00	910.26
Dec-23	12/15/2023	0.00	582.40	11.95	760.03	1,354.38
Jan-24	1/31/2024	321.16	540.80	24.95	0.00	886.91
Feb-24	*	*	*	*	*	*
Mar-24	3/5/2024	11,837.34	0.00	24.43	37.18	11,898.95
Apr-24	*	*	*	*	*	*
May-24	5/16/2024	1,519.81	0.00	24.27	0.00	1,544.08
Jun-24	6/26/2024	0.00	1,352.00	12.11	0.00	1,364.11
	<b>TOTAL</b>	<b>\$16,988.43</b>	<b>\$4,244.64</b>	<b>\$149.23</b>	<b>\$1,071.38</b>	<b>\$22,453.68</b>



Page intentionally left blank

---

---

**PLACENTIA LIBRARY DISTRICT BOARD OF TRUSTEES**

---

---

**TO:** Library Board of Trustees

**FROM:** Jeanette Contreras, Library Director

**SUBJECT:** **Administration Report for July 2024**

**DATE:** August 26, 2024

**Meetings:**

- July 2nd, PYLUSD Internship Partnership Meeting: Assistant Library Director and staff met with George Key & Venture Academy Principle Rebecca Allan and teacher Ms. Carmen to discuss the details of the internship and start date of July 15th.
- July 11th, Meeting with President Carline: Library Director
- July 15th, Santiago Library System Executive Council Meeting: Library Director
- July 15th, PLFF Board Meeting: Library Director
- July 17th, CLA Nominating Committee Meeting: Assistant Library Director met with the committee to review the list of nominees. The committee was able to narrow the list down to two candidates per category.
- July 17th, RFP Selection Committee Meeting: Business Manager attended RFP Selection Committee meeting to review bid proposals and make recommendations.
- July 17th, Library Impact Fee Process Meeting: Library Director & Business Manager attended meeting with Director of Development Services Joe Lambert and Building Permit Technician Heidi Morgado to discuss changing the library impact fee process.
- July 18th, Weekly Meetings with Business Manager: Library Director
- July 22nd, Meeting with IT Consultant: Library Director
- July 23rd, All Staff Meeting: Administration
- July 24th, Meeting with PLFF Board President: Library Director
- July 24th, Meeting with Assistant Library Director re IMLS grants: Library Director
- July 25th, ISDOC Quarterly Meeting: Library Director



- July 25th, Library Impact Fee Meeting: Business Manager attended library impact fee meeting with City of Placentia's Director of Development Services, Joseph Lambert.
- July 30th, Baker & Taylor Meeting: Assistant Library Director and staff met with Baker & Taylor sales representative Jane Her to discuss the changes and impacts of the 'First Look' carts on the collection process. Staff will review options and determine the best option for the selectors.
- July 30th, PLFF Membership Reception Committee: Library Director
- July 33th – August 1st, United for Libraries Virtual Conference: Library Director
- July 31st, Placentia City Council District 1 Event: Library Director and Assistant Library Director

**PLACENTIA LIBRARY DISTRICT BOARD OF TRUSTEES**

---

**TO:** Jeanette Contreras, Library Director

**FROM:** Yesenia Baltierra, Assistant Library Director

**SUBJECT:** Circulation Activity Report for July 2024

**DATE:** August 26, 2024

<b>Children's Circulation</b>	<b>July</b>	<b>July</b>	<b>FY-T-D</b>	<b>FY-T-D</b>	<b>FY-T-D</b>
	<b>2024</b>	<b>2023</b>	<b>2024-25</b>	<b>2023-24</b>	<b>% change</b>
Children's Fiction Physical	10,731	11,828	10,731	11,828	-9%
Children's Fiction Digital	1,384	919	1,384	919	51%
<b>Children's Fiction TOTAL</b>	<b>12,115</b>	<b>12,747</b>	<b>12,115</b>	<b>12,747</b>	<b>-5%</b>
Children's Nonfiction Physical	3,184	2,943	3,184	2,943	8%
Children's Nonfiction Digital	116	85	116	85	36%
<b>Children's Non-Fiction TOTAL</b>	<b>3,300</b>	<b>3,028</b>	<b>3,300</b>	<b>3,028</b>	<b>9%</b>
Children's Magazine Digital	35	8	35	8	338%
<b>Children's Magazine TOTAL</b>	<b>35</b>	<b>11</b>	<b>35</b>	<b>11</b>	<b>218%</b>
Children's Audiobook Physical	1,068	834	1,068	834	28%
Children's Audiobook Digital	826	602	826	602	37%
<b>Children's Audiobook TOTAL</b>	<b>1,894</b>	<b>1,436</b>	<b>1,894</b>	<b>1,436</b>	<b>32%</b>
Children's DVD/Video Physical	373	467	373	467	-20%
Children's DVD/Video Digital	76	62	76	62	23%
<b>Children's DVD/Video TOTAL</b>	<b>449</b>	<b>529</b>	<b>449</b>	<b>529</b>	<b>-15%</b>
Children's LOTS	41	42	41	42	-2%
Music Digital	10	16	10	16	-38%
<b>TOTAL All Children's Physical Content</b>	<b>15,397</b>	<b>16,117</b>	<b>15,397</b>	<b>16,117</b>	<b>-4%</b>
<b>TOTAL All Children's Digital Content</b>	<b>2,447</b>	<b>1,692</b>	<b>2,447</b>	<b>1,692</b>	<b>45%</b>
<b>TOTAL All Children's Content</b>	<b>17,844</b>	<b>17,809</b>	<b>17,844</b>	<b>17,809</b>	<b>0%</b>

<b>Adult/Teen Circulation</b>	<b>July</b>	<b>July</b>	<b>FY-T-D</b>	<b>FY-T-D</b>	<b>FY-T-D</b>
	<b>2024</b>	<b>2023</b>	<b>2024-25</b>	<b>2023-24</b>	<b>% change</b>
Adult Fiction Physical	2,636	2,846	2,636	2,846	-7%
Adult Fiction Digital	3,878	2,809	3,878	2,809	38%
<b>Adult Fiction TOTAL</b>	<b>6,514</b>	<b>5,655</b>	<b>6,514</b>	<b>5,655</b>	<b>15%</b>
Adult Nonfiction Physical	1,589	1,890	1,589	1,890	-16%
Adult Nonfiction Digital	1,037	782	1,037	782	33%
<b>Adult Non-Fiction TOTAL</b>	<b>2,626</b>	<b>2,672</b>	<b>2,626</b>	<b>2,672</b>	<b>-2%</b>
Adult Magazine Digital	697	159	697	159	338%
<b>Adult Magazine TOTAL</b>	<b>697</b>	<b>175</b>	<b>697</b>	<b>175</b>	<b>298%</b>
Adult Audiobook Physical	74	149	74	149	-50%
Adult Audiobook Digital	7,047	4,211	7,047	4,211	67%
<b>Adult Audiobook TOTAL</b>	<b>7,121</b>	<b>4,360</b>	<b>7,121</b>	<b>4,360</b>	<b>63%</b>
Adult DVD/Video Physical	630	573	630	573	10%
Adult DVD/Video Digital	578	561	578	561	3%
<b>Adult DVD/Video TOTAL</b>	<b>1,208</b>	<b>1,134</b>	<b>1,208</b>	<b>1,134</b>	<b>7%</b>
Adult LOTs	113	119	113	119	-5%
State Parks Pass	71	62	71	62	15%
Vinyl Records*	86		86		
Video Games	415	371	415	371	12%
Music Digital	69	101	69	101	-32%
Teen Fiction Physical	398	405	398	405	-2%
Teen Fiction Digital	392	310	392	310	26%
<b>Teen Fiction Total</b>	<b>790</b>	<b>715</b>	<b>790</b>	<b>715</b>	<b>10%</b>
<b>TOTAL All Adult/Teen Physical Content</b>	<b>6,012</b>	<b>6,431</b>	<b>6,012</b>	<b>6,431</b>	<b>-7%</b>
<b>TOTAL All Adult/Teen Digital Content</b>	<b>13,698</b>	<b>8,933</b>	<b>13,698</b>	<b>8,933</b>	<b>53%</b>
<b>TOTAL All Adult/Teen Content</b>	<b>19,710</b>	<b>15,364</b>	<b>19,710</b>	<b>15,364</b>	<b>28%</b>

<b>All Circulation</b>	<b>July</b>	<b>July</b>	<b>FY-T-D</b>	<b>FY-T-D</b>	<b>FY-T-D</b>
	<b>2024</b>	<b>2023</b>	<b>2024-25</b>	<b>2023-24</b>	<b>% change</b>
<b>Total Circulation Physical</b>	<b>21,409</b>	<b>22,548</b>	<b>21,409</b>	<b>22,548</b>	<b>-5%</b>
<b>Total Circulation Digital</b>	<b>16,145</b>	<b>10,625</b>	<b>16,145</b>	<b>10,625</b>	<b>52%</b>
<b>Total All Circulation</b>	<b>37,554</b>	<b>33,173</b>	<b>37,554</b>	<b>33,173</b>	<b>13%</b>
<b>Non-English Language Circulation</b>	<b>1,087</b>	<b>732</b>	<b>1,087</b>	<b>732</b>	<b>48%</b>

<b>Online Database Usage</b>	<b>July</b>	<b>July</b>	<b>FY-T-D</b>	<b>FY-T-D</b>	<b>FY-T-D</b>
<i>Funded by Placentia Library District</i>	<b>2024</b>	<b>2023</b>	<b>2024-25</b>	<b>2023-24</b>	<b>% change</b>
ABC Mouse	960	1,357	960	1,357	-29%
Freegal	1,185	1,145	1,185	1,145	3%
Novelist Plus	125	29	125	29	331%
Novelist Select^	2,426		2,426		
BookFlix	191	172	191	172	11%
Scholastic Teachables	60	292	60	292	-79%
<b>TOTAL PLD DATABASE USAGE</b>	<b>4,947</b>	<b>2,995</b>	<b>4,947</b>	<b>2,995</b>	<b>65%</b>

<b>Online Database Usage</b>	<b>July</b>	<b>July</b>	<b>FY-T-D</b>	<b>FY-T-D</b>	<b>FY-T-D</b>
<i>Funded by California State Library</i>	<b>2024</b>	<b>2023</b>	<b>2024-25</b>	<b>2023-24</b>	<b>% change</b>
Brainfuse JobNow/VetNow	5	9	5	9	-44%
Brainfuse HelpNow~	0	1	0	1	
Britannica	14	8	14	8	75%
LinkedIn Learning	109	26	109	26	319%
ProQuest~	0	0	0	0	
ProQuest Culture Grams~	0	0	0	0	
Teaching Books and BookConnections	290	64	290	64	353%
National Geographic Kids (Gale)~	0	2	0	2	
Gale in Context: Environmental Studies~	0	0	0	0	
Gale Interactive: Science~	0	11	0	11	
Coursera	5	19	5	19	-74%
EBSCO LearningExpress Library~	6	0	6	0	
Northstar~	0	0	0	0	
Alexander Street*	0		0		
PebbleGo Science K-2^	2		2		
<b>TOTAL CSL DATABASE USAGE</b>	<b>431</b>	<b>140</b>	<b>431</b>	<b>140</b>	<b>208%</b>
<b>TOTAL ALL DATABASE USAGE</b>	<b>5,378</b>	<b>3,135</b>	<b>5,378</b>	<b>3,135</b>	<b>72%</b>

\*New collection for FY 23-24

^New collection for FY 24-25

~Mathematically unable to divide by zero



Page intentionally left blank

**PLACENTIA LIBRARY DISTRICT BOARD OF TRUSTEES**

---

**TO:** Jeanette Contreras, Library Director

**FROM:** Yesenia Baltierra, Assistant Library Director

**SUBJECT:** Children’s Services Report for July 2024

**DATE:** August 26, 2024

<b>Number of Programs by Type</b>	<b>July 2024</b>	<b>July 2023</b>	<b>FY-T-D 2024-25</b>	<b>FY-T-D 2023-24</b>	<b>FY-T-D % change</b>
Storytime	9	9	9	9	0%
Children's Programs	16	12	16	12	33%
Hangar	0	1	0	1	-100%
Teen Programs	3	2	3	2	50%
Self Directed	3	3	3	3	0%
Outreach	2	0	2	0	-
<b>TOTAL Children/Teen</b>	<b>33</b>	<b>27</b>	<b>33</b>	<b>27</b>	<b>22%</b>

<b>Program Attendance by Type</b>	<b>July 2024</b>	<b>July 2023</b>	<b>FY-T-D 2024-25</b>	<b>FY-T-D 2023-24</b>	<b>FY-T-D % change</b>
Storytime	422	518	422	518	-19%
Children's Programs	1,749	1,148	1,749	1,148	52%
Hangar	0	98	0	98	-100%
Teen Programs	20	26	20	26	-23%
Self Directed	267	207	267	207	29%
Outreach	100	0	100	0	-
<b>TOTAL Children/Teen</b>	<b>2,558</b>	<b>1,997</b>	<b>2,558</b>	<b>1,997</b>	<b>28%</b>

<b>The Hangar Makerspace</b>	<b>July 2024</b>	<b>July 2023</b>	<b>FY-T-D 2024-25</b>	<b>FY-T-D 2023-24</b>	<b>FY-T-D % change</b>
Hangar Activity Hour Visits	157	134	157	134	17%
Hangar Equipment In-House Use	4	4	4	4	0%

**ACHIEVEMENTS**

- Daisy Badge planned Lunch at the Library and conducted the July 10, 24, and 31 events.
- Mayli Apontti facilitated Read to the Dogs on July 1.
- Mayli Apontti planned and conducted Baby Giggles and Wiggles on July 5.
- Mayli Apontti planned and conducted Family Storytime on July 13.
- Mayli Apontti facilitated Wild Wednesdays on July 3, 10, 24, and 31 and served as the point of contact for the performers.
- Mayli Apontti conducted Lunch at the Library on July 3 and 17.
- Damean Sanz facilitated Wild Wednesday on July 17 and served as the point of contact for the performer.
- Damean Sanz helped out with Lunch at the Library and Wild Wednesdays by helping set up and tear down while also taking photos for social media on July 10, 24, and 31
- Damean Sanz planned and conducted Family Storytime on July 6 with a craft component.
- Alex Aguirre planned and conducted Luna Luna Bilingual Storytime on July 3, 10, and 17.
- Alex Aguirre facilitated Code Ninjas on July 11.
- Caitlyn Sandfer planned and coordinated PTAC on July 18.
- Caitlyn Sandfer and Damean Sanz planned and ran the Movies in the Park Fundraiser with teen volunteers on July 12 and July 26.
- Joy Ellis led Morning Meet Ups on July 5, 12, 19, 26
- Mayli Apontti served on an oral (virtual) interview panel for the Santa Ana Public Library on Thursday, July 25 for the position of Library Services Assistant.

**MEETINGS**

- July 2, Caitlyn Sandfer, Margaret Hatanaka, and Yesenia Baltierra met with Rebecca Allan and Ms. Carmen from George Key School regarding the Venture Academy internship with Placentia Library. Attendees discussed the expectations for interns, overview of tasks, and scheduling.
- July 30, Margaret Hatanaka, Michelle Meades and Yesenia Baltierra met with B & T vendor representative, Jane Herb, to discuss their new service model called selectionHQ.

**PROFESSIONAL DEVELOPMENT**

- None



---



---

**PLACENTIA LIBRARY DISTRICT BOARD OF TRUSTEES**

---



---

**TO:** Jeanette Contreras, Library Director

**FROM:** Yesenia Baltierra, Assistant Library Director

**SUBJECT:** Adult Services Report for July 2024

**DATE:** August 26, 2024

**MONTHLY STATISTICS**

<b>Number of Programs by Type</b>	<b>July</b>	<b>July</b>	<b>FY-T-D</b>	<b>FY-T-D</b>	<b>FY-T-D</b>
	<b>2024</b>	<b>2023</b>	<b>2024-25</b>	<b>2023-24</b>	<b>% change</b>
Adult Programs	1	2	1	2	-50%
History Room	0	1	0	1	-100%
Literacy	26	23	26	23	13%
General Interest	0	0	0	0	-
Self-Directed	2	1	2	1	100%
<b>TOTAL Adult</b>	<b>29</b>	<b>27</b>	<b>29</b>	<b>27</b>	<b>7%</b>

<b>Program Attendance by Type</b>	<b>July</b>	<b>July</b>	<b>FY-T-D</b>	<b>FY-T-D</b>	<b>FY-T-D</b>
	<b>2024</b>	<b>2023</b>	<b>2024-25</b>	<b>2023-24</b>	<b>% change</b>
Adult Programs	10	10	10	10	0%
History Room	0	3	0	3	-100%
Literacy	180	145	180	145	24%
General Interest	0	0	0	0	-
Self-Directed	144	54	144	54	167%
<b>TOTAL Adult</b>	<b>334</b>	<b>212</b>	<b>334</b>	<b>212</b>	<b>58%</b>

<b>History Room Activity</b>	<b>July</b>	<b>July</b>	<b>FY-T-D</b>	<b>FY-T-D</b>	<b>FY-T-D</b>
	<b>2024</b>	<b>2023</b>	<b>2024-25</b>	<b>2023-24</b>	<b>% change</b>
History Room Visitors	0	7	0	7	-100%
*Memory Lab Appointments	0	8	0	8	-100%

<b>Volunteer Hours</b>	<b>July</b>	<b>July</b>	<b>FY-T-D</b>	<b>FY-T-D</b>	<b>FY-T-D</b>
	<b>2024</b>	<b>2023</b>	<b>2024-25</b>	<b>2023-24</b>	<b>% change</b>
History Room	0	0	0	0	0%
PLFF	256	191.75	256	191.75	34%
General Library	199.55	125.5	199.55	125.5	59%
Adult Literacy	265.75	178.5	265.75	178.5	49%
PTAC	10	33	10	33	-70%
Teen Volunteers	484.05	388.28	484.05	388.28	25%
<b>Total Volunteer Hours</b>	<b>1215.35</b>	<b>528.75</b>	<b>1215.35</b>	<b>528.75</b>	<b>130%</b>
<b>FTE Equivalent</b>	<b>7.01</b>	<b>3.05</b>	<b>7.01</b>	<b>3.05</b>	<b>130%</b>

<b>Literacy</b>	<b>FY-T-D</b>	<b>FY-T-D</b>	<b>FY-T-D</b>
	<b>2024-25</b>	<b>2023-24</b>	<b>% change</b>
Adult Literacy Students	22	28	-21%
Adult ESL Students	33	11	200%
Adult Literacy Tutors	22	28	-21%
Adult ESL Tutors	32	10	220%

**ACHIEVEMENTS**

- Sally Federman coordinated Literacy Reads – Beginner Book Club on July 10, 17, 24.
- Sally Federman facilitated Literacy Reads – Int. Book Club on July 9, 16, 23, 30.
- Esther Canedo coordinated Read, Write, Speak Club on July 12, 19, 26.
- Esther Canedo facilitated ESL Conver. Class at the Whitten Center on July 9, 16, 23, 30.
- Laurel Dennis facilitated ESL Conver. Class at the Library on July 9, 16, 23, 30.
- Laurel Dennis coordinated ESL Conversation Thursday morning class at the Library on July 11, 18, 25.
- Sally Federman facilitated the Casual Conversation group on July 18.
- Esther Canedo facilitated a Leamos Class at the Whitten Center on July 16, 23.
- Sally Federman and Laurel Dennis facilitated an Outdoor Fun Day on July 19.
- Sally Federman and Laurel Dennis coordinated Kitchen Talk with Erin on July 31.

- Tim Balen gave a presentation about eBooks and Online Resources, including OverDrive/Libby, Hoopla, Novelist Plus and Novelist Select, at the staff meeting on July 23.
- Michelle Meades participated in the Alhambra City Library Interviews for a Digital Librarian 1 position on July 29.

### **MEETINGS**

- On July 9, Sally Federman attended the SCLLN in-person networking meeting. New SCLLN officers were voted in. Program recognition of successes. Topics discussed were volunteer retention and recognition, ESL activities, graceful ways to “unmatch” a tutoring pair, and transitioning to new curricula.
- On July 10 Sally Federman attended the 24-25 CLLS Information meeting. We were updated on the new information we need to keep track of and some information that we no longer need to keep track of. We will be using a new reporting system called, AmpliFund.
- On July 25 Sally Federman attended the ESL Working Group virtual meeting. Allyson Jeffredo facilitated the meeting. Shared program successes, news, and any topics coordinators wanted to talk about.
- On July 24, Megan Tolman and Tim Balen met with SirsiDynix staff for the PLD SureStart Call. Topics of the library’s OPAC catalog, discovery, technical upgrades and user accessibility options were discussed.
- On July 31, Megan Tolman trained Tim Balen about collection ordering for the graphic novel and manga collections. Topics of ordering, selecting, and using Baker & Taylor were discussed.

### **PROFESSIONAL DEVELOPMENT**

- On July 2, Tim Balen reviewed diversity, equity and inclusion (EDI) resources, articles and a webinar. These resources included reviewing resources provided by the nonprofit We Need Diverse Books.
- On July 19, Tim Balen attended the California State Library Year 11 Upgrades webinar as part of the California Library Connect program. The webinar discussed timelines and forms about bandwidth upgrades, renewals, moves and adding locations for the state’s library Internet funding program.
- On July 11, Sally Federman attended the “Beyond Numbers: A Community-Centric Approach to Volunteer Impact Data (Data from the Inside-Out).” This webinar was sponsored by VolunteerMatch. The main message was to promote personal outcomes of volunteer work instead of just the numbers.



Page intentionally left blank

**PLACENTIA LIBRARY DISTRICT BOARD OF TRUSTEES**

**TO:** Jeanette Contreras, Library Director

**FROM:** Yesenia Baltierra, Assistant Library Director

**SUBJECT:** Technology and Website Report for July 2024

**DATE:** August 26, 2024

**MONTHLY STATISTICS**

<b>Computer and Wi-Fi Usage</b>	<b>July</b>	<b>July</b>	<b>FY-T-D</b>	<b>FY-T-D</b>	<b>FY-T-D</b>
	<b>2024</b>	<b>2023</b>	<b>2024-25</b>	<b>2023-24</b>	<b>% change</b>
Children Computer Usage	346	276	346	276	25%
Children AWE Learning Usage	508	385	508	385	32%
Teen Computer Usage	134	176	134	176	-24%
Adult Computer Usage	1,047	1,121	1,047	1,121	-7%
<b>Total Computer Usage</b>	<b>2,035</b>	<b>1,958</b>	<b>2,035</b>	<b>1,958</b>	<b>4%</b>
Wi-Fi Usage	1,267	1,637	1,267	1,637	-23%
Guest Passes	93	97	93	97	-4%
Total Print Jobs	1,186	939	1,186	939	26%
Total Pages Printed	3,309	3,322	3,309	3,322	0%

<b>Website Traffic</b>	<b>July</b>	<b>July</b>	<b>FY-T-D</b>	<b>FY-T-D</b>	<b>FY-T-D</b>
	<b>2024</b>	<b>2023</b>	<b>2023-24</b>	<b>2022-23</b>	<b>% change</b>
Website visits	14,794	16,788	14,794	16,788	-12%
Page Hits	28,036	27,476	28,036	27,476	2%
Users	9,338	10,979	9,338	10,979	-15%
Pages/Session	1.90	1.53			
Avg. Session Duration	00:02:42	00:01:42			
% New Sessions	96	81			
Placentia Library Online Catalog Usage	3,188	5,530	3,188	5,530	-42%

App Usage	July	July	FY-T-D	FY-T-D	FY-T-D
	2024	2023	2024-25	2022-23	% change
App Downloads	101		101		
App Launches	1,519		1,519		
Searches	10,035		10,035		
Requests Placed	181		181		
Renewals Done	455		455		
Patron Updates	74		74		
<b>App Catalog Usage</b>	<b>10,290</b>		<b>10,290</b>		

### Technology Updates

#### Completed Projects:

- Drafted SOP's for online web portal form submissions
- New inhouse and children's catalog pages

#### Ongoing Projects:

- E-Rate project implementation
- Website Updates/ Maintenance
- Self-Check Machine replacements/ refresh
- Information Desk PC upgrades
- SirsiDynix contract extension/renewal
- Bookmobile Technology Equipment
- Online library card auto-processing
- On premise backup solution

#### Upcoming Projects:

- ILS RFP research
- Payment Terminal/ Cash register upgrades
- Workstation Windows 11 upgrade/replacement
- Office 2019/2016 End of life
- Meeting documents automation
- Library Public Education Channel 31 on Spectrum Cable
- Domain migration to ca.gov

#### System Updates:

Updated self-registration processes were not completed, so the new online system has been taken offline. The current manual process is still available for patrons.

Participated in 1 on 1 with Director and Assistant Director to discuss ongoing project, priorities, long-term vision. New projects have been added including on-site backups, windows 11 updates and upgrades, domain migration for website and email services, monitor upgrades for remaining old pcs, and

Maintenance updates for website, new website, mobile app, staff ipads, servers, user endpoints, and payment processing systems.

The IT consultant met with numerous third-party vendors to conduct research and provide input and consultation for special projects. These projects included ILS RFP, self-checkout machine upgrades, facility security, cash register/ e-commerce service providers, Cyber Security vendors, and others.





Page intentionally left blank

**PLACENTIA LIBRARY DISTRICT BOARD OF TRUSTEES**

**TO:** Jeanette Contreras, Library Director

**FROM:** Yesenia Baltierra, Assistant Library Director

**SUBJECT:** Customer Service Report for July 2024

**DATE:** August 26, 2024

<b>Attendance</b>	<b>July</b>	<b>July</b>	<b>FY-T-D</b>	<b>FY-T-D</b>	<b>FY-T-D</b>
	<b>2024</b>	<b>2023</b>	<b>2024-25</b>	<b>2023-24</b>	<b>% change</b>
Number of Days Open	30	30	30	30	2%
Number of Hours Open	271	264	271	264	3%
Attendance	22,556	17,688	22,556	17,688	28%

<b>Card Holders</b>	<b>July</b>	<b>July</b>	<b>FY-T-D</b>	<b>FY-T-D</b>	<b>FY-T-D</b>
	<b>2024</b>	<b>2023</b>	<b>2024-25</b>	<b>2023-24</b>	<b>% change</b>
Active Borrowers	6,268	5,883	6,268	5,883	7%
Child Card Holders	15,737	14,770	15,737	14,770	7%
Teen Card Holders	4,702	4,583	4,702	4,583	3%
Adult Card Holders	48,817	45,464	48,817	45,464	7%
<b>Total Card Holders</b>	<b>69,256</b>	<b>56,246</b>	<b>69,256</b>	<b>56,246</b>	<b>23%</b>
New Patron Registration	396	354	396	354	12%
New Virtual Library Cards	85	79	85	79	8%

<b>Information Desk Activity</b>	<b>July</b>	<b>July</b>	<b>FY-T-D</b>	<b>FY-T-D</b>	<b>FY-T-D</b>
	<b>2024</b>	<b>2023</b>	<b>2024-25</b>	<b>2023-24</b>	<b>% change</b>
Reference Questions -- in person	2,103	2,244	2,103	2,244	-6%
Reference Questions -- telephone	598	506	598	506	18%
Reference Questions -- email/chat	1	5	1	5	-80%
Total Reference Questions	2,702	2,755	2,702	2,755	-2%
Assistance in Spanish	51	73	51	73	-30%
Assistance with Passports	480	334	480	334	44%
Curbside Usage	1	13	1	13	-92%
Study Room Usage	226	171	226	171	32%

<b>Passport Activity</b>	<b>July</b>	<b>July</b>	<b>FY-T-D</b>	<b>FY-T-D</b>	<b>FY-T-D</b>
	<b>2024</b>	<b>2023</b>	<b>2024-25</b>	<b>2023-24</b>	<b>% change</b>
Passports Processed	419	327	419	327	28%
Consultations Only	20	25	20	25	-20%
Unfilled Appointments Sat-Sun	154	4	154	4	3750%
No Show Appointments Sat-Sun	32	14	32	14	129%
Total Photos walk in/application	282	212	282	212	33%

**ACTIVITIES**

- Angie processed 768 new books.
- Yomara mailed 56 billing notices.
- Meeting room was used by 2 library partners: PLFF and Kiwanis
- Meeting room was used by 1 outside renter: Broadmoor HOA
- Meeting Room was used 28 times for library related activities/programs.
- Staff filled 325 requests from the pull list.
- Staff pulled 106 expired holds from the request shelf.

**MEETINGS**

- Estella attended the SLS Meeting at Huntington Beach Library on July 18th. The consortium discussed the existing kiosks and the newly purchased ones from Huntington Beach. The staff also provided a tour of their new automated check-in system.

**PROFESSIONAL DEVELOPMENT**

- None

---

---

**PLACENTIA LIBRARY DISTRICT BOARD OF TRUSTEES**

---

---

**TO:** Library Board of Trustees

**FROM:** Jeanette Contreras, Library Director

**SUBJECT:** Authorize the Placentia Library District to Invest with the California Cooperative Liquid Assets Securities System (CLASS)

**DATE:** August 26, 2024

**BACKGROUND**

The main purpose of any investment policy is safety, liquidity, and return, in that order. As of July 2024, the District had \$852,276 invested in the Orange County Investment Pool (OCIP), and general fund (GF) bank savings of \$2,624,069 with a current yield percentage of 4.53 and 3.45, respectively. Additionally, the District's GF also includes a checking account of \$595,576 and \$173,060 for payroll, both with local bank institutions. These investments offer safety and liquidity, but returns could be improved by looking into other investment strategies.

Despite the anticipated federal tax rates decrease in September, it is prudent for the District to consider moving some of the funds into higher yield investments that can be accessed on a daily basis. Both OCIP and CLASS Prime Fund investments are a stable net asset valuation. The process to transfer money from the County pool to the District checking account takes an average of two weeks to complete, while the money market can be accessed quickly, usually within the same business day.

CLASS offer no fees, same day withdrawals, and feature safe investments which is the primary goal of an investment policy. Additionally, CLASS allows for multiple sub-accounts which would allow the District to have a separate account for general investments and an operating reserve (6 months of budgeted expenses).

As of July 2024, the Daily Effective Yield in the CLASS Prime Fund was 5.4348% while OCIP was 4.53% and fund savings was 3.45%. The Bank of Montreal (BMO) savings account current balance of \$3,498,209.20 includes earmarked grants and restricted library impact fees. The proposed action is consistent with policies adopted by the Board including the Investment of District Funds Policy 3035. Current CLASS clients include Altadena Library District, Palos Verdes Library District, Beaumont Library District, Banning Library District, Orange County Cemetery District, East Orange County Water District, City of Fullerton, City of Santa Ana, and 180 other government agencies.

Return on investment projects based \$2,624,068.52:

Investment Options	Monthly	Annual
CLASS (5.4348%)	\$11,884.41	\$142,612.88
OCIP (4.53%)	\$9,905.86	\$118,870.30
BMO (3.45%)	\$7,544.20	\$90,530.36

A CLASS informational packet will be provided at the meeting. Ms. Crystal Lynn, CLASS Director of Investment Services will be available to answer questions from the Board.

Attachment A is CLASS Prime Investment calculator sheet.

**RECOMMENDATIONS**

1. Authorize District to withdraw \$2,624,068.52 from the BMO savings account and invest and enroll in the CLASS Prime Fund; and,
2. Authorize the Library Director to complete and execute documents as needed.

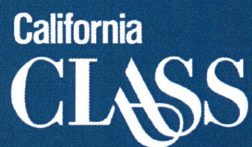

## Invest with California CLASS Prime

Investing with California CLASS Prime could mean more for your local community.  
Use the California CLASS Prime investment calculator to see just how much you could have earned.

**Amount Invested**

\$1,000,000

**Start Date**

July 1, 2024

**End Date**

July 31, 2024

You would have earned

**\$4,591.32**

on your investment if you started on

**July 1, 2024**

**California CLASS Prime Investment Income Earned**

As of Date	Time	\$1M	\$5M	\$10M
Jul 01 - Jul 31	1 month	\$4,591	\$22,957	\$45,913
Feb 01 - Jul 31	6 months	\$27,221	\$136,104	\$272,207
Aug 01 - Jul 31	12 months	\$56,039	\$280,195	\$560,389

Months listed are in the years 2023-2024

California CLASS Prime Daily Yields as of Month-End

Month	Year	Month-End Yield
July	2024	5.4348%
June	2024	5.4111%
May	2024	5.4134%
April	2024	5.3199%
March	2024	5.4330%
February	2024	5.4375%
January	2024	5.4710%
December	2023	5.5508%
November	2023	5.5691%
October	2023	5.5540%
September	2023	5.5193%
August	2023	5.4663%

For more information on both historical yields and annualized performance, visit [www.californiaclass.com/rates](http://www.californiaclass.com/rates) or scan the below QR code:

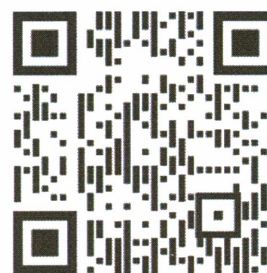

Source: Public Trust Advisors, LLC. Data unaudited. Charts and/or values presented may not add up precisely to absolute figures due to rounding. Investment income earned values shown may reflect immaterial variance from exact statement balances due to rounding. Performance results are shown net of all fees and expenses and reflect the reinvestment of dividends and other earnings. Many factors affect performance including changes in market conditions and interest rates and in response to other economic, political, or financial developments. Investment involves risk including the possible loss of principal. No assurance can be given that the performance objectives of a given strategy will be achieved. California CLASS Prime is not a bank. An investment in California CLASS Prime is not insured or guaranteed by the Federal Deposit Insurance Corporation or any other government agency. Although the California CLASS Prime stable NAV fund(s) seek to preserve the value of your investment at \$1.00 per share, California CLASS Prime cannot guarantee they will do so. Please review the applicable Information Statement(s) before investing. **Past performance is no guarantee of future results. Any financial and/or investment decision may incur losses.**



Page intentionally left blank



---

---

**PLACENTIA LIBRARY DISTRICT BOARD OF TRUSTEES**

---

---

**TO:** Library Board of Trustees

**FROM:** Carlo Maskarino, Business Manager

**SUBJECT:** **Review and Approve the Request for Proposal for General Contractors to Construct Loading Dock and Outdoor Library Space**

**DATE:** August 26, 2024

**BACKGROUND**

The purpose of this report is to request approval to issue a Request for Proposal (RFP) for construction services related to the Outdoor Learning Experience (OLE) project. The RFP will seek qualified contractors to provide construction services that meet the specifications and requirements of the project.

As part of our ongoing efforts to enhance the services and spaces of our community's gem, we are creating a dedicated outdoor space that will be accessible to all our patrons. The new butterfly garden themed area will offer a serene and welcoming environment for reading, studying, and community activities. The expanded 6,600 square foot outdoor footprint will feature comfortable seating, shaded areas, beautifully landscaped surroundings, and wi-fi access, -- enabling patrons to stay connected with free high-speed internet throughout the outdoor area. We envision this space as a hub for outdoor reading programs, storytimes, book clubs, and other library events.

The benefits of outdoor spaces in libraries are numerous. They provide a peaceful setting that encourages relaxation and creativity, support mental and physical well-being, and offer an inclusive environment that can be enjoyed by everyone. Our new outdoor space will be designed to accommodate individuals of all ages and abilities, ensuring that it is a truly inclusive addition to our library. Example of OLE services and activities include Wifi, Food Distribution, Storytime, Community Meetings, Cultural Movie Night, Outdoor Art, Adult Health & Wellness Classes, and Tutoring.

The project will involve new construction and demolition for a 6,600 square foot area. The scope of work (SOW) includes:

- **Survey and Assessment:** Conduct a site survey to assess current conditions, including grading, drainage, and any existing utilities.
- **Clearing and Grading:** Clear the designated area of any debris, vegetation, or obstacles. Grade the site as necessary to ensure proper drainage and foundation stability.

- **Utility Coordination:** Identify and mark any underground utilities. Coordinate with relevant authorities if relocation or protection of utilities is required.
- **Foundation Work:** Install necessary foundations for any permanent structures, including footings for pergolas, seating, or shade structures.
- **Paving and Pathways:** Construct pathways using concrete or acceptable alternatives to create accessible routes throughout the outdoor space.
- **Seating and Structures:** Install seating options such as benches, tables, and chairs. Construct any additional structures such as pergolas, gazebos, or shade sails.
- **Landscaping:** Integrate landscaping elements, including planting beds, trees, shrubs, and ground cover. Ensure that plant selections are suitable for the local climate and require minimal maintenance.
- **Lighting and Electrical:** Install outdoor lighting fixtures to ensure safety and usability of the space during evening hours. Provide electrical outlets for use during outdoor events.
- **Finishing Touches:** Apply finishing touches such as paint, sealant, and any other protective coatings to all surfaces as needed.
- **Clean-Up:** Remove all construction debris and perform a final site clean-up to ensure the space is ready for public use.
- **Inspection and Approval:** Coordinate a final inspection with library representatives to ensure all work meets the required standards and specifications. Address any punch list items as identified during the inspection.

To move forward with the OLE project, it is necessary to engage a qualified contractor through a competitive bidding process. The RFP will be structured to ensure that potential contractors have the necessary qualifications, experience, and capacity to complete the project on time and within budget.

The RFP will include the following key components:

- **Project Scope:** Detailed description of the construction services required, including specific tasks, deliverables, and timelines.
- **Qualification Requirements:** Criteria that contractors must meet, including previous experience with similar projects, licensing, and certifications.
- **Evaluation Criteria:** Proposals will be evaluated based on factors such as cost, experience, timeline, and the quality of past work. Weight will be given to proposals that demonstrate innovation, efficiency, and a strong understanding of the project's goals.
- **Bid Submission Requirements:** Guidelines for submitting bids, including required documentation, format, and deadlines.
- **Timeline:** The RFP will be issued on August 27, 2024 with proposals due by September 17, 2024. Construction to begin October 1, 2024.

The estimated budget for the construction services is \$967,000. Funding for this project will come from a grant from Assemblyman Phillip Chen's Office, library impact fees, and reserves.

Attachment A is the draft of the RFP for general contracting services for the loading dock and outdoor library projects.

Attachment B is the plan documents.

**RECOMMENDATIONS**

1. Discuss the proposed RFP as presented with inclusion of input from the Library Board of Trustees; and,
2. Authorize the issuance of the RFP for construction services for the OLE project.

**PLACENTIA LIBRARY DISTRICT  
REQUEST FOR PROPOSAL (RFP)  
GENERAL CONTRACTING SERVICES  
RFP NO.: 2024-02**



**PLACENTIA LIBRARY DISTRICT  
411 E. Chapman Ave.  
Placentia, CA 92870**

**Carlo Maskarino  
Business Manager  
(714) 528-1906 Ext. 216  
cmaskarino@placentialibrary.org**

Approved for Release:

---

Jeanette Contreras  
Library Director  
Placentia Library District

**Mission Statement:** Placentia Library District inspires, opens minds, innovates, and connects our community

**District Goals:**

- Strengthen connections and expand community relationships.
- Provide equitable access.
- Adapt to community needs.
- Cultivate thriving collections of resources.
- Provide and promote relevant library services.
- Maintain fiscal responsibility and integrity.
- Support and empower staff.
- Provide an inviting, pleasant, and safe place to explore.

**INTRODUCTION**

The Placentia Library District (“District”) hereby requests bids from qualified contractors for the construction of an OUTDOOR LIBRARY ADDITION and DOCK MODIFICATIONS. The successful Bidder shall have the knowledge, expertise, staff resources, licenses and availability to provide construction services for a new outdoor patio area, which includes site clearing / demo, concrete footings, acrylic perimeter wall, site concrete, decorative concrete, landscaping, shade structure, site furniture, lighting throughout site / shade structure, book drop, and EV charging station. In addition, modifications will be made to the loading ramp, handrail, sidewalk, and curbs.

**DISTRICT OVERVIEW**

Primarily known as a bedroom community, the City of Placentia, which is nestled in northern Orange County, is a family-oriented community of approximately 51,000 residents. Placentia serves an area of approximately 6.7 square miles and has retained the small-town image that has remained since settlers arrived more than 100 years ago.

The Placentia Library District is an independent special district serving the residents of Placentia and surrounding communities. It is governed by a board of five trustees directly elected by the public. The district has been serving the community since 1919 and now provides a variety of services including a large physical and digital catalog, virtual and in-person library programs, literacy services, gathering space, public computer stations, passport processing, a library of things (LOTs), and learning opportunities.

The District is open seven days a week – Monday through Thursday, 9:00 a.m. – 8:00 p.m.; Friday and Saturday, 9:00 a.m. – 5:00 p.m.; Sunday 1:00 p.m. – 5:00 p.m.

**RFP BID PACKAGE**

- RFP
- Appendix A Contractor Application Form
- Appendix B Example Consultant Agreement Form
- Plan Documents of Outdoor Library and Loading Dock

## **SCOPE OF WORK**

The District is soliciting bids from qualified professional contractors to perform the following, but not limited to, scopes of work below:

### Outdoor Library

The outdoor library portion of the scope consists of an addition of 6,596 SF outdoor library of building area to the existing library. It includes removal of existing landscape and addition of exterior enclosed reading garden space with structural shading and natural shading elements. The reading garden space includes digital connectivity, landscaping, automatic irrigation system, security walls and furniture. Some additional work includes the following:

#### Site Clearing and Demolition

- Saw cut, remove and haul approximately 175 SF of existing asphalt pavement and base per the Outdoor Library plans.
- Remove and dispose of approximately 100 LF of existing concrete curb per the Outdoor Library plans.
- Saw cut, remove and haul approximately 340 SF of existing concrete sidewalk per the Outdoor Library plans.
- Cap and / or remove and dispose of up to 605 LF of existing irrigation as necessary within the project area per the Outdoor Library plans.
- Remove approximately 6,365 SF of existing landscape and vegetation per the Outdoor Library plans.
- Removal and disposal of 2 pine trees per the Outdoor Library plans.
- Removal of old library book drop

#### Site Concrete and Paving

- Construct approximately 445 SF of decorative concrete per the Outdoor Library plans.
- Construct approximately 1,730 SF of flagstone paving per the Outdoor Library plans.
- Install approximately 255 SF of 4" concrete sidewalk per the Outdoor Library plans.
- Construct approximately 335 SF of full depth asphalt per the Outdoor Library plans.

#### Patio Shade Structure

- The 54'-0" x 23'-4" shade structure will be furnished by the Placentia Library District.
- The shade structure will be installed by the Contractor and all footings / foundations required to do so.

#### Acrylic Decorative Panel Fence

- Construct approximately 225 LF of decorative panel fence / privacy wall per the Outdoor Library plans.

#### Site Furniture

- The contractor will be required to provide and install several chairs and benches throughout the patio per the Outdoor Library Patio plans.
- The contractor will be required to provide and install outdoor butterfly decor throughout the patio per the Outdoor Library Patio plans.

#### EV Charging Station

- The contractor will be required to provide and install EV charging stations.

#### Book Drop

- The contractor will be required to provide and install new library book drop.

#### Loading Dock Ramp Expansion

The Loading Dock portion of the work consists of demolition, disposal, and construction of sidewalk, curbs, loading ramp, and handrails inclusive of the following:

#### Ramp

- Saw cut, remove and haul approximately 160 SF of asphalt per Loading Dock Ramp Expansion plans.
- Replace approximately 100 SF of asphalt per Loading Dock Ramp Expansion plans.
- Remove approximately 10 LF of existing steel post, chain link and all related work at existing dock and replace per Loading Dock Ramp Expansion plans.

#### Handrail

- Furnish and install approximately 48 LF of new handrail on the new ramp per Dock Ramp Expansion plans.

#### Sidewalk

- Remove approximately 48 LF of existing steel post, chain link and all related work at existing sidewalk to dock per Loading Dock Ramp Expansion plans.
- Construct approximately 48 LF of existing steel post, chain link and all related work at existing sidewalk to dock per Loading Dock Ramp Expansion plans.

#### Curbs

- Construct approximately 50 LF of curb and extended sidewalk per Dock Ramp Expansion plans

#### Other

- Operate and leave work area at end of day free from obstruction.
- Bid must include obtaining city permits, plan checks, licenses, plans, and the like. Placentia Library District will pay for permitting, but it is the Contractor's responsibility to pull permits.

- ADA improvements/alterations where applicable must be included in bid.
- Job must be priced for prevailing wage.
- Before mobilization Dig-Alert must be contacted and follow instructions as provided by Dig-Alert.

### **BID FORMAT GUIDELINES**

Respondents to this RFP must comply with the following bid submission requirements:

Provide one (1) unbound copy, five (5) bound copies, a sealed fee proposal, and one (1) electronic copy of the Submittal.

- The electronic copy will only be accepted via email in the following programs: Microsoft Office Suite or PDF.
- Electronic copy shall be emailed to [administration@placentialibrary.org](mailto:administration@placentialibrary.org) with appropriate subject line.
- Faxed Bids will not be received or considered.

*The Placentia Library District shall have no obligation and will not reimburse responding firms for any expenses incurred in preparing bids in response to this RFP.*

A. RECEIPT OF BIDS. Bids must be received no later than **5:00 p.m. (P.S.T) on Tuesday, September 17, 2024**, to the address below. Bids will not be accepted after this deadline. Bids shall be delivered to and marked as set forth below:

Placentia Library District  
Administration  
411 E. Chapman Avenue  
Placentia, CA 92870

#### RE: RFP OUTDOOR LIBRARY AND LOADING DOCK EXPANSION

B. OPENING OF BIDS AND AWARD OF CONTRACT. The Bids will be reviewed at on **Wednesday, September 18, 2024**, at the above-mentioned address of the District. The Contract may be awarded at the District's Board of Trustee's meeting as is scheduled for **6:30P.M. on Monday, September 23, 2024**.

C. DELIVERY OF BIDS. It is the responsibility of the bidder to see that any bid that is hand delivered, sent through the mail, or by any other delivery method, shall have sufficient time to be received by the Placentia Library District by the due date and time. Late bids will not be accepted.

D. LOCATION OF WORK. The work to be performed is located at the Placentia Library District, 411 E. Chapman Avenue, Placentia, CA 92870.

E. COMPLETION OF WORK. Time is of the essence. All WORK must be completed within 90 consecutive calendar days and initiated within 10 days of date stated in the Notice to Proceed.

F. DESCRIPTION OF WORK. The WORK includes, but not limited to, the Scope of Work as described above and throughout the contract plans.

G. OBTAINING CONTRACT DOCUMENTS. The successful Bidder will be required to enter into the District's standard public works contract.



H. BID SECURITY. Each Bid shall be accompanied by cash, a certified or cashier's check or Bid Bond in the amount of not less than 10 percent (10%) of the Total Bid Price payable to the Placentia Library District as a guarantee that the Bidder, if its Bid is accepted, will promptly obtain the required Bonds and Insurance and execute the Agreement. A Bid shall not be considered unless one of the forms of Bidder's security is enclosed with the Bid. If the Bidder to whom the WORK has been awarded and to whom the request has been made refuses or fails to enter into said contract and provide the required bonds within the specified time, the check shall be forfeited to the District for the principal and surety on the bond shall be liable to the District for the principal amount thereof in accordance with its terms. If the bidder that provides the most value to the District is not accepted by the District within the time specified under "Award of Contract," or for such further period of time as may be agreed upon in writing between the District and the Bidder concerned, or if the Bidder to whom the contract is awarded executes and delivers to the District the required contract documents, the amount of the certified or cashier's check will be returned to the Bidder. Attention is directed to the requirement noted on contract bonds that the Attorney-in-Fact attach a certified copy of the Power of Attorney. If the Bidder elects to furnish a bid bond as the Bidder's bid security, the Bidder shall use the bid bond form bound herein, or one conforming substantially to it in form and acceptable to the District.

J. AWARD OF CONTRACT. The contract will be awarded to the bidder that brings the most value to the District. The District, however, reserves the right, after opening, to reject any and all bids, or to waive any minor informality in a bid.

K. PERFORMANCE AND PAYMENT BONDS. The successful bidder will be required to furnish, prior to award of the Contract, a Performance Bond in the amount of one hundred percent (100%) of the Total Bid Price, and a Payment (Material and Labor) Bond in the amount of one hundred percent (100%) of the Total Bid Price.

L. CONTRACTOR'S LICENSE CLASSIFICATION. Subcontractors must possess the appropriate licenses for each specialty subcontracted. The Bidder, in its bid, shall disclose its license type, number, and expiration date. Failure to provide the specified license shall render the Bid as non-responsive and shall act as a bar to award of the Contract to such Bidder.

M. REFERENCE FOR MATERIAL. In accordance with § 3400 of the California Public Contract Code, the Bidder will be provided a period of not less than 35 days after award of the contract for submission of data substantiating a request for an "or equal".

N. BIDS TO REMAIN OPEN. The Bidder shall guarantee the Total Bid Price for a period of 90 calendar days from the date of bid opening.

O. CALIFORNIA WAGE RATE REQUIREMENTS. The District has been advised by the State of California Director of Industrial Relations of its determination of the general prevailing rate of per diem wages and the general prevailing rate for legal holiday and overtime work in the locality in which the WORK is to be performed for each craft or type of work needed to execute the Contract ("General Prevailing Wage Rates"). It shall be mandatory upon the CONTRACTOR to whom the WORK is awarded and upon any subcontractor under the CONTRACTOR to pay not less than said specified rates to all workmen employed by them in the execution of the WORK. All Bidders shall take notice of the following requirements and notices pursuant to the California Labor Code:

- No contractor or subcontractor may be listed on a bid proposal for a public works project unless registered with the Department of Industrial Relations pursuant to Labor Code section 1725.5 [with limited exceptions from this requirement for bid purposes only under Labor Code section 1771.1(a)].
- No contractor or subcontractor may be awarded a contract for public work on a public works project unless registered with the Department of Industrial Relations pursuant to Labor Code section 1725.5. The Bidder shall submit proof of public works contractor registration or qualification for an exemption at the time the bid is submitted. The District will not accept a bid in which the Bidder as the contractor or any listed subcontractors are not registered in accordance with Labor Code Sections 1725.5 and 1771.1.
- The wages set forth as the General Prevailing Wage Rates for this project will be posted at the job site. It is the responsibility of the CONTRACTOR to determine the correct scale.
- This project is subject to compliance monitoring and enforcement by the Department of Industrial Relations.

P. SECURITY SUBSTITUTIONS FOR MONEYS WITHHELD TO ENSURE BIDDER'S PERFORMANCE. In accordance with Section 22300 of the State of California Public Contract Code, the Contractor at his request and expense, will be permitted to substitute equivalent securities for any monies withheld to ensure performance. Refer to applicable portions of and the Escrow Agreement for Security Deposits in Lieu of Performance Retentions included with the Contract Documents. Earnings will not be retained.

Q. RESERVED. WARRANTY: Minimum of 1 year for parts, 1 year for labor and workmanship, or referenced in the contract documents, whichever is in favor of the Placentia Library District.

R. PROJECT ADMINISTRATION. All communications relative to this WORK, including any request for a pre-bid site visit shall be directed to the District prior to opening of the Bids at the following.

Placentia Library District  
411 E. Chapman Ave.  
Placentia, CA 92870  
Telephone: (714) 528-1906 x216  
Email: [cmaskarino@placentialibrary.org](mailto:cmaskarino@placentialibrary.org)  
Attention: Carlo Maskarino, Business Manager

S. DISTRICT'S RIGHTS RESERVED. The District reserves the right to reject any or all bids, to waive any informality in a bid, and to make awards to the lowest responsive, responsible bidder as it may best serve the interest of the District.

T. LIQUIDATED DAMAGES. Failure of the Contractor to complete the work within the time allowed will result in damages being sustained by the Library District. Such damages are, and will continue to be, impracticable and difficult to determine. For each day in excess of the time specified for completion of the work (as adjusted by any Change Orders), the Contractor shall be liable to the City for the sum stated as liquidated damages below.

Failure to comply with these provisions will result in assessment of Liquidated Damages in the amount of \$1,500.00 per day. The Library District will deduct the total amount of these Liquidated Damages from the Contractor's final progress payment or project retention monies without further notification to the Contractor.

U. MONTHLY PAYMENT APPLICATIONS. On the workday following the designated closure date for preparation of progress estimates, the Contractor shall submit to the Construction Manager a written progress estimate based on the contract unit prices or the work that has been satisfactorily completed. The

Construction Manager will review the estimate and approve it or notify the Contractor of any exceptions. The Construction Manager will determine and prepare the partial and final payments. If the Contractor fails to submit a written progress estimate, the Construction Manager will determine the quantity of work performed. No such progress estimate will be required, nor payment be made when the total number of working days is twenty-five (25) or less or when the value of the work totals less than \$500.00. Progress payment will, when properly completed as specified, be paid within thirty (30) calendar days of submittal, and it is understood that any delay in the preparation, approval and payment of these demands will not constitute a breach of contract on the City.

V. AS-BUILT DRAWINGS. The Contractor shall maintain a "Record" set of Drawings and Specifications on the job site at all times, including all executed addenda, change orders, and field orders. This set of "Record Drawings" shall be separate, clean, blueline prints reserved for the purpose of showing a complete picture of the work actually constructed. These drawings shall be kept current with the construction and for the purpose of attaining a correct set of As-Built plans. All final locations determined in the field and any deviations from the Plans and Specifications shall be marked in red on this "Record" set of plans to show the As-Built conditions. Upon completion of all work, and before final payment, these "Record" drawings with all applicable As-Built notes shall be signed by the Contractor, dated, and returned to the Engineer for review and acceptance. Reviewed and accepted "Record" drawings are a condition for final acceptance. Progress payments may be withheld pending the receipt and approval of any outstanding As-builts.

W. CHANGE ORDERS. Agreement on any Change Order or Written Amendment to Contract shall be a full compromise and settlement of all adjustments to Contract Time and Contract Sum, and compensation for any and all delay, extended or additional field and home office overhead, disruption, acceleration, inefficiencies, lost labor or equipment productivity, differing site conditions, construction interferences and other extraordinary or consequential damages (hereinafter called "Impacts"), including any ripple or cumulative effect of said Impacts on the overall Work under the Contract arising directly or indirectly from the performance of Work described in the Change Order or Written Amendment to Contract. By execution of any Change Order or Written Amendment to Contract, Contractor agrees that the Change Order or Written Amendment to Contract constitutes a complete accord and satisfaction with respect to all claims for schedule extension, Impacts, or any costs of whatsoever nature, character or kind arising out of or incidental to the Change Order or Written Amendment to Contract. No action, conduct, omission, product failure or course of dealing by the Library District shall act to waive, modify, change, or alter the requirement that (i) Change Orders, Construction Change Directive, or Written Amendment to Contract must be in writing, signed by the Library District and Contractor and; (ii) that such written Change Orders,

Construction Change Directives, or Written Amendment to Contract are the exclusive method for effectuating any change to the Contract Sum and/or Contract Time.

The cost or credit to the Library District resulting from a change in the Work shall be determined by Library District by one or more of the following methods:

1. Mutual acceptance of a lump sum properly itemized and supported by sufficient substantiating data to permit evaluation;
2. Unit prices stated in the Contract Documents or subsequently agreed upon;
3. By cost, as defined in (a), (b), (c) and (d) below, properly itemized and supported by sufficient substantiating data to permit evaluation, plus agreed to markup for overhead and profit as defined in (e) below. Such costs shall be itemized by craft directly allocable to the change in the Work:
  - a) Cost of materials, including cost of transportation and delivery;
  - b) Cost of labor, including social security, and unemployment insurance, and fringe benefits required by agreement and Workers' Compensation insurance;

- c) Rental value of equipment and machinery, exclusive of hand tools;
- d) Sales tax; insurance; permit costs and bond premiums;
- e) Mark-up to Contractor, Subcontractors, and Sub-subcontractor for overhead, profit and other expenses which are not specifically included in (a) through (d) above shall not exceed the following amounts:
  - i. Fifteen (15%) of the cost of that portion of the Extra Work to be performed by the Contractor with its own forces.
  - ii. Fifteen percent (15%) of the cost of that portion of the Work to be performed by a Subcontractor or Sub-subcontractor with its own forces, plus 5% for the Contractor. Total combined Contractor, Subcontractor, and Sub-subcontractor fee shall not exceed 20%.
- f) Cost of Extra Work shall not include any of the following:
  - i. Superintendent(s)
  - ii. Assistant Superintendent(s)
  - iii. Project Engineer(s)
  - iv. Project Manager(s)
  - v. Scheduler(s)
  - vi. Estimator(s)
  - vii. Incidental Drafting or Detailing
  - viii. Small tools (Replacement value does not exceed \$300)
  - ix. Office expenses including staff, materials and supplies
  - x. On-Site or off-site trailer and storage rental and expenses

X. MONTHLY SCHEDULE UPDATES. Unless otherwise provided in the Agreement or Technical Specifications, the Project Schedule shall be in a detailed precedence CPM or Microsoft type format satisfactory to the Library District, which shall also: (i) provide a graphic representation of all activities and events that will occur during performance of the Work; (ii) identify each phase of construction and maintenance; and (iii) set forth dates that are critical in ensuring the timely and orderly completion of the Work in accordance with the requirements of the Contract Documents (hereinafter referred to as Milestone Dates). At a minimum the Project Schedule shall depict the schedule for Work on a discipline by discipline and trade by trade basis and tasks within each discipline and trade. The Project Schedule shall include: (i) proposed activity sequences and durations; (ii) Milestone Dates for receipt and approval of pertinent information, including Library District-supplied information and approvals by public authorities having jurisdiction over the Project; (iii) dates for preparation and processing of Shop Drawings, Product Data, and Samples; (iv) dates for delivery of materials or equipment requiring long-lead time procurement; (v) Library District's occupancy/use requirements showing portions of the Project having occupancy priority; (vi) the estimated date of Substantial Completion and Final Completion; and (vii) other information reasonably required by the Library District. Upon review and acceptance by the Library District of the baseline Project Schedule, the baseline Project Schedule shall be deemed part of the Contract Documents. If not accepted, the baseline Project Schedule shall be promptly revised by the Contractor in accordance with the recommendations of the Library District and re-submitted for acceptance.

- 1) Updates. With each Application for Payment submitted by Contractor (other than the Final Application for Payment), the Contractor shall submit to the Library District an updated Project Schedule revised to include, at a minimum:
  - a) Monthly update/status of electronic database shall include recording of all Actual Start Dates and Actual Finish Dates and status of activities in progress.
  - b) Review of "planned" versus "actual" work force allocations and progress for the preceding month.

- c) Reviews of revisions, added or deleted work and how those activities are being integrated into the Contractor’s work plan.
- d) Review of the Contractor’s interface and coordination with other work on the Project.
- e) Review of all impacts to the Work during the preceding month and to date, Contractor evaluation of those impacts and any recovery plans or remedial actions required to comply with the contract schedule.

If the Contractor does not submit an updated Project Schedule with an Application for Payment, the Library District may withhold payment, in whole or in part. In the event any update to the Project Schedule indicates any delays to the Contract Time that are the fault of Contractor or others for whom Contractor is responsible, the Contractor shall propose an affirmative plan to correct the delay, including overtime and/or additional labor, if necessary. In no event shall any Project Schedule Update constitute an adjustment in the Contract Time, any deadline, or the Contract Sum unless any such adjustment is agreed to by the Library District and authorized pursuant to Change Order, Construction Change Directive, or Written Amendment to Contract.

Y. WEEKLY COORDINATION / SITE MEETINGS. Construction meetings shall be held at the jobsite as scheduled by the Library District’s Project Manager or as requested by the Contractor. 3-Week Look Ahead schedules shall be provided by the Contractor prior to the Weekly Coordination Meetings to be reviewed at each meeting. They will show the previous 1-week of completed activities, as well as an additional 3-week look ahead of upcoming activities.

**Minimum Qualifications**

The information requested in this section should describe the qualifications of the firm or entity, including similar services within the past five years that are similar in size and scope to demonstrate competence to perform these services. Information shall include:

- Names of key staff that participated on named projects and their specific responsibilities with respect to RFP, Contract Amount, Type of work, Client, Date Completed, and Percent Subcontracted.
- A summary of your firm’s or entity’s demonstrated capability, including length of time that your firm has provided the Work being requested in this Request for Bids.
- List of Sub-Contractors: Name Under Which Subcontractor is Licensed, License No, Address of Office, Mail or Shop, Percent of Total Contract, Specific Description of Subcontracting.
- Bid Schedule inclusive of: Item No, Estimated Quantity, Unit, Description Written in Words, Unit Price, Amount.

Proposers shall provide at least three references that have received similar installations from your firm. The District reserves the right to contact any of the organizations or individuals listed. Information provided shall include:

- Client Name
- Project Description
- Project start and end dates
- Client project manager name, telephone number, and e-mail address

**SCHEDULE (SUBJECT TO CHANGE AS REQUIRED)**

Release of Request for Proposal	<b>Tuesday, August 27, 2024</b>
---------------------------------	---------------------------------

Deadline for Written Questions	<b>Tuesday, September 10, 2024</b>
Bids Due	<b>Tuesday, September 17, 2024</b>
Proposal Unsealed, Reviewed and Evaluated	<b>Wednesday, September 18, 2024</b>
Board of Trustees Consideration of Recommendation	<b>Monday, September 23, 2024</b>
Staff & Consultant Engagement for Transition Period	<b>Tentative Wednesday, September 25, 2024</b>
Contract Scheduled to Begin	<b>Tentative Tuesday, October 1, 2024</b>

**Questions**

Questions about this RFP must be directed in writing, via email to Administration at [administration@placentialibrary.org](mailto:administration@placentialibrary.org) and [cmaskarino@placentialibrary.org](mailto:cmaskarino@placentialibrary.org), on or before **Tuesday, September 10, 2024 at 5:00 p.m.** The District reserves the right to amend or supplement this RFP prior to the proposal due date. All amendments, responses to questions received, and additional information will be posted to the Placentia Library District official website, [www.placentialibrary.org](http://www.placentialibrary.org), under “Request for Bids” and other sites where the RFP is posted. Proposers should check this webpage daily for new information. The District will endeavor to answer all written questions in a timely order. The District reserves the right not to answer all questions. No questions other than written will be accepted, and no response other than written will be binding upon the District.

I have reviewed this RFP and acknowledged its contents and in submitting a bid, I understand the requirements for such submission and the scope of the work that is required to be performed.

Dated: \_\_\_\_\_, 2024                      By: \_\_\_\_\_  
Name: \_\_\_\_\_  
Title: \_\_\_\_\_

**APPENDIX A**

**REQUEST FOR BIDS  
OUTDOOR LIBRARY PATIO & LOADING DOCK EXPANSION  
Contractor Application Form**

Legal Contractual Name: \_\_\_\_\_

Contact Person for Agreement: \_\_\_\_\_

Corporate Mailing Address: \_\_\_\_\_

City: \_\_\_\_\_ State: \_\_\_\_\_ Zip Code: \_\_\_\_\_

E-Mail Address: \_\_\_\_\_

Phone: \_\_\_\_\_ Fax: \_\_\_\_\_

Contact Person for Bids: \_\_\_\_\_

Title: \_\_\_\_\_

E-Mail Address: \_\_\_\_\_

Business Telephone: \_\_\_\_\_

Business Fax: \_\_\_\_\_

Website: \_\_\_\_\_

Is your business: (check one)

- CORPORATION
- LIMITED LIABILITY PARTNERSHIP
- INDIVIDUAL
- SOLE PROPRIETORSHIP
- PARTNERSHIP
- UNINCORPORATED ASSOCIATION

Federal Tax Identification Number: \_\_\_\_\_

City of Placentia Business License Number: \_\_\_\_\_

Expiration Date: \_\_\_\_\_

(If none, you must obtain a Placentia Business License prior to performance of the contract.)

Contractor's License Number: \_\_\_\_\_

APPENDIX "B"

CONSULTANT AGREEMENT FOR GENERAL CONTRACTING SERVICES

This Consultant Agreement for General Contracting Services ("Agreement") is made and entered into as of the \_\_\_\_ day of \_\_\_\_\_, 202\_\_ by and between **Placentia Library District** ("District") and [**Name of Company**] ("Consultant" or "CONSULTANT"), (together, "Parties").

WHEREAS, Government Code section 4526, authorizes District to contract with and employ any person(s) for the furnishing of construction project management services on the basis of demonstrated competence and on the professional qualifications necessary for the satisfactory performance of the services required; and

WHEREAS, District duly determined that it needs some or all of the services (collectively, "Services") to be provided pursuant to this Agreement; and

WHEREAS, Consultant is specially trained, experienced, and competent to perform the Services required by District, as needed on the basis set forth in this Agreement.

NOW, THEREFORE, the Parties agree as follows:

1. **Services.** Consultant shall provide general contracting services as further described in RFP attached hereto and incorporated herein by this reference ("Services") and in accordance with District's request for proposals number 2024-02 (the "RFP") and Consultant's response thereto dated (insert date) (the "Proposal"), which are incorporated herein by this reference.
2. **Term.** Consultant shall commence providing services under this Agreement on \_\_\_\_\_, 202\_\_ and will diligently perform as required until project construction is completed.
3. **Submittal of Documents.** Consultant shall not commence the Services under this Agreement until Consultant has submitted and District has approved the documents, certificate(s) and affidavit(s), and endorsement(s) of insurance required as indicated below:

- \_\_\_\_\_ Signed Agreement
- \_\_\_\_\_ Workers' Compensation Certification
- \_\_\_\_\_ Insurance Certificates and Endorsements
- \_\_\_\_\_ W-9 Form
- \_\_\_\_\_ Other: \_\_\_\_\_

4. **Compensation.** District agrees to pay Consultant for services satisfactorily rendered pursuant to this Agreement a total fee not to exceed [**WORDS**] and **00/100 Dollars (\$XXXXX.00)**. District shall pay Consultant according to the following terms and conditions:

4.1. Payment for the Services shall be made for all undisputed amounts based upon the delivery of the work product as determined by District. Payment shall be made within thirty (30) days after Consultant submits an invoice to District for Services actually completed and after District's written approval of the Services, or the portion of the Services for which payment is to be made.



4.2. The Services shall be performed at the hourly billing rates and/or unit prices included in **Appendix “C.”** If hourly billing applies, the itemized invoice shall reflect the hours spent by Consultant in performing its Services pursuant to this Agreement.

4.3. Invoicing will be separated by project, “loading dock” and “outdoor library.” Within the loading dock project, the cost associated with the ramp and railing portion will be invoiced separately for grant-funded related purposes.

4.4. District may withhold or deduct from amounts otherwise due CONSULTANT hereunder if CONSULTANT fails to timely and completely perform material obligations to be performed on its part under this Agreement, with the amounts withheld or deducted being released after CONSULTANT has fully cured such failure of performance, less costs, damages or losses sustained by District resulting therefrom.

5. **Prevailing Wage.** Consultant is aware of the requirements of California Labor Code Section 1720, et seq., and 1770, et seq., as well as California Code of Regulations, Title 8, Section 16000, et seq., (“Prevailing Wage Laws”), which require the payment of prevailing wage rates and the performance of other requirements on “public works” and “maintenance” projects. If the services being performed are part of an applicable “public works” or “maintenance” project, as defined by the Prevailing Wage Laws, and the total compensation is \$1,000 or more, Consultant agrees to fully comply with such Prevailing Wage Laws to the extent applicable to performance of Consultant under this Agreement. Consultant shall defend, indemnify and hold the District, its elected officials, officers, employees and agents free and harmless from any claim or liability arising out of any failure or alleged failure to comply with the Prevailing Wage Laws.
6. **Materials.** Consultant shall furnish, at its own expense, all labor, materials, equipment, supplies and other items necessary to complete the services to be provided pursuant to this Agreement.
7. **Expenses.** District shall not be liable to Consultant for any costs or expenses paid or incurred by Consultant in performing services for District.
8. **Independent Contractor.** Consultant represents and warrants that Consultant is an independent contractor or business entity that is: (i) free from the control and direction of District in connection with the performance of the Services, (ii) performing Services that are outside the usual course of District’s business, and (iii) customarily engaged in an independently established trade, occupation, or business of the same nature as that involved in the Services performed, District being interested only in the results obtained. Consultant understands and agrees that it and all of its employees shall not be considered officers, employees, agents, partner, or joint venture of District, and are not entitled to benefits of any kind or nature normally provided employees of District and/or to which District’s employees are normally entitled, including, but not limited to, State Unemployment Compensation or Worker’s Compensation. Consultant shall assume full responsibility for payment of all federal, state and local taxes or contributions, including unemployment insurance, social security and income taxes with respect to Consultant’s employees.
9. **Performance of Consultant Services.**

9.1. **Standard of Care.** Consultant represents that Consultant has the qualifications and ability to perform the Services in a professional manner, without the advice, control or supervision of District. CONSULTANT, its officers, agents, employees, subcontractors, Consultants and any persons or entities for whom CONSULTANT is responsible, shall provide all Services pursuant to this Agreement in accordance with the requirements of this Agreement and in a manner consistent with the standard of care under California law applicable to those who specialize in providing the same services for projects of the type, scope, and complexity of the Project. District's review, approval of, or payment for any of the Services required under this Agreement shall not be construed as assent that CONSULTANT has complied, nor in any way relieve CONSULTANT of compliance, with (i) the applicable standard of care, or (ii) applicable statutes, regulations, rules, guidelines and requirements...

9.2. **Due Diligence.** Consultant will investigate District facilities and review written materials District makes available to Consultant to understand fully the nature and extent of the District's facilities and the Project(s). Consultant shall carefully study and compare all documents, findings, and other instructions and shall at once report to District, in writing, any error, inconsistency, or omission that Consultant or its employees may discover. Consultant shall have responsibility for discovery of errors, inconsistencies, or omissions.

9.3. **Meetings.** Consultant and District agree to participate in regular meetings on at least a weekly basis to discuss strategies, timetables, implementations of services, and any other issues deemed relevant to the operation of Consultant's performance of Services.

9.4. **Consultants as District Representative:** CONSULTANT will act as District's representative with the District's design firm and construction firm in rendering the Services and furnishing the work as described in RFP, commencing with the receipt of a written Notice to Proceed signed by District Representative.

9.5. **Coordination:** In the performance of CONSULTANT's services under this Agreement, CONSULTANT agrees that it will maintain coordination with District Project Manager as may be requested and desirable.

9.6. **District Approval.** The Services completed herein must meet the approval of District and shall be subject to District's general right of inspection and supervision to secure the satisfactory completion thereof.

10. **Originality of Services.** Except as to standard generic details, Consultant agrees that all technologies, formulae, procedures, processes, methods, writings, ideas, dialogue, compositions, recordings, teleplays and video productions prepared for, written for, or submitted to District and/or used in connection with this Agreement, shall be wholly original to Consultant and shall not be copied in whole or in part from any other source, except that submitted to Consultant by District as a basis for such services.

11. **Deliverables.** Consultant understands and agrees that all matters produced under this Agreement shall become the property of District and cannot be used without District's express written permission.

12. **Audit.** Consultant shall establish and maintain books, records, and systems of account, in accordance with generally accepted accounting principles, reflecting all business operations of Consultant transacted under this Agreement. Consultant shall retain these books, records, and systems of account during the Term of this Agreement and for five (5) years thereafter. Consultant shall permit District, its agent, other representatives, or an independent auditor to audit, examine, and make excerpts, copies, and transcripts from all books and records, and to make audit(s) of all billing statements, invoices, records, and other data related to the Services covered by this Agreement. Audit(s) may be performed at any time, provided that District shall give prior notice to Consultant and shall conduct audit(s) during Consultant's normal business hours, unless Consultant otherwise consents. CONSULTANT shall comply with these provisions within fifteen (15) days of District's written request to review and audit any or all of CONSULTANT's Project-related records and information.

13. **Disputes.**

13.1. In the event of a dispute between the parties as to performance of the Services, the interpretation of this Agreement, or payment or nonpayment for work performed or not performed, the parties shall attempt to resolve the dispute in good faith. Pending resolution of the dispute, Consultant agrees it will neither rescind the Agreement nor stop the performance of the Services, but will allow determination by the court of the State of California, in the county in which District's administration office is located, having competent jurisdiction of the dispute. Disputes may be determined by mediation if mutually agreeable, otherwise by litigation. Notice of the demand for mediation of a dispute shall be filed in writing with the other party to the Agreement. The demand for mediation shall be made within a reasonable time after written notice of the dispute has been provided to the other party, but in no case longer than ninety (90) days after initial written notice.

14. **Termination.**

14.1. **For Convenience by District.** District may, at any time, with or without reason, terminate this Agreement and compensate Consultant only for services satisfactorily rendered to the date of termination. Written notice by District shall be sufficient to stop further performance of Consultant's Services. Notice shall be deemed given when received by Consultant or no later than three (3) days after the day of mailing, whichever is sooner.

14.2. **With Cause by District.** If CONSULTANT fails to perform CONSULTANT's duties to District's satisfaction, or if CONSULTANT fails to fulfill in a timely and professional manner CONSULTANT's material obligations under this Agreement, or if CONSULTANT violates any of the material terms or provisions of this Agreement, District shall have the right to terminate this Agreement for cause effective immediately upon District giving CONSULTANT written notice thereof. Cause shall include, but not limited to:

14.2.1. Consultant's material violation of this Agreement; or

14.2.2. any Consultant act exposing District to liability to others for personal injury or property damage; or

14.2.3. Consultant is adjudged a bankrupt, Consultant makes a general assignment for the benefit of creditors, or a receiver is appointed on account of Consultant's insolvency.

Written notice by District shall contain the reasons for such intention to terminate. In the event of this termination, District may secure the required services from another Consultant and to the extent the expense, fees, and/or costs to District in doing so exceed the cost of providing the service pursuant to this Agreement, Consultant shall be liable to the District for such costs, in addition to any other damages the District may suffer due to Consultant's breach.

## **15. Indemnification.**

15.1. To the furthest extent permitted by California law, Consultant shall indemnify and hold harmless District, its Board of Trustees, agents, representatives, officers, consultants, employees, trustees, and volunteers (the "Indemnified Parties") from any and all claims, demands, causes of action, costs, expenses, liability, loss, damage or injury of any kind, in law or equity ("Claim") arising out of, pertaining to, or relating to the negligence, recklessness, or willful misconduct of Consultant, its officers, employees, subcontractors, consultants, or agents during the performance of this Agreement. Consultant shall also, to the furthest extent permitted by California law, defend the Indemnified Parties at Consultant's own expense, including attorneys' fees and costs, from any and all Claim(s) and allegations relating thereto. Should Consultant elect to defend the Indemnified Parties with a reservation of rights, District shall have the right to accept or reject any legal representation that Consultant proposes to defend the Indemnified Parties and to provide for its own defense. Consultant's obligations under this Article do not apply to Claims which arise out of the sole negligence or willful misconduct of the Indemnified Parties...

15.2. Consultant shall pay and satisfy any judgment, award, or decree that may be rendered against the Indemnified Parties in any Claim, subject to section 15.1 above. Consultant's obligation pursuant to this Article includes reimbursing the cost of any settlement paid by the Indemnified Parties and for any and all fees and costs, including but not limited to legal fees and costs, expert witness fees, and consultant fees, incurred by the Indemnified Parties in the defense of any Claim(s) and to enforce the indemnity herein, subject to section 15.1 above. Consultant's obligation to indemnify shall not be restricted to insurance proceeds.

15.3. District may withhold any and all costs that arise out of, pertain to, or relate to the negligence, recklessness, or willful misconduct of Consultant from amounts owing to Consultant.

## **16. Insurance.**

16.1. **Coverage.** Consultant shall procure and maintain at all times it performs any portion of the Services the following insurance with minimum limits equal to the amount indicated below.

Type of Coverage	Minimum Requirement
<b>Commercial General Liability Insurance</b> , including Bodily Injury, Personal Injury, Property Damage, Advertising Injury, and Medical Payments Each Occurrence General Aggregate	  \$ 1,000,000 \$ 2,000,000
<b>Automobile Liability Insurance - Any Auto</b> Each Occurrence General Aggregate	 \$ 1,000,000 \$ 2,000,000
<b>Professional Liability</b>	\$ 2,000,000
<b>Workers Compensation</b>	Statutory Limits
<b>Employer’s Liability</b>	\$ 1,000,000

16.1.1. **Commercial General Liability and Automobile Liability Insurance.** Commercial General Liability Insurance and Any Auto Automobile Liability Insurance that shall protect Consultant, District, and the State from all claims of bodily injury, property damage, personal injury, death, advertising injury, and medical payments arising performing any portion of the Services. (Form CG 0001 and CA 0001, or forms substantially similar, if approved by District.)

16.1.2. **Workers’ Compensation and Employer’s Liability Insurance.** Workers’ Compensation Insurance and Employer’s Liability Insurance for all of its employees performing any portion of the Services. In accordance with provisions of section 3700 of the California Labor Code, Consultant shall be required to secure workers’ compensation coverage for its employees. If any class of employee or employees engaged in performing any portion of the Services under this Agreement are not protected under the Workers’ Compensation Statute, adequate insurance coverage for the protection of any employee(s) not otherwise protected must be obtained before any of those employee(s) commence performing any portion of the Services.

16.1.3. **Professional Liability (Errors and Omissions).** Professional Liability Insurance as appropriate to Consultant’s profession, coverage to continue through completion of construction plus three (3) years thereafter.

16.2. **Proof of Carriage of Insurance.** Consultant shall not commence performing any portion of the Services until all required insurance has been obtained and certificates and endorsements indicating the required coverage have been delivered in duplicate to District and approved by District. Certificates and insurance policies shall include the following:

- 16.2.1. A clause stating: “This policy shall not be canceled or reduced in required limits of liability or amounts of insurance until notice has been mailed to District, stating date of cancellation or reduction. Date of cancellation or reduction shall not be less than thirty (30) days after date of mailing notice.”
- 16.2.2. Language stating in particular those insured, extent of insurance, location and operation to which insurance applies, expiration date, to whom cancellation and reduction notice will be sent, and length of notice period.
- 16.2.3. An endorsement stating that District and its Board of Trustees, agents, representatives, employees, trustees, officers, consultants, and volunteers are named additional insured under all policies except Workers’ Compensation Insurance, Professional Liability, and Employers’ Liability Insurance. An endorsement shall also state that Consultant’s insurance policies shall be primary to any insurance or self-insurance maintained by District. An endorsement shall also state that there shall be a waiver of any subrogation.
- 16.2.4. All policies except the Professional Liability, Workers’ Compensation Insurance, and Employer’s Liability Insurance Policies shall be written on an occurrence form.
- 16.2.5. If CONSULTANT normally carries insurance in an amount greater than the minimum amounts required herein, that greater amount shall become the minimum required amount of insurance for purposes of the Agreement. Therefore, CONSULTANT hereby acknowledges and agrees that all insurance carried by it shall be deemed liability coverage for all actions it performs in connection with the Agreement.
- 16.2.6. Upon District’s request, CONSULTANT will furnish District with a copy of all insurance policies related to its provision of Services under this Agreement.

16.3. **Acceptability of Insurers.** Insurance is to be placed with insurers with a current A.M. Best’s rating of no less than A: VII, unless otherwise acceptable to District.

17. **Compliance with Laws.** Consultant shall observe and comply with all rules and regulations of the governing board of District and all federal, state, and local laws, ordinances and regulations. Consultant shall give all notices required by any law, ordinance, rule and regulation bearing on conduct of the Services as indicated or specified. If Consultant observes that any of the Services required by this Contract is at variance with any such laws, ordinance, rules or regulations, Consultant shall notify District, in writing, and, at the sole option of District, any necessary changes to the scope of the Services shall be made and this Agreement shall be appropriately amended in writing, or this Agreement shall be terminated effective upon Consultant’s receipt of a written termination notice from District. If Consultant performs any Services that is in violation

of any laws, ordinances, rules or regulations, without first notifying District of the violation, Consultant shall bear all costs arising therefrom.

18. **Certificates/Permits/Licenses/Registrations.** Consultant and all Consultant's employees or agents shall secure and maintain in force such certificates, permits, licenses, and registrations as are required by law in connection with the furnishing of Services pursuant to this Agreement.
19. **COVID-19 Requirements.** For all workers on District property, CONSULTANT shall comply with all applicable federal, state and local laws regarding COVID-19. Further, except to the extent the Order provides otherwise, CONSULTANT and CONSULTANT's personnel shall continue to comply with all other applicable terms in the CDPH's State Public Health Officer Orders.
20. **Anti-Discrimination.** The District's policy in connection with all work performed under District contracts is there to be no discrimination against any employee engaged in the work because of race, color, ancestry, national origin, religious creed, physical disability, medical condition, marital status, sexual orientation, gender, or age. Therefore, Consultant agrees to comply with applicable Federal and California laws including, but not limited to, the California Fair Employment and Housing Act beginning with Government Code Section 12900 and Labor Code Section 1735 and District policy. In addition, Consultant agrees to require like compliance by all of its subcontractor(s).
21. **Priority of Documents.** To the extent there is a conflict between this Agreement and any attachments hereto or documents incorporated by reference, this Agreement shall control. In the event of a conflict as between other documents the order of priority shall be as follows: Appendix A, Appendix B, the RFP and the Proposal.
22. **No Rights in Third Parties.** This Agreement does not create any rights in, or inure to the benefit of, any third party except as expressly provided herein.
23. **Limitation of District Liability.**
  - 23.1. Other than as provided in this Agreement, District's financial obligations under this Agreement shall be limited to the payment of the compensation provided in this Agreement. Notwithstanding any other provision of this Agreement, in no event, shall District be liable, regardless of whether any claim is based on contract or tort, for any special, consequential, indirect or incidental damages including, but not limited to, lost profits or revenue, arising out of or in connection with this Agreement for the Services performed in connection with this Agreement.
  - 23.2. CONSULTANT hereby waives any and all claim(s) for recovery from District under this Agreement, which loss or damage is covered by valid and collectible insurance policies. CONSULTANT agrees to have its required insurance policies endorsed to prevent the invalidation of insurance coverages by reason of this waiver. This waiver shall extend to claims paid, or expenses incurred, by CONSULTANT's insurance company on District's behalf.
24. **Confidentiality.** Consultant and all Consultant's agents, personnel, employee(s), and/or subcontractor(s) shall maintain the confidentiality of all information received in the course of performing the Services. Consultant understands that student records are confidential and agrees

to comply with all state and federal laws concerning the maintenance and disclosure of student records. This requirement to maintain confidentiality shall extend beyond the termination of this Agreement.

25. **Notice.** Any notice required or permitted to be given under this Agreement shall be deemed to have been given, served, and received if given in writing and either personally delivered or deposited in the United States mail, registered or certified mail, postage prepaid, return receipt required, or sent by overnight delivery service, or electronic transmission, addressed as follows:

**District:**

Placentia Library District  
 411 E. Chapman Ave.  
 Placentia, CA 92870

ATTN: \_\_\_\_\_

Email: \_\_\_\_\_

**Consultant:**

\_\_\_\_\_

\_\_\_\_\_

ATTN: \_\_\_\_\_

Email: \_\_\_\_\_

Any notice personally given or sent by electronic transmission shall be effective upon receipt. Any notice sent by overnight delivery service shall be effective the business day next following delivery thereof to the overnight delivery service. Any notice given by mail shall be effective three (3) days after deposit in the United States mail.

26. **Integration/Entire Agreement of Parties.** This Agreement and any documents attached hereto or incorporated herein by reference, constitutes the entire agreement between the Parties and supersedes all prior discussions, negotiations, and agreements, whether oral or written. This Agreement may be amended or modified only by a written instrument executed by both Parties.
27. **California Law.** This Agreement shall be governed by and the rights, duties and obligations of the Parties shall be determined and enforced in accordance with the laws of the State of California. The Parties further agree that any action or proceeding brought to enforce the terms and conditions of this Agreement shall be maintained in the county in which District’s administrative offices are located.
28. **Waiver.** The waiver by either party of any breach of any term, covenant, or condition herein contained shall not be deemed to be a waiver of such term, covenant, condition, or any subsequent breach of the same or any other term, covenant, or condition herein contained.
29. **Severability.** If any term, condition or provision of this Agreement is held by a court of competent jurisdiction to be invalid, void or unenforceable, the remaining provisions will nevertheless continue in full force and effect, and shall not be affected, impaired or invalidated in any way.
30. **Authority to Bind Parties.** Neither party in the performance of any and all duties under this Agreement, except as otherwise provided in this Agreement, has any authority to bind the other to any agreements or undertakings.



- 31. **Captions and Interpretations.** Paragraph headings in this Agreement are used solely for convenience, and shall be wholly disregarded in the construction of this Agreement. No provision of this Agreement shall be interpreted for or against a party because that party or its legal representative drafted such provision, and this Agreement shall be construed as if jointly prepared by the Parties.
- 32. **Calculation of Time.** For the purposes of this Agreement, “days” refers to calendar days unless otherwise specified.
- 33. **Signature Authority.** Each party has the full power and authority to enter into and perform this Agreement, and the person signing this Agreement on behalf of each Party has been properly authority and empowered to enter into this Agreement.
- 34. **Counterparts.** This Agreement may be executed in one or more counterparts, and all counterparts together shall be construed as one document. A facsimile or electronic signature shall be deemed to be the equivalent of the actual original signature. All counterparts so executed shall constitute one Agreement binding all the Parties hereto.
- 35. **Incorporation of Recitals and Appendices.** The Recitals and each appendix attached hereto, the RFP and the Proposal are hereby incorporated herein by reference.

IN WITNESS WHEREOF, the Parties hereto have executed this Agreement on the date indicated below.

Dated: \_\_\_\_\_, 202\_\_

Dated: \_\_\_\_\_, 202\_\_

**Placentia Library District**

**[Consultant Name]**

Signed By: \_\_\_\_\_

Signed By: \_\_\_\_\_

Print Name: \_\_\_\_\_

Print Name: \_\_\_\_\_

Print Title: \_\_\_\_\_

Print Title: \_\_\_\_\_

Approved as to form:

\_\_\_\_\_

David DeBerry, District General Counsel





**2022 CALIFORNIA GREEN BUILDING STANDARDS CODE**  
NONRESIDENTIAL MANDATORY MEASURES, SHEET 1 (January 2023)

**CHAPTER 3**  
**GREEN BUILDING**

**SECTION 3.1 GENERAL**

3.1.1 SCOPE: All buildings with a floor area of 50,000 square feet or greater... shall comply with the minimum requirements of this code for green building... unless otherwise specified.

3.1.2 ADMINISTRATION: The minimum requirements of this code shall be enforced by the local authority having jurisdiction... unless otherwise specified.

3.1.3 PERFORMANCE: The minimum requirements of this code shall be achieved by the design and construction of the building... unless otherwise specified.

**SECTION 3.2 ENERGY EFFICIENCY**

3.2.1 ENERGY EFFICIENCY RATING: The minimum requirements of this code shall be achieved by the design and construction of the building... unless otherwise specified.

**SECTION 3.3 WATER EFFICIENCY**

3.3.1 WATER EFFICIENCY RATING: The minimum requirements of this code shall be achieved by the design and construction of the building... unless otherwise specified.

**SECTION 3.4 AIR QUALITY**

3.4.1 AIR QUALITY RATING: The minimum requirements of this code shall be achieved by the design and construction of the building... unless otherwise specified.

**SECTION 3.5 HEALTH AND WELLBEING**

3.5.1 HEALTH AND WELLBEING RATING: The minimum requirements of this code shall be achieved by the design and construction of the building... unless otherwise specified.

**SECTION 3.6 MATERIALS AND RESOURCES**

3.6.1 MATERIALS AND RESOURCES RATING: The minimum requirements of this code shall be achieved by the design and construction of the building... unless otherwise specified.

**SECTION 3.7 COMMUNITY ENGAGEMENT**

3.7.1 COMMUNITY ENGAGEMENT RATING: The minimum requirements of this code shall be achieved by the design and construction of the building... unless otherwise specified.

**SECTION 3.8 LEADERSHIP IN DESIGN**

3.8.1 LEADERSHIP IN DESIGN RATING: The minimum requirements of this code shall be achieved by the design and construction of the building... unless otherwise specified.

ELEMENT TYPE	BACKGROUND (SEE THE CODE)	MINIMUM REQUIREMENTS (SEE THE CODE)	COMPLIANCE TYPE	TABLE 1.1.1.1.1 - MINIMUM REQUIREMENTS FOR ENERGY EFFICIENCY RATING	
				COMPLIANCE TYPE	COMPLIANCE TYPE
Energy	ASHRAE 90.1-2010	Energy Star	Energy Star	Energy Star	Energy Star
Water	ASHRAE 90.1-2010	Water Star	Water Star	Water Star	Water Star
Air Quality	ASHRAE 90.1-2010	IAQ	IAQ	IAQ	IAQ

**SECTION 4.1 GENERAL**

4.1.1 SCOPE: All buildings with a floor area of 50,000 square feet or greater... shall comply with the minimum requirements of this code for green building... unless otherwise specified.

4.1.2 ADMINISTRATION: The minimum requirements of this code shall be enforced by the local authority having jurisdiction... unless otherwise specified.

4.1.3 PERFORMANCE: The minimum requirements of this code shall be achieved by the design and construction of the building... unless otherwise specified.

**placentia**  
LIBRARY DISTRICT

411 E. CHAMPAIN AVE.  
PLACENTIA, CA 92869

**IDS GROUP**

1 PETERS CANON ROAD, SUITE 130  
IRVINE, CA 92618  
TEL: 949.541.9288 FAX: 949.541.0890

**PROJECT**  
OUTDOOR LIBRARY

**PROJECT #**  
411 E CHAMPAIN AVE.  
PLACENTIA, CA 92869

---

**PROJECT IDENTIFICATION**

PROJECT NAME: OUTDOOR LIBRARY

PROJECT NUMBER: 411 E CHAMPAIN AVE. PLACENTIA, CA 92869

**DESIGNER**  
IDS GROUP

1 PETERS CANON ROAD, SUITE 130  
IRVINE, CA 92618  
TEL: 949.541.9288 FAX: 949.541.0890

**DATE**  
2023-10-10

**REVISIONS**

NO.	DESCRIPTION	DATE
1	FINAL CHECK SHEET	10/10/23

California  
2022 CALIFORNIA GREEN BUILDING STANDARDS CODE  
NONRESIDENTIAL MANDATORY MEASURES, SHEET 2 (January 2023)

Table with 10 columns: Section Number, Section Title, Description, and Code Reference. Rows include sections such as 5.2.01, 5.2.02, 5.2.03, 5.2.04, 5.2.05, 5.2.06, 5.2.07, 5.2.08, 5.2.09, 5.2.10, 5.2.11, 5.2.12, 5.2.13, 5.2.14, 5.2.15, 5.2.16, 5.2.17, 5.2.18, 5.2.19, 5.2.20, 5.2.21, 5.2.22, 5.2.23, 5.2.24, 5.2.25, 5.2.26, 5.2.27, 5.2.28, 5.2.29, 5.2.30, 5.2.31, 5.2.32, 5.2.33, 5.2.34, 5.2.35, 5.2.36, 5.2.37, 5.2.38, 5.2.39, 5.2.40, 5.2.41, 5.2.42, 5.2.43, 5.2.44, 5.2.45, 5.2.46, 5.2.47, 5.2.48, 5.2.49, 5.2.50, 5.2.51, 5.2.52, 5.2.53, 5.2.54, 5.2.55, 5.2.56, 5.2.57, 5.2.58, 5.2.59, 5.2.60, 5.2.61, 5.2.62, 5.2.63, 5.2.64, 5.2.65, 5.2.66, 5.2.67, 5.2.68, 5.2.69, 5.2.70, 5.2.71, 5.2.72, 5.2.73, 5.2.74, 5.2.75, 5.2.76, 5.2.77, 5.2.78, 5.2.79, 5.2.80, 5.2.81, 5.2.82, 5.2.83, 5.2.84, 5.2.85, 5.2.86, 5.2.87, 5.2.88, 5.2.89, 5.2.90, 5.2.91, 5.2.92, 5.2.93, 5.2.94, 5.2.95, 5.2.96, 5.2.97, 5.2.98, 5.2.99, 5.2.100.

PROJECT INFORMATION: 411 E CHAPMAN AVE, PLACENTIA, CA 92670. PROJECT NAME: OUTDOOR LIBRARY. ARCHITECT: IDS GROUP. SHEET NO. 4 OF 53. PROJECT IDENTIFICATION: PROJECT NO. 23117.00, SHEET NO. 4 OF 53. PROJECT LOCATION: 411 E CHAPMAN AVE, PLACENTIA, CA 92670. PROJECT OWNER: PLACENTIA LIBRARY DISTRICT. PROJECT ARCHITECT: IDS GROUP. PROJECT ENGINEER: MARLOU FRANCISCO. PROJECT DATE: 8/20/2024.





**California**  
**2022 CALIFORNIA GREEN BUILDING STANDARDS CODE**  
**NONRESIDENTIAL MANDATORY MEASURES, SHEET 3 (January 2023)**

SECTION	SECTION TITLE	SECTION DESCRIPTION	COMMITTEE NO. LIMIT
<b>TABLE E-504.2.1 - ADHERENCE (VOC) LIMITS</b>			
504.2.1.1	ADHERENCE (VOC) LIMITS	Adherence (VOC) Limit	250
504.2.1.2	ADHERENCE (VOC) LIMITS	Adherence (VOC) Limit	250
504.2.1.3	ADHERENCE (VOC) LIMITS	Adherence (VOC) Limit	250
504.2.1.4	ADHERENCE (VOC) LIMITS	Adherence (VOC) Limit	250
504.2.1.5	ADHERENCE (VOC) LIMITS	Adherence (VOC) Limit	250
504.2.1.6	ADHERENCE (VOC) LIMITS	Adherence (VOC) Limit	250
504.2.1.7	ADHERENCE (VOC) LIMITS	Adherence (VOC) Limit	250
504.2.1.8	ADHERENCE (VOC) LIMITS	Adherence (VOC) Limit	250
504.2.1.9	ADHERENCE (VOC) LIMITS	Adherence (VOC) Limit	250
504.2.1.10	ADHERENCE (VOC) LIMITS	Adherence (VOC) Limit	250
504.2.1.11	ADHERENCE (VOC) LIMITS	Adherence (VOC) Limit	250
504.2.1.12	ADHERENCE (VOC) LIMITS	Adherence (VOC) Limit	250
504.2.1.13	ADHERENCE (VOC) LIMITS	Adherence (VOC) Limit	250
504.2.1.14	ADHERENCE (VOC) LIMITS	Adherence (VOC) Limit	250
504.2.1.15	ADHERENCE (VOC) LIMITS	Adherence (VOC) Limit	250
504.2.1.16	ADHERENCE (VOC) LIMITS	Adherence (VOC) Limit	250
504.2.1.17	ADHERENCE (VOC) LIMITS	Adherence (VOC) Limit	250
504.2.1.18	ADHERENCE (VOC) LIMITS	Adherence (VOC) Limit	250
504.2.1.19	ADHERENCE (VOC) LIMITS	Adherence (VOC) Limit	250
504.2.1.20	ADHERENCE (VOC) LIMITS	Adherence (VOC) Limit	250
504.2.1.21	ADHERENCE (VOC) LIMITS	Adherence (VOC) Limit	250
504.2.1.22	ADHERENCE (VOC) LIMITS	Adherence (VOC) Limit	250
504.2.1.23	ADHERENCE (VOC) LIMITS	Adherence (VOC) Limit	250
504.2.1.24	ADHERENCE (VOC) LIMITS	Adherence (VOC) Limit	250
504.2.1.25	ADHERENCE (VOC) LIMITS	Adherence (VOC) Limit	250
504.2.1.26	ADHERENCE (VOC) LIMITS	Adherence (VOC) Limit	250
504.2.1.27	ADHERENCE (VOC) LIMITS	Adherence (VOC) Limit	250
504.2.1.28	ADHERENCE (VOC) LIMITS	Adherence (VOC) Limit	250
504.2.1.29	ADHERENCE (VOC) LIMITS	Adherence (VOC) Limit	250
504.2.1.30	ADHERENCE (VOC) LIMITS	Adherence (VOC) Limit	250
504.2.1.31	ADHERENCE (VOC) LIMITS	Adherence (VOC) Limit	250
504.2.1.32	ADHERENCE (VOC) LIMITS	Adherence (VOC) Limit	250
504.2.1.33	ADHERENCE (VOC) LIMITS	Adherence (VOC) Limit	250
504.2.1.34	ADHERENCE (VOC) LIMITS	Adherence (VOC) Limit	250
504.2.1.35	ADHERENCE (VOC) LIMITS	Adherence (VOC) Limit	250
504.2.1.36	ADHERENCE (VOC) LIMITS	Adherence (VOC) Limit	250
504.2.1.37	ADHERENCE (VOC) LIMITS	Adherence (VOC) Limit	250
504.2.1.38	ADHERENCE (VOC) LIMITS	Adherence (VOC) Limit	250
504.2.1.39	ADHERENCE (VOC) LIMITS	Adherence (VOC) Limit	250
504.2.1.40	ADHERENCE (VOC) LIMITS	Adherence (VOC) Limit	250
504.2.1.41	ADHERENCE (VOC) LIMITS	Adherence (VOC) Limit	250
504.2.1.42	ADHERENCE (VOC) LIMITS	Adherence (VOC) Limit	250
504.2.1.43	ADHERENCE (VOC) LIMITS	Adherence (VOC) Limit	250
504.2.1.44	ADHERENCE (VOC) LIMITS	Adherence (VOC) Limit	250
504.2.1.45	ADHERENCE (VOC) LIMITS	Adherence (VOC) Limit	250
504.2.1.46	ADHERENCE (VOC) LIMITS	Adherence (VOC) Limit	250
504.2.1.47	ADHERENCE (VOC) LIMITS	Adherence (VOC) Limit	250
504.2.1.48	ADHERENCE (VOC) LIMITS	Adherence (VOC) Limit	250
504.2.1.49	ADHERENCE (VOC) LIMITS	Adherence (VOC) Limit	250
504.2.1.50	ADHERENCE (VOC) LIMITS	Adherence (VOC) Limit	250
504.2.1.51	ADHERENCE (VOC) LIMITS	Adherence (VOC) Limit	250
504.2.1.52	ADHERENCE (VOC) LIMITS	Adherence (VOC) Limit	250
504.2.1.53	ADHERENCE (VOC) LIMITS	Adherence (VOC) Limit	250
504.2.1.54	ADHERENCE (VOC) LIMITS	Adherence (VOC) Limit	250
504.2.1.55	ADHERENCE (VOC) LIMITS	Adherence (VOC) Limit	250
504.2.1.56	ADHERENCE (VOC) LIMITS	Adherence (VOC) Limit	250
504.2.1.57	ADHERENCE (VOC) LIMITS	Adherence (VOC) Limit	250
504.2.1.58	ADHERENCE (VOC) LIMITS	Adherence (VOC) Limit	250
504.2.1.59	ADHERENCE (VOC) LIMITS	Adherence (VOC) Limit	250
504.2.1.60	ADHERENCE (VOC) LIMITS	Adherence (VOC) Limit	250
504.2.1.61	ADHERENCE (VOC) LIMITS	Adherence (VOC) Limit	250
504.2.1.62	ADHERENCE (VOC) LIMITS	Adherence (VOC) Limit	250
504.2.1.63	ADHERENCE (VOC) LIMITS	Adherence (VOC) Limit	250
504.2.1.64	ADHERENCE (VOC) LIMITS	Adherence (VOC) Limit	250
504.2.1.65	ADHERENCE (VOC) LIMITS	Adherence (VOC) Limit	250
504.2.1.66	ADHERENCE (VOC) LIMITS	Adherence (VOC) Limit	250
504.2.1.67	ADHERENCE (VOC) LIMITS	Adherence (VOC) Limit	250
504.2.1.68	ADHERENCE (VOC) LIMITS	Adherence (VOC) Limit	250
504.2.1.69	ADHERENCE (VOC) LIMITS	Adherence (VOC) Limit	250
504.2.1.70	ADHERENCE (VOC) LIMITS	Adherence (VOC) Limit	250
504.2.1.71	ADHERENCE (VOC) LIMITS	Adherence (VOC) Limit	250
504.2.1.72	ADHERENCE (VOC) LIMITS	Adherence (VOC) Limit	250
504.2.1.73	ADHERENCE (VOC) LIMITS	Adherence (VOC) Limit	250
504.2.1.74	ADHERENCE (VOC) LIMITS	Adherence (VOC) Limit	250
504.2.1.75	ADHERENCE (VOC) LIMITS	Adherence (VOC) Limit	250
504.2.1.76	ADHERENCE (VOC) LIMITS	Adherence (VOC) Limit	250
504.2.1.77	ADHERENCE (VOC) LIMITS	Adherence (VOC) Limit	250
504.2.1.78	ADHERENCE (VOC) LIMITS	Adherence (VOC) Limit	250
504.2.1.79	ADHERENCE (VOC) LIMITS	Adherence (VOC) Limit	250
504.2.1.80	ADHERENCE (VOC) LIMITS	Adherence (VOC) Limit	250
504.2.1.81	ADHERENCE (VOC) LIMITS	Adherence (VOC) Limit	250
504.2.1.82	ADHERENCE (VOC) LIMITS	Adherence (VOC) Limit	250
504.2.1.83	ADHERENCE (VOC) LIMITS	Adherence (VOC) Limit	250
504.2.1.84	ADHERENCE (VOC) LIMITS	Adherence (VOC) Limit	250
504.2.1.85	ADHERENCE (VOC) LIMITS	Adherence (VOC) Limit	250
504.2.1.86	ADHERENCE (VOC) LIMITS	Adherence (VOC) Limit	250
504.2.1.87	ADHERENCE (VOC) LIMITS	Adherence (VOC) Limit	250
504.2.1.88	ADHERENCE (VOC) LIMITS	Adherence (VOC) Limit	250
504.2.1.89	ADHERENCE (VOC) LIMITS	Adherence (VOC) Limit	250
504.2.1.90	ADHERENCE (VOC) LIMITS	Adherence (VOC) Limit	250
504.2.1.91	ADHERENCE (VOC) LIMITS	Adherence (VOC) Limit	250
504.2.1.92	ADHERENCE (VOC) LIMITS	Adherence (VOC) Limit	250
504.2.1.93	ADHERENCE (VOC) LIMITS	Adherence (VOC) Limit	250
504.2.1.94	ADHERENCE (VOC) LIMITS	Adherence (VOC) Limit	250
504.2.1.95	ADHERENCE (VOC) LIMITS	Adherence (VOC) Limit	250
504.2.1.96	ADHERENCE (VOC) LIMITS	Adherence (VOC) Limit	250
504.2.1.97	ADHERENCE (VOC) LIMITS	Adherence (VOC) Limit	250
504.2.1.98	ADHERENCE (VOC) LIMITS	Adherence (VOC) Limit	250
504.2.1.99	ADHERENCE (VOC) LIMITS	Adherence (VOC) Limit	250
504.2.1.100	ADHERENCE (VOC) LIMITS	Adherence (VOC) Limit	250

CLIENT: GORD AND GORDEN A&B  
411 E. CHAPMAN AVE.  
PLACENTIA, CA 92679

**placentia**  
LIBRARY DISTRICT

**OUTDOOR LIBRARY**

411 E. CHAPMAN AVE  
PLACENTIA, CA 92679

PROJECT NO.: 23117.00

DESIGNER:  
IDS GROUP

1 PETERS CAMPBELL SUITE 100  
DOWNE CANYON CA 92630  
TEL: 949-981-8800 FAX: 949-981-4000

DATE: 8/20/2024 2:14:15 PM

USER: Auther

**CHAPTER 7  
INSTALLER & SPECIAL INSPECTOR QUALIFICATIONS**

**701 INSPECTOR TRAINING.** All installers and special inspectors shall be trained and certified in the installation and inspection of the equipment and systems specified in this code. The training shall be provided by the manufacturer of the equipment and systems or by a training organization approved by the authority having jurisdiction. The training shall include the following:

1. Knowledge of the manufacturer's installation and inspection instructions.
2. Knowledge of the applicable code requirements.
3. Knowledge of the safety procedures for the installation and inspection of the equipment and systems.

**702 VERIFICATION.** The installer and special inspector shall verify that the equipment and systems have been installed and inspected in accordance with the manufacturer's instructions and the applicable code requirements. The verification shall be documented in a written report.

**703 QUALIFICATION.** The installer and special inspector shall be qualified to perform the installation and inspection of the equipment and systems specified in this code. The qualification shall be based on the following:

1. Successful completion of the training program.
2. Successful completion of a written examination.
3. Successful completion of a practical examination.

**704 CERTIFICATION.** The installer and special inspector shall be certified by the authority having jurisdiction. The certification shall be based on the following:

1. Successful completion of the training program.
2. Successful completion of a written examination.
3. Successful completion of a practical examination.
4. Successful completion of a background check.

**705 MAINTENANCE.** The installer and special inspector shall provide the owner with written instructions on the proper maintenance and operation of the equipment and systems. The instructions shall include the following:

1. The name and contact information of the manufacturer.
2. The name and contact information of the installer and special inspector.
3. The name and contact information of the authority having jurisdiction.
4. The name and contact information of the training organization.

REV.	DESCRIPTION	DATE
1	ISSUED FOR PERMIT	08/20/2024
2	FOR CONSTRUCTION	08/20/2024
3	FOR PERMITTING	08/20/2024

**PROJECT IDENTIFICATION**

PROJECT NO.: 23117.00  
OWNER: GORD AND GORDEN A&B  
ADDRESS: 411 E. CHAPMAN AVE.  
CITY: PLACENTIA, CA 92679

**DESIGNER**

IDS GROUP  
1 PETERS CAMPBELL SUITE 100  
DOWNE CANYON CA 92630  
TEL: 949-981-8800 FAX: 949-981-4000

**DATE**

8/20/2024 2:14:15 PM

**USER**

Auther

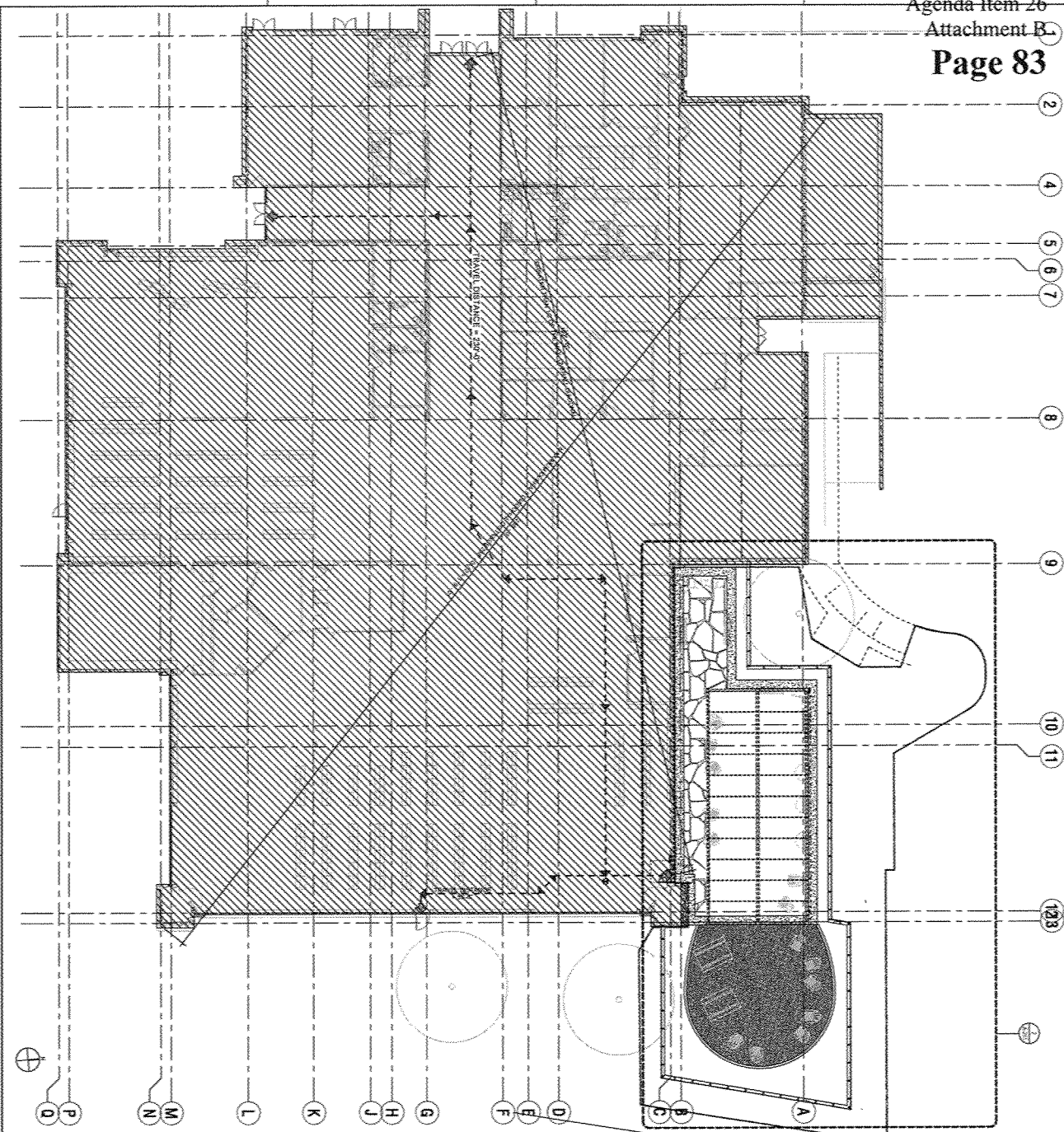

**CODE REQUIREMENTS**

**MINIMUM CLEARANCE**  
MINIMUM CLEARANCE SHALL BE MAINTAINED AT ALL TIMES TO ALLOW FOR THE PROPER OPERATION OF THE VEHICLE.  
MINIMUM CLEARANCE SHALL BE MAINTAINED AT ALL TIMES TO ALLOW FOR THE PROPER OPERATION OF THE VEHICLE.  
MINIMUM CLEARANCE SHALL BE MAINTAINED AT ALL TIMES TO ALLOW FOR THE PROPER OPERATION OF THE VEHICLE.

**LEGEND**

- INDICATES AREA ACCESSIBLE FROM OTHER SIDE OF TRAVEL
- INDICATES EXITS ABOUT DIRECTION OF TRAVEL
- UNOCCUPIED PER ROOM
- NOT IN CONTACT WITH
- ▨ LIMIT OF WORK
- ▧ REQUIRED DOOR CLEARANCE
- ▩ DOOR SWING
- ▭ PROPERTY LINE REFERS TO ADJ. PARCELS (SHOWN ONLY)

**REFERENCES**

FOR BUILDING OCCUPANCY AND PLUMBING REQUIREMENTS, REFER TO THE PROJECT MANUAL AND SPECIFICATIONS TO THE PROJECT MANUAL.



411 E. CHAPMAN AVE.  
PLACENTIA, CA 92679

**OUTDOOR LIBRARY**

411 E. CHAPMAN AVE.  
PLACENTIA, CA 92679



1 FETTER CANYON ROAD, SUITE 100  
IRVINE, CA 92618  
TEL: 949-251-4000 FAX: 949-251-2880



REV.	DESCRIPTION	DATE
1	ISSUE FOR PERMIT	08/20/24

**PROJECT IDENTIFICATION**  
PROJECT NAME: OUTDOOR LIBRARY  
PROJECT NO.: 231117\_00  
SHEET NO.: G-120

**DESIGNER**  
DESIGNED BY: ALBERT  
CHECKED BY: CHUCK  
APPROVED BY: [Signature]

**EXIT AND OCCUPANCY ANALYSIS PLAN**  
SHEET NO. 8 OF 53

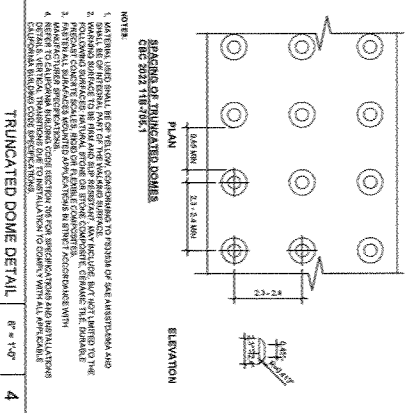
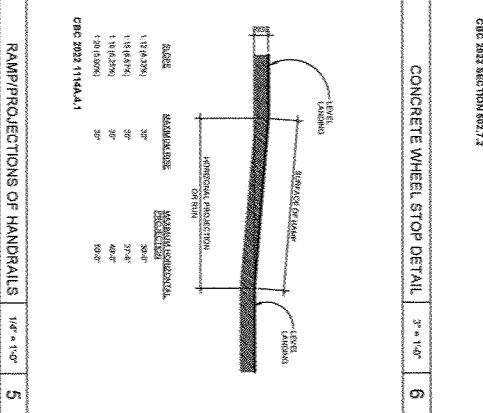
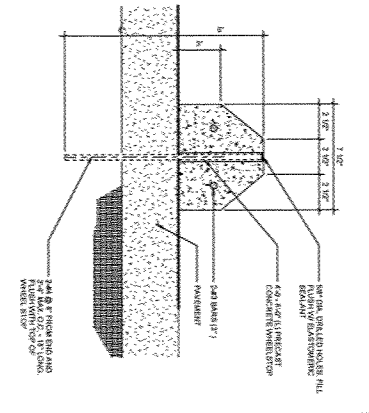
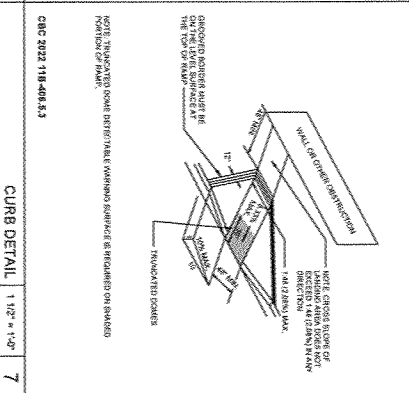
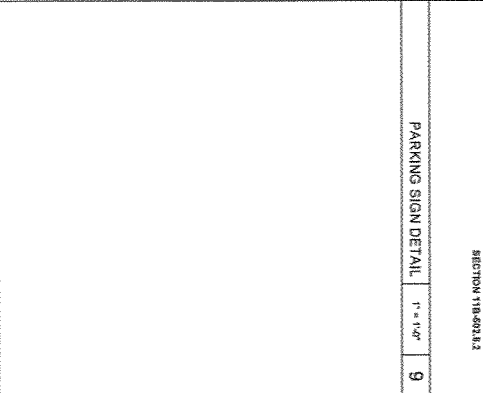
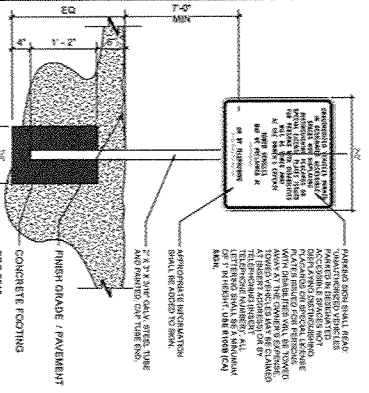
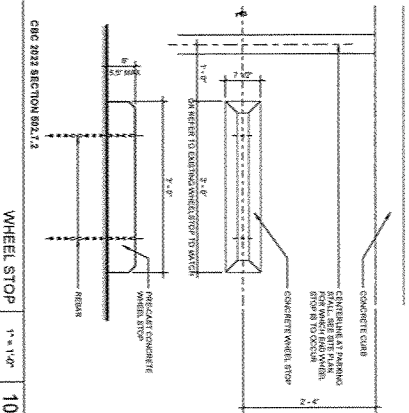
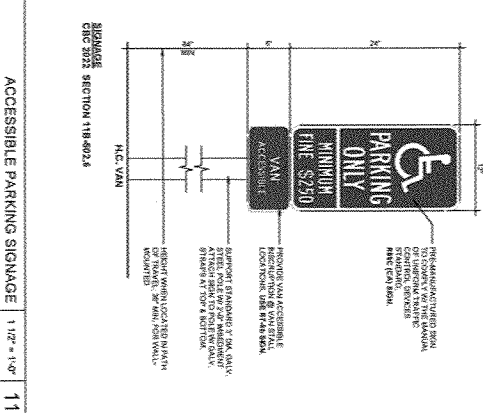
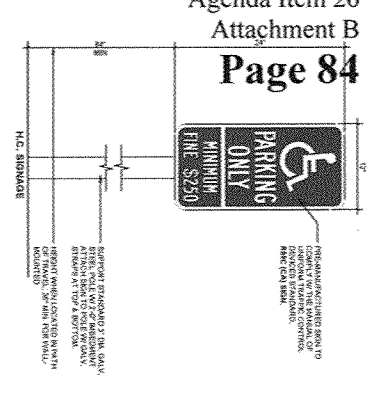

**SITE ACCESS NOTES**

1. ALL ACCESSIBLE ROUTES SHALL BE MAINTAINED AT ALL TIMES TO BE ACCESSIBLE TO ALL INDIVIDUALS WITH PHYSICAL AND SENSORY DISABILITIES.

2. ALL ACCESSIBLE ROUTES SHALL BE MAINTAINED AT ALL TIMES TO BE ACCESSIBLE TO ALL INDIVIDUALS WITH PHYSICAL AND SENSORY DISABILITIES.

3. ALL ACCESSIBLE ROUTES SHALL BE MAINTAINED AT ALL TIMES TO BE ACCESSIBLE TO ALL INDIVIDUALS WITH PHYSICAL AND SENSORY DISABILITIES.

4. ALL ACCESSIBLE ROUTES SHALL BE MAINTAINED AT ALL TIMES TO BE ACCESSIBLE TO ALL INDIVIDUALS WITH PHYSICAL AND SENSORY DISABILITIES.

**ADA STANDARDS, 2010**

1. ALL ACCESSIBLE ROUTES SHALL BE MAINTAINED AT ALL TIMES TO BE ACCESSIBLE TO ALL INDIVIDUALS WITH PHYSICAL AND SENSORY DISABILITIES.

2. ALL ACCESSIBLE ROUTES SHALL BE MAINTAINED AT ALL TIMES TO BE ACCESSIBLE TO ALL INDIVIDUALS WITH PHYSICAL AND SENSORY DISABILITIES.

3. ALL ACCESSIBLE ROUTES SHALL BE MAINTAINED AT ALL TIMES TO BE ACCESSIBLE TO ALL INDIVIDUALS WITH PHYSICAL AND SENSORY DISABILITIES.

4. ALL ACCESSIBLE ROUTES SHALL BE MAINTAINED AT ALL TIMES TO BE ACCESSIBLE TO ALL INDIVIDUALS WITH PHYSICAL AND SENSORY DISABILITIES.

**ADA STANDARDS, 2010**

1. ALL ACCESSIBLE ROUTES SHALL BE MAINTAINED AT ALL TIMES TO BE ACCESSIBLE TO ALL INDIVIDUALS WITH PHYSICAL AND SENSORY DISABILITIES.

2. ALL ACCESSIBLE ROUTES SHALL BE MAINTAINED AT ALL TIMES TO BE ACCESSIBLE TO ALL INDIVIDUALS WITH PHYSICAL AND SENSORY DISABILITIES.

3. ALL ACCESSIBLE ROUTES SHALL BE MAINTAINED AT ALL TIMES TO BE ACCESSIBLE TO ALL INDIVIDUALS WITH PHYSICAL AND SENSORY DISABILITIES.

4. ALL ACCESSIBLE ROUTES SHALL BE MAINTAINED AT ALL TIMES TO BE ACCESSIBLE TO ALL INDIVIDUALS WITH PHYSICAL AND SENSORY DISABILITIES.

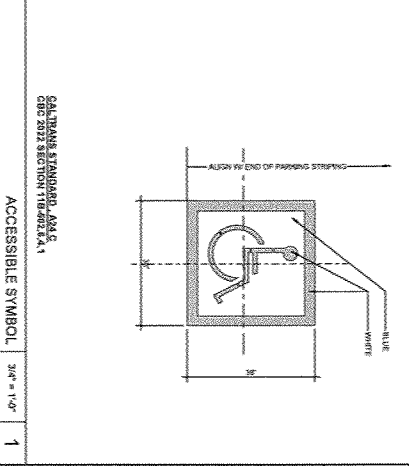

**placentia**  
LIBRARY DISTRICT

CLERK: LUCAS AND JENNIFER AEA  
411 E. CLAYMAN AVE  
PLACENTIA, CA 92679

**OUTDOOR LIBRARY**

411 E. CLAYMAN AVE  
PLACENTIA, CA 92679

**IDS GROUP**

1 PETER CANNON ROAD, SUITE 130  
PINKNEY, CA 95058  
TEL: 925-937-1500 FAX: 925-937-0800

**PROJECT IDENTIFICATION**

PROJECT NO. 233117.00  
PROJECT NAME: PLACENTIA LIBRARY DISTRICT  
PROJECT LOCATION: 411 E. CLAYMAN AVE, PLACENTIA, CA 92679  
PROJECT DATE: 8/20/2024

**REVISIONS**

NO.	DESCRIPTION	DATE
1	ISSUED FOR PERMITTING	8/20/2024
2	REVISIONS TO PERMITTING	8/20/2024
3	REVISIONS TO PERMITTING	8/20/2024
4	REVISIONS TO PERMITTING	8/20/2024

**APPROVED BY:** [Signature]  
**CHECKED BY:** [Signature]  
**DATE:** 8/20/2024



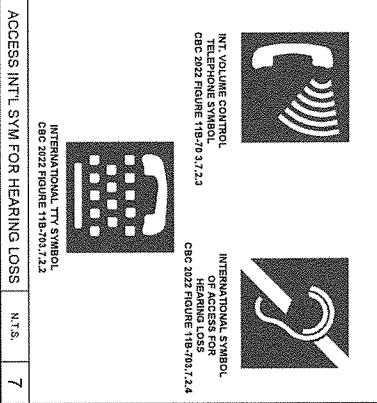
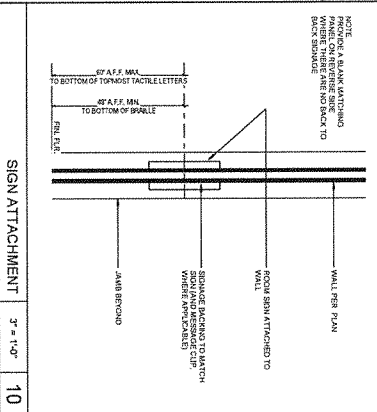
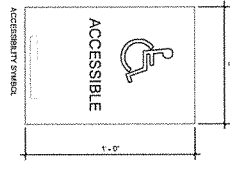
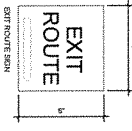
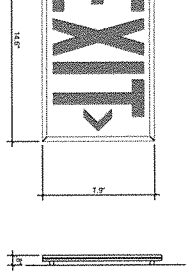

NOTE: ALL SIGNAGE SHALL BE MOUNTED ON EXTERIOR WALLS AND BE PROTECTED FROM VANDALISM AND WEATHERING... 1. SIGN LETTERS TO BE 1/2\"/>

MINIMUM REQUIRED DOOR CLEARANCE INTERIOR OR EXTERIOR DOOR - A LEVEL AND CLEAR FLOOR OR LANDING ON EACH SIDE OF DOOR SHALL BE PROVIDED... DOOR CLEARANCE 1/4\"/>

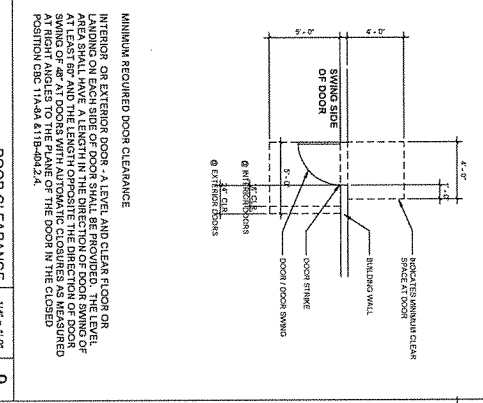

BUILDING ACCESS BUILDING ENTRANCES TO BE ACCESSIBLE... 1. BUILDING ENTRANCES TO BE ACCESSIBLE... 2. BUILDING ENTRANCES TO BE ACCESSIBLE... 3. BUILDING ENTRANCES TO BE ACCESSIBLE...

PATH OF TRAVEL AND ACCESSIBLE ROUTE ALL ACCESSIBLE ROUTES AND PATHS IN A BUILDING SHALL BE ACCESSIBLE... 1. ALL ACCESSIBLE ROUTES AND PATHS IN A BUILDING SHALL BE ACCESSIBLE... 2. ALL ACCESSIBLE ROUTES AND PATHS IN A BUILDING SHALL BE ACCESSIBLE...

STORAGE ACCESSIBILITY REQUIREMENTS THE INTERNATIONAL SYMBOL OF ACCESSIBILITY SHALL BE THE STANDARD DESIGN TO IDENTIFY RIGHTS IN THE FAIR AND SPECIFICALLY IDENTIFIED IN THE SECTION... 1. THE INTERNATIONAL SYMBOL OF ACCESSIBILITY SHALL BE THE STANDARD DESIGN TO IDENTIFY RIGHTS IN THE FAIR AND SPECIFICALLY IDENTIFIED IN THE SECTION...

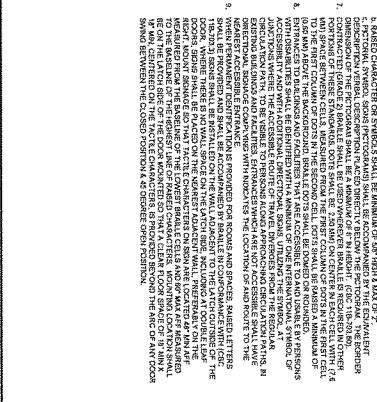

INTERNATIONAL TTY SYMBOL INTERNATIONAL TTY SYMBOL... 1. INTERNATIONAL TTY SYMBOL... 2. INTERNATIONAL TTY SYMBOL... 3. INTERNATIONAL TTY SYMBOL...

STORAGE ACCESSIBILITY REQUIREMENTS THE INTERNATIONAL SYMBOL OF ACCESSIBILITY SHALL BE THE STANDARD DESIGN TO IDENTIFY RIGHTS IN THE FAIR AND SPECIFICALLY IDENTIFIED IN THE SECTION... 1. THE INTERNATIONAL SYMBOL OF ACCESSIBILITY SHALL BE THE STANDARD DESIGN TO IDENTIFY RIGHTS IN THE FAIR AND SPECIFICALLY IDENTIFIED IN THE SECTION...

CLIENT: 411 E CHAPMAN AVE, PLACENTIA, CA 92679. PROJECT NAME: OUTDOOR LIBRARY. SHEET NO. 8 OF 33. ACCESSIBILITY DETAILS & NOTES. G-141

Attachment 88  
PLD 23X117.00  
PLACENTIA LIBRARY DISTRICT DESIGN SERVICES

CONTRACTOR SHALL BE RESPONSIBLE FOR OBTAINING ALL NECESSARY PERMITS FROM THE CITY ENGINEER'S OFFICE PRIOR TO THE COMMENCEMENT OF CONSTRUCTION. THE CONTRACTOR SHALL BE RESPONSIBLE FOR OBTAINING ALL NECESSARY PERMITS FROM THE CITY ENGINEER'S OFFICE PRIOR TO THE COMMENCEMENT OF CONSTRUCTION. THE CONTRACTOR SHALL BE RESPONSIBLE FOR OBTAINING ALL NECESSARY PERMITS FROM THE CITY ENGINEER'S OFFICE PRIOR TO THE COMMENCEMENT OF CONSTRUCTION.

STANDARD GRADING NOTES

- 1. GRADING SHALL BE IN ACCORDANCE WITH THE CITY ENGINEER'S STANDARD GRADING SPECIFICATIONS AND ANY APPLICABLE STANDARD SPECIFICATIONS FOR THE JURISDICTION. THE CONTRACTOR SHALL BE RESPONSIBLE FOR OBTAINING ALL NECESSARY PERMITS FROM THE CITY ENGINEER'S OFFICE PRIOR TO THE COMMENCEMENT OF CONSTRUCTION.
- 2. ALL GRADING SHALL BE ACCORDING TO THE CITY ENGINEER'S STANDARD GRADING SPECIFICATIONS AND ANY APPLICABLE STANDARD SPECIFICATIONS FOR THE JURISDICTION. THE CONTRACTOR SHALL BE RESPONSIBLE FOR OBTAINING ALL NECESSARY PERMITS FROM THE CITY ENGINEER'S OFFICE PRIOR TO THE COMMENCEMENT OF CONSTRUCTION.
- 3. ALL GRADING SHALL BE ACCORDING TO THE CITY ENGINEER'S STANDARD GRADING SPECIFICATIONS AND ANY APPLICABLE STANDARD SPECIFICATIONS FOR THE JURISDICTION. THE CONTRACTOR SHALL BE RESPONSIBLE FOR OBTAINING ALL NECESSARY PERMITS FROM THE CITY ENGINEER'S OFFICE PRIOR TO THE COMMENCEMENT OF CONSTRUCTION.

OUTDOOR LIBRARY IMPROVEMENT  
PLACENTIA LIBRARY  
CITY OF PLACENTIA

A FURTHER ENGINEERING CERTIFICATION AND FINAL CALCULATION REPORT MUST BE SUBMITTED TO AND APPROVED BY THE CITY ENGINEER PRIOR TO ISSUANCE OF ANY PERMITS. THE CONTRACTOR SHALL BE RESPONSIBLE FOR OBTAINING ALL NECESSARY PERMITS FROM THE CITY ENGINEER'S OFFICE PRIOR TO THE COMMENCEMENT OF CONSTRUCTION.

ABBREVIATIONS

B	BUILDING	E	EXISTING ELEVATION
C	CONCRETE	M	MAXIMUM
CC	CONCRETE CURB	MIN	MINIMUM
CP	CONCRETE PAVEMENT	MP	MEASUREMENT POINT
CP	CONCRETE PAVEMENT	MP	MEASUREMENT POINT
CP	CONCRETE PAVEMENT	MP	MEASUREMENT POINT

CONSTRUCTION NOTES

- 1. PROJECT SHALL BE CONSTRUCTED IN ACCORDANCE WITH THE CITY ENGINEER'S STANDARD SPECIFICATIONS AND ANY APPLICABLE STANDARD SPECIFICATIONS FOR THE JURISDICTION. THE CONTRACTOR SHALL BE RESPONSIBLE FOR OBTAINING ALL NECESSARY PERMITS FROM THE CITY ENGINEER'S OFFICE PRIOR TO THE COMMENCEMENT OF CONSTRUCTION.
- 2. ALL GRADING SHALL BE ACCORDING TO THE CITY ENGINEER'S STANDARD GRADING SPECIFICATIONS AND ANY APPLICABLE STANDARD SPECIFICATIONS FOR THE JURISDICTION. THE CONTRACTOR SHALL BE RESPONSIBLE FOR OBTAINING ALL NECESSARY PERMITS FROM THE CITY ENGINEER'S OFFICE PRIOR TO THE COMMENCEMENT OF CONSTRUCTION.
- 3. ALL GRADING SHALL BE ACCORDING TO THE CITY ENGINEER'S STANDARD GRADING SPECIFICATIONS AND ANY APPLICABLE STANDARD SPECIFICATIONS FOR THE JURISDICTION. THE CONTRACTOR SHALL BE RESPONSIBLE FOR OBTAINING ALL NECESSARY PERMITS FROM THE CITY ENGINEER'S OFFICE PRIOR TO THE COMMENCEMENT OF CONSTRUCTION.

EROSION CONTROL NOTES

- 1. EROSION CONTROL MEASURES SHALL BE INSTALLED AND MAINTAINED THROUGHOUT CONSTRUCTION TO PREVENT SOIL EROSION AND SEDIMENTATION. THE CONTRACTOR SHALL BE RESPONSIBLE FOR OBTAINING ALL NECESSARY PERMITS FROM THE CITY ENGINEER'S OFFICE PRIOR TO THE COMMENCEMENT OF CONSTRUCTION.
- 2. ALL EROSION CONTROL MEASURES SHALL BE INSTALLED AND MAINTAINED THROUGHOUT CONSTRUCTION TO PREVENT SOIL EROSION AND SEDIMENTATION. THE CONTRACTOR SHALL BE RESPONSIBLE FOR OBTAINING ALL NECESSARY PERMITS FROM THE CITY ENGINEER'S OFFICE PRIOR TO THE COMMENCEMENT OF CONSTRUCTION.
- 3. ALL EROSION CONTROL MEASURES SHALL BE INSTALLED AND MAINTAINED THROUGHOUT CONSTRUCTION TO PREVENT SOIL EROSION AND SEDIMENTATION. THE CONTRACTOR SHALL BE RESPONSIBLE FOR OBTAINING ALL NECESSARY PERMITS FROM THE CITY ENGINEER'S OFFICE PRIOR TO THE COMMENCEMENT OF CONSTRUCTION.

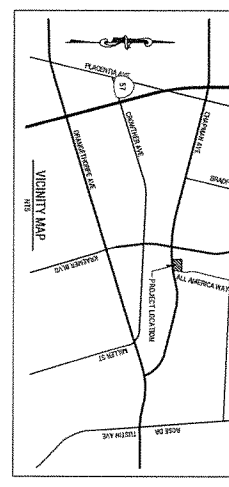

CREDIT LOG AND ADDRESS MAP  
411 E CHAMPAINE AVE  
PLACENTIA, CA 92679

OUTDOOR LIBRARY  
PROJECT NAME

411 E CHAMPAINE AVE  
PLACENTIA, CA 92679

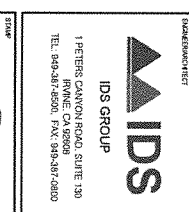

1 PETERSON CANYON ROAD, SUITE 130  
IRVINE, CA 92618  
TEL: 949.837.8500, FAX: 949.837.6400

REV	DESCRIPTION	DATE
01	PLAN CHECK SUBMITTAL	05/24/23
02	PLACENTIA SUBMITTAL	06/04/23

PROJECT IDENTIFICATION  
PROJECT NAME: OUTDOOR LIBRARY IMPROVEMENT  
PROJECT NO.: 23X117.00  
DRAWN BY: HN  
CHECKED BY: AS

GENERAL NOTES  
SHEET NO. 13 OF 53

APPROVAL:  
DESIGNER: HARRY NGUYEN  
DATE: 02/20/24

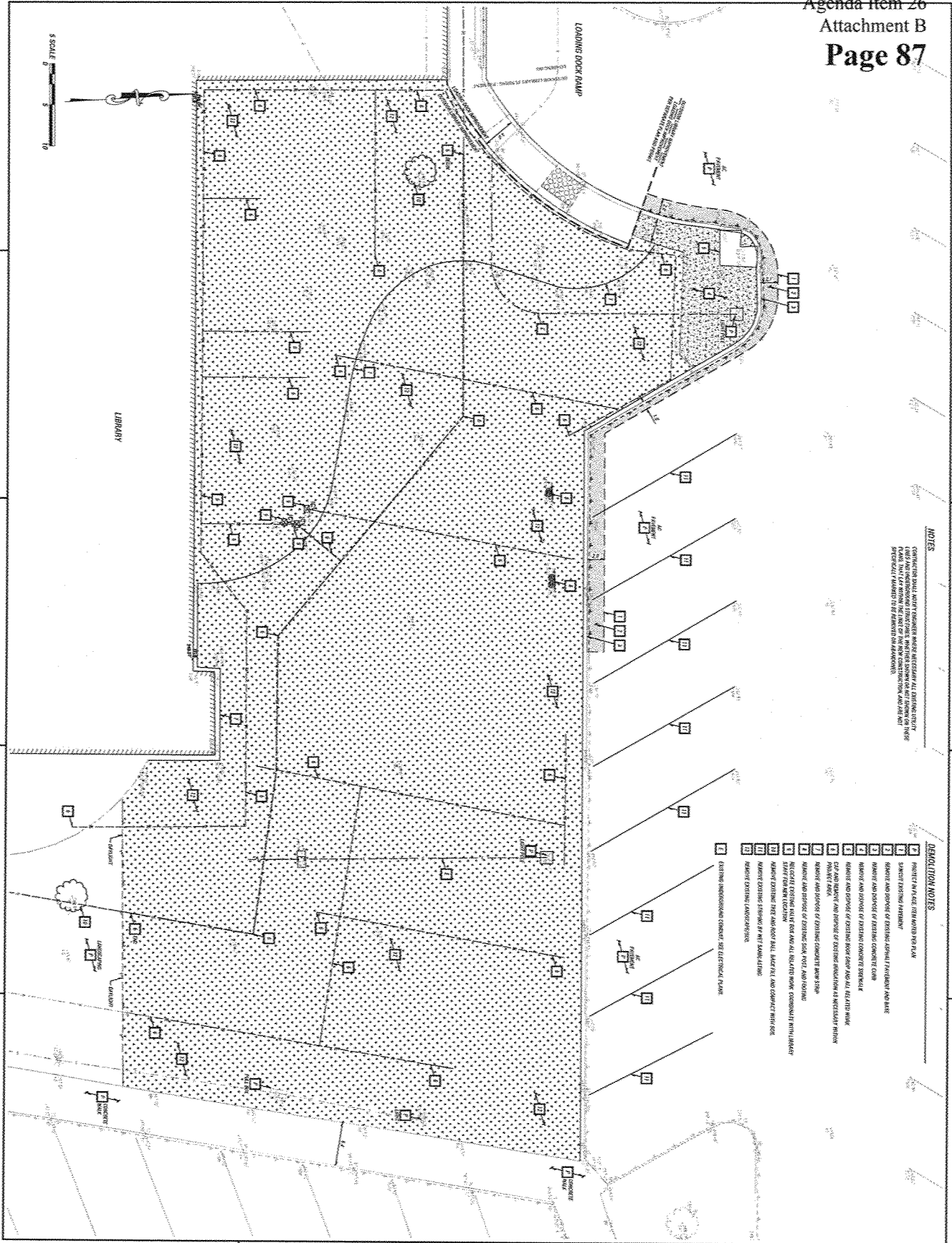

**NOTES**

1. CONSULTATION SHALL BE REQUIRED FOR ALL DEMOLITION. ALL DEMOLITION SHALL BE IN ACCORDANCE WITH THE CALIFORNIA DEMOLITION ACT AND ALL APPLICABLE REGULATIONS. DEMOLITION SHALL BE IN ACCORDANCE WITH THE CALIFORNIA DEMOLITION ACT AND ALL APPLICABLE REGULATIONS.

**DEMOLITION NOTES**

- 1. REMOVE EXISTING CONCRETE AND BRICK WALLS AND FOUNDATION.
- 2. REMOVE EXISTING ROOFING.
- 3. REMOVE AND DISPOSE OF EXISTING CONCRETE FOUNDATION AND BRICK WALLS.
- 4. REMOVE AND DISPOSE OF EXISTING CONCRETE FOUNDATION AND BRICK WALLS.
- 5. REMOVE AND DISPOSE OF EXISTING CONCRETE FOUNDATION AND BRICK WALLS.
- 6. REMOVE AND DISPOSE OF EXISTING CONCRETE FOUNDATION AND BRICK WALLS.
- 7. REMOVE AND DISPOSE OF EXISTING CONCRETE FOUNDATION AND BRICK WALLS.
- 8. REMOVE AND DISPOSE OF EXISTING CONCRETE FOUNDATION AND BRICK WALLS.
- 9. REMOVE AND DISPOSE OF EXISTING CONCRETE FOUNDATION AND BRICK WALLS.
- 10. REMOVE AND DISPOSE OF EXISTING CONCRETE FOUNDATION AND BRICK WALLS.
- 11. REMOVE EXISTING CONCRETE FOUNDATION AND BRICK WALLS.
- 12. REMOVE EXISTING CONCRETE FOUNDATION AND BRICK WALLS.
- 13. REMOVE EXISTING CONCRETE FOUNDATION AND BRICK WALLS.
- 14. REMOVE EXISTING CONCRETE FOUNDATION AND BRICK WALLS.
- 15. REMOVE EXISTING CONCRETE FOUNDATION AND BRICK WALLS.
- 16. REMOVE EXISTING CONCRETE FOUNDATION AND BRICK WALLS.
- 17. REMOVE EXISTING CONCRETE FOUNDATION AND BRICK WALLS.
- 18. REMOVE EXISTING CONCRETE FOUNDATION AND BRICK WALLS.
- 19. REMOVE EXISTING CONCRETE FOUNDATION AND BRICK WALLS.
- 20. REMOVE EXISTING CONCRETE FOUNDATION AND BRICK WALLS.
- 21. REMOVE EXISTING CONCRETE FOUNDATION AND BRICK WALLS.
- 22. REMOVE EXISTING CONCRETE FOUNDATION AND BRICK WALLS.
- 23. REMOVE EXISTING CONCRETE FOUNDATION AND BRICK WALLS.
- 24. REMOVE EXISTING CONCRETE FOUNDATION AND BRICK WALLS.
- 25. REMOVE EXISTING CONCRETE FOUNDATION AND BRICK WALLS.
- 26. REMOVE EXISTING CONCRETE FOUNDATION AND BRICK WALLS.
- 27. REMOVE EXISTING CONCRETE FOUNDATION AND BRICK WALLS.
- 28. REMOVE EXISTING CONCRETE FOUNDATION AND BRICK WALLS.
- 29. REMOVE EXISTING CONCRETE FOUNDATION AND BRICK WALLS.
- 30. REMOVE EXISTING CONCRETE FOUNDATION AND BRICK WALLS.
- 31. REMOVE EXISTING CONCRETE FOUNDATION AND BRICK WALLS.
- 32. REMOVE EXISTING CONCRETE FOUNDATION AND BRICK WALLS.
- 33. REMOVE EXISTING CONCRETE FOUNDATION AND BRICK WALLS.
- 34. REMOVE EXISTING CONCRETE FOUNDATION AND BRICK WALLS.
- 35. REMOVE EXISTING CONCRETE FOUNDATION AND BRICK WALLS.
- 36. REMOVE EXISTING CONCRETE FOUNDATION AND BRICK WALLS.
- 37. REMOVE EXISTING CONCRETE FOUNDATION AND BRICK WALLS.
- 38. REMOVE EXISTING CONCRETE FOUNDATION AND BRICK WALLS.
- 39. REMOVE EXISTING CONCRETE FOUNDATION AND BRICK WALLS.
- 40. REMOVE EXISTING CONCRETE FOUNDATION AND BRICK WALLS.
- 41. REMOVE EXISTING CONCRETE FOUNDATION AND BRICK WALLS.
- 42. REMOVE EXISTING CONCRETE FOUNDATION AND BRICK WALLS.
- 43. REMOVE EXISTING CONCRETE FOUNDATION AND BRICK WALLS.
- 44. REMOVE EXISTING CONCRETE FOUNDATION AND BRICK WALLS.
- 45. REMOVE EXISTING CONCRETE FOUNDATION AND BRICK WALLS.
- 46. REMOVE EXISTING CONCRETE FOUNDATION AND BRICK WALLS.
- 47. REMOVE EXISTING CONCRETE FOUNDATION AND BRICK WALLS.
- 48. REMOVE EXISTING CONCRETE FOUNDATION AND BRICK WALLS.
- 49. REMOVE EXISTING CONCRETE FOUNDATION AND BRICK WALLS.
- 50. REMOVE EXISTING CONCRETE FOUNDATION AND BRICK WALLS.
- 51. REMOVE EXISTING CONCRETE FOUNDATION AND BRICK WALLS.
- 52. REMOVE EXISTING CONCRETE FOUNDATION AND BRICK WALLS.
- 53. REMOVE EXISTING CONCRETE FOUNDATION AND BRICK WALLS.
- 54. REMOVE EXISTING CONCRETE FOUNDATION AND BRICK WALLS.
- 55. REMOVE EXISTING CONCRETE FOUNDATION AND BRICK WALLS.
- 56. REMOVE EXISTING CONCRETE FOUNDATION AND BRICK WALLS.
- 57. REMOVE EXISTING CONCRETE FOUNDATION AND BRICK WALLS.
- 58. REMOVE EXISTING CONCRETE FOUNDATION AND BRICK WALLS.
- 59. REMOVE EXISTING CONCRETE FOUNDATION AND BRICK WALLS.
- 60. REMOVE EXISTING CONCRETE FOUNDATION AND BRICK WALLS.
- 61. REMOVE EXISTING CONCRETE FOUNDATION AND BRICK WALLS.
- 62. REMOVE EXISTING CONCRETE FOUNDATION AND BRICK WALLS.
- 63. REMOVE EXISTING CONCRETE FOUNDATION AND BRICK WALLS.
- 64. REMOVE EXISTING CONCRETE FOUNDATION AND BRICK WALLS.
- 65. REMOVE EXISTING CONCRETE FOUNDATION AND BRICK WALLS.
- 66. REMOVE EXISTING CONCRETE FOUNDATION AND BRICK WALLS.
- 67. REMOVE EXISTING CONCRETE FOUNDATION AND BRICK WALLS.
- 68. REMOVE EXISTING CONCRETE FOUNDATION AND BRICK WALLS.
- 69. REMOVE EXISTING CONCRETE FOUNDATION AND BRICK WALLS.
- 70. REMOVE EXISTING CONCRETE FOUNDATION AND BRICK WALLS.
- 71. REMOVE EXISTING CONCRETE FOUNDATION AND BRICK WALLS.
- 72. REMOVE EXISTING CONCRETE FOUNDATION AND BRICK WALLS.
- 73. REMOVE EXISTING CONCRETE FOUNDATION AND BRICK WALLS.
- 74. REMOVE EXISTING CONCRETE FOUNDATION AND BRICK WALLS.
- 75. REMOVE EXISTING CONCRETE FOUNDATION AND BRICK WALLS.
- 76. REMOVE EXISTING CONCRETE FOUNDATION AND BRICK WALLS.
- 77. REMOVE EXISTING CONCRETE FOUNDATION AND BRICK WALLS.
- 78. REMOVE EXISTING CONCRETE FOUNDATION AND BRICK WALLS.
- 79. REMOVE EXISTING CONCRETE FOUNDATION AND BRICK WALLS.
- 80. REMOVE EXISTING CONCRETE FOUNDATION AND BRICK WALLS.
- 81. REMOVE EXISTING CONCRETE FOUNDATION AND BRICK WALLS.
- 82. REMOVE EXISTING CONCRETE FOUNDATION AND BRICK WALLS.
- 83. REMOVE EXISTING CONCRETE FOUNDATION AND BRICK WALLS.
- 84. REMOVE EXISTING CONCRETE FOUNDATION AND BRICK WALLS.
- 85. REMOVE EXISTING CONCRETE FOUNDATION AND BRICK WALLS.
- 86. REMOVE EXISTING CONCRETE FOUNDATION AND BRICK WALLS.
- 87. REMOVE EXISTING CONCRETE FOUNDATION AND BRICK WALLS.
- 88. REMOVE EXISTING CONCRETE FOUNDATION AND BRICK WALLS.
- 89. REMOVE EXISTING CONCRETE FOUNDATION AND BRICK WALLS.
- 90. REMOVE EXISTING CONCRETE FOUNDATION AND BRICK WALLS.
- 91. REMOVE EXISTING CONCRETE FOUNDATION AND BRICK WALLS.
- 92. REMOVE EXISTING CONCRETE FOUNDATION AND BRICK WALLS.
- 93. REMOVE EXISTING CONCRETE FOUNDATION AND BRICK WALLS.
- 94. REMOVE EXISTING CONCRETE FOUNDATION AND BRICK WALLS.
- 95. REMOVE EXISTING CONCRETE FOUNDATION AND BRICK WALLS.
- 96. REMOVE EXISTING CONCRETE FOUNDATION AND BRICK WALLS.
- 97. REMOVE EXISTING CONCRETE FOUNDATION AND BRICK WALLS.
- 98. REMOVE EXISTING CONCRETE FOUNDATION AND BRICK WALLS.
- 99. REMOVE EXISTING CONCRETE FOUNDATION AND BRICK WALLS.
- 100. REMOVE EXISTING CONCRETE FOUNDATION AND BRICK WALLS.

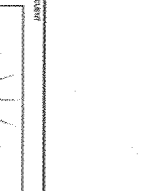
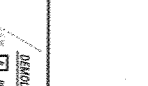
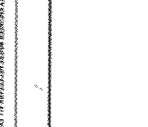
 CITY OF PLACENTIA 411 E. CHAPMAN AVE. PLACENTIA, CA 92679	<b>OUTDOOR LIBRARY</b>	 IDS GROUP 1 PETERSON AVENUE, SUITE 100 IRVINE, CA 92618 TEL: 949.261.8800 FAX: 949.261.8802	 HARRY NGUYEN CIVIL ENGINEER No. 10000	PROJECT NUMBER: <b>C-100</b>	SHEET NO. 14 OF 33
--	------------------------	---	---	---------------------------------	--------------------















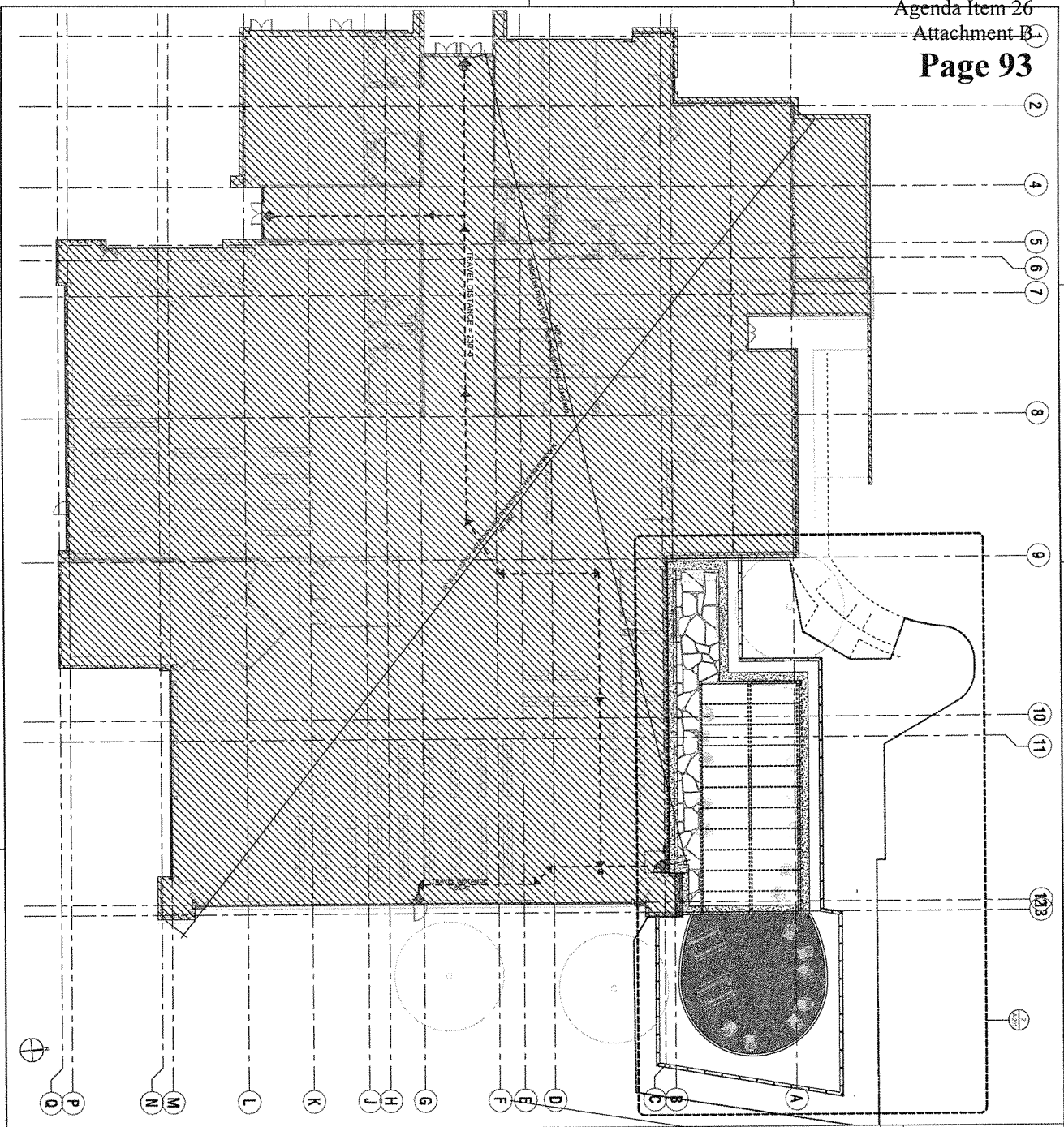

**CODE REQUIREMENTS**

**MINIMUM CLEARANCE**  
 MINIMUM CLEARANCE BETWEEN EXITS FOR  
 SPRINKLER SYSTEM BUILDING CODE 2022 1017.2.2.2  
**EXIT OCCUPANCY**  
 EXIT OCCUPANCY TABLE 1009 OCCUPANCY  
 MAXIMUM DISTANCE BETWEEN EXITS FOR  
 SPRINKLER SYSTEM BUILDING CODE 2022 1017.2.2.2  
 EXIT TABLE 1017.2 FOR ALL OCCUPANCY - 200'0"

**LEGEND**

- REPORTS 44' UNACCESSIBLE PATH OF TRAVEL
- REPORTS EXISTING ROUTE DIRECTION
- UNLIMITED EXIT SIGN
- NOT IN CONTACT (NFC)
- UNIT OF WORK
- REQUIRED CLEARANCE
- SEE PLAN
- PROSPECTIVE USE REFER TO ARCHITECT'S RESPONSE ONLY

**REFERENCES**

FOR EXISTING BUILDING OCCUPANCY AND PLUMBING  
 SYSTEM CALCULATIONS PLEASE REFER TO DOCUMENT  
 NUMBERED 23X117.00 SHEET 100



PROJECT NAME  
**OUTDOOR LIBRARY**  
 411 E. CHAPMAN AVE.  
 PLACENTIA, CA 92670

**IDS GROUP**  
 1 PETERS CANYON ROAD, SUITE 130  
 IRVINE, CA 92618  
 TEL: 949.459.4591 FAX: 949.317.4890



NO.	DATE	REVISION
1	08/20/24	FINAL CHECK SUBMITTAL
2	08/20/24	FOR CHECK SUBMITTAL

**PROJECT IDENTIFICATION**  
 PROJECT NAME: OUTDOOR LIBRARY  
 PROJECT NO.: 23X117.00  
 SHEET NO.: G-120 OF 53

**DESIGNER**  
 DESIGNER: IDS GROUP  
 CHECKED BY: [Signature]  
 APPROVED BY: [Signature]

**CLIENT**  
 CLIENT: PLACENTIA LIBRARY DISTRICT

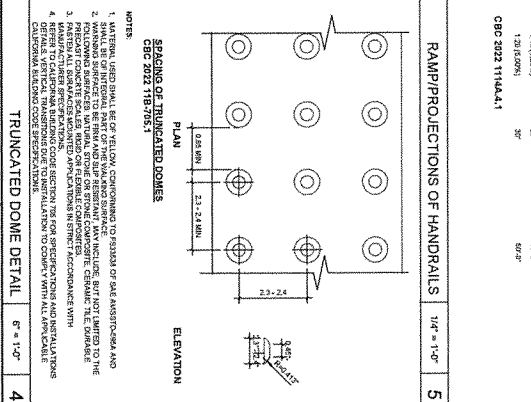
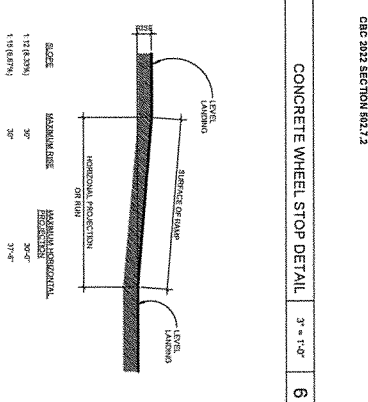
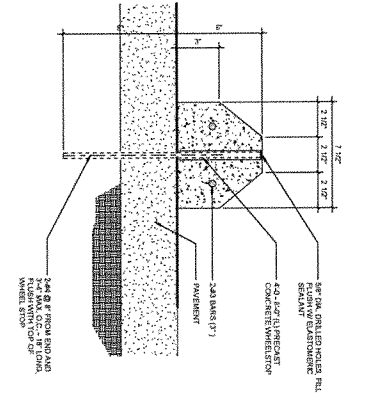
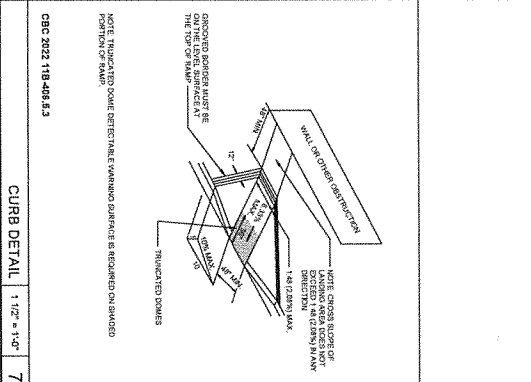
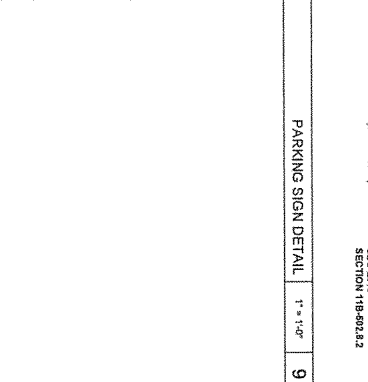
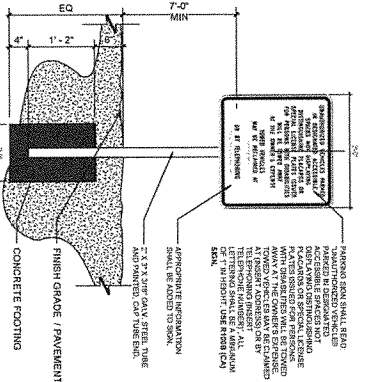
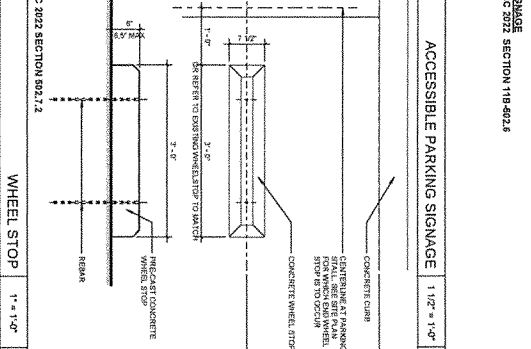
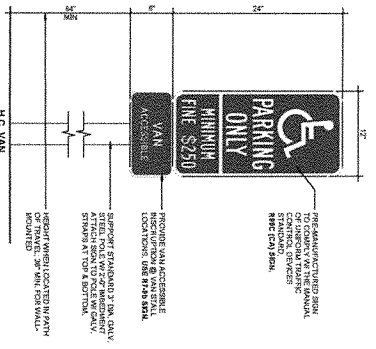
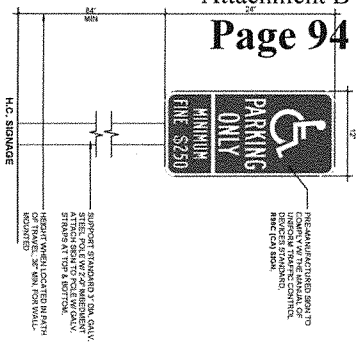

**SITE ACCESS NOTES**

**GENERAL**

- ALL NEW AND EXISTING DRIVEWAYS AND DRIVEWAYS SHALL BE CONSTRUCTED TO ACCOMMODATE THE MINIMUM SIGNIFICANT CONTRAST REQUIREMENTS.
- ALL NEW AND EXISTING DRIVEWAYS AND DRIVEWAYS SHALL BE CONSTRUCTED TO ACCOMMODATE THE MINIMUM SIGNIFICANT CONTRAST REQUIREMENTS.
- ALL NEW AND EXISTING DRIVEWAYS AND DRIVEWAYS SHALL BE CONSTRUCTED TO ACCOMMODATE THE MINIMUM SIGNIFICANT CONTRAST REQUIREMENTS.

**ADA STANDARDS**

- 2010 ADA STANDARDS FOR ACCESSIBLE BUILDINGS AND ELEMENTS (2010 ADA STANDARDS) SHALL BE USED.
- 2010 ADA STANDARDS FOR ACCESSIBLE BUILDINGS AND ELEMENTS (2010 ADA STANDARDS) SHALL BE USED.
- 2010 ADA STANDARDS FOR ACCESSIBLE BUILDINGS AND ELEMENTS (2010 ADA STANDARDS) SHALL BE USED.

**REMARKS**

- ALL NEW AND EXISTING DRIVEWAYS AND DRIVEWAYS SHALL BE CONSTRUCTED TO ACCOMMODATE THE MINIMUM SIGNIFICANT CONTRAST REQUIREMENTS.
- ALL NEW AND EXISTING DRIVEWAYS AND DRIVEWAYS SHALL BE CONSTRUCTED TO ACCOMMODATE THE MINIMUM SIGNIFICANT CONTRAST REQUIREMENTS.
- ALL NEW AND EXISTING DRIVEWAYS AND DRIVEWAYS SHALL BE CONSTRUCTED TO ACCOMMODATE THE MINIMUM SIGNIFICANT CONTRAST REQUIREMENTS.

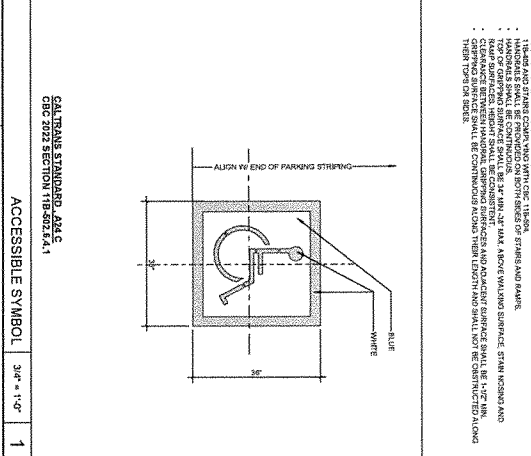

**placentia**  
LIBRARY DISTRICT

CLIENT LOGO AND ADDRESS: 411 E. CHAPMAN AVE., PLACENTIA, CA 92770

**OUTDOOR LIBRARY**

411 E. CHAPMAN AVE.  
PLACENTIA, CA 92770

**IDS GROUP**

1 PETERS CANYON ROAD, SUITE 130  
IRVINE, CA 92618  
TEL: 949-357-4500, FAX: 949-357-0850

**PROJECT IDENTIFICATION**

PROJECT NO. 23X117.00  
DRAWN BY: Andrew  
CHECKED BY: Andrew  
APPROVED BY: Andrew

**ADA SITE AND PARKING DETAILS**

SHEET NO. 7 OF 53

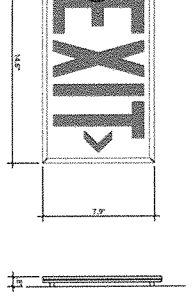

TACTILE EXIT SIGN



EXIT ROUTE SIGN

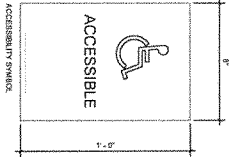

ACCESSIBILITY SYMBOL

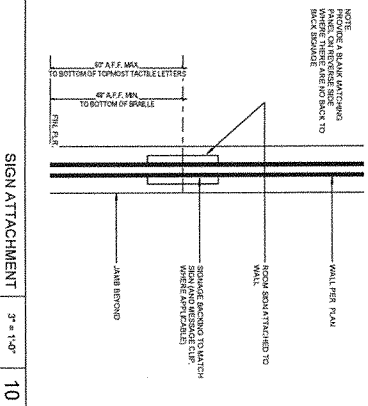

1. FROM BOTTOM, TO BE UNMATCHED AT THE TOP EDGE; THE BOTTOM LETTERS  
2. LOWER SECTION, OR LOWER SECTION FROM THE SIGN  
3. THE SIGN SHOULD BE MOUNTED TO THE WALL AT A MINIMUM HEIGHT OF 4' 0" TO  
4. THE SIGN SHOULD BE MOUNTED TO THE WALL AT A MINIMUM HEIGHT OF 4' 0" TO  
5. THE SIGN SHOULD BE MOUNTED TO THE WALL AT A MINIMUM HEIGHT OF 4' 0" TO

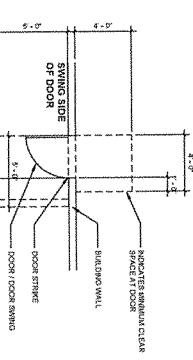

MINIMUM REQUIRED DOOR CLEARANCE

INTERIOR OR EXTERIOR DOOR - A LEVEL AND CLEAR FLOOR OR  
FLOORING ON EACH SIDE OF DOOR IN THE DIRECTION OF DOOR SWING  
OR AT LEAST 4' 0" AND THE LENGTH OPPOSITE THE DIRECTION OF DOOR  
SWING OF 4' 0" AT DOORS WITH AUTOMATIC CLOSURES AS MEASURED  
POSITIONS ARE 11A-901.1-11A-901.2.4

DOOR CLEARANCE

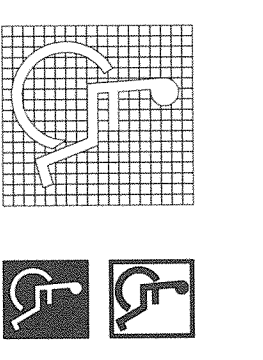

PROPORTIONS



DISPLAY CONDITIONS

INTERNATIONAL ACCESSIBILITY SYMBOL  
11  
INTERNATIONAL TTY SYMBOL  
10  
ACCESS INTL SYM FOR HEARING LOSS  
N.T.S.  
7

INTERNATIONAL TTY SYMBOL  
CBC 2022 FIGURE 11B-03.7.2.2  
INTERNATIONAL TTY SYMBOL FOR HEARING LOSS  
CBC 2022 FIGURE 11B-03.7.2.4

PATH OF TRAVEL SIGNAGE AND ACCESS

**BUILDING ACCESS**

- ALL PRIMARY ENTRANCES TO BE ACCESSIBLE
- SIGNAGE PROVIDED AT STRIKE SET OF UNCOMBINED EXTERIOR DOORS 3'6"
- LEVEL SPACE AT RECESSED EXTERIOR DOORS
- LEVEL SPACE AT RECESSED EXTERIOR DOORS
- LEVEL SPACE AT RECESSED EXTERIOR DOORS
- LEVEL SPACE AT RECESSED EXTERIOR DOORS
- LEVEL SPACE AT RECESSED EXTERIOR DOORS
- LEVEL SPACE AT RECESSED EXTERIOR DOORS

**PATH OF TRAVEL AND ACCESSIBLE ROUTE**

- 1. ACCESSIBLE ROUTE OF TRAVEL IS DEFINED AS A CONTINUOUS UNINTERRUPTED PATH CONNECTING
- 2. ACCESSIBLE ROUTE OF TRAVEL IS DEFINED AS A CONTINUOUS UNINTERRUPTED PATH CONNECTING
- 3. ACCESSIBLE ROUTE OF TRAVEL IS DEFINED AS A CONTINUOUS UNINTERRUPTED PATH CONNECTING
- 4. ACCESSIBLE ROUTE OF TRAVEL IS DEFINED AS A CONTINUOUS UNINTERRUPTED PATH CONNECTING
- 5. ACCESSIBLE ROUTE OF TRAVEL IS DEFINED AS A CONTINUOUS UNINTERRUPTED PATH CONNECTING

**SIGNAGE, DOORS AND DOORWAYS**

- 1. ACCESSIBLE ROUTE OF TRAVEL IS DEFINED AS A CONTINUOUS UNINTERRUPTED PATH CONNECTING
- 2. ACCESSIBLE ROUTE OF TRAVEL IS DEFINED AS A CONTINUOUS UNINTERRUPTED PATH CONNECTING
- 3. ACCESSIBLE ROUTE OF TRAVEL IS DEFINED AS A CONTINUOUS UNINTERRUPTED PATH CONNECTING
- 4. ACCESSIBLE ROUTE OF TRAVEL IS DEFINED AS A CONTINUOUS UNINTERRUPTED PATH CONNECTING
- 5. ACCESSIBLE ROUTE OF TRAVEL IS DEFINED AS A CONTINUOUS UNINTERRUPTED PATH CONNECTING

**ENTRANCE AND EXITS**

- 1. EXIT AND ENTRANCE IS A CONTINUOUS UNINTERRUPTED PATH OF ENTRY TO A PUBLIC WAY AND
- 2. EXIT AND ENTRANCE IS A CONTINUOUS UNINTERRUPTED PATH OF ENTRY TO A PUBLIC WAY AND
- 3. EXIT AND ENTRANCE IS A CONTINUOUS UNINTERRUPTED PATH OF ENTRY TO A PUBLIC WAY AND
- 4. EXIT AND ENTRANCE IS A CONTINUOUS UNINTERRUPTED PATH OF ENTRY TO A PUBLIC WAY AND
- 5. EXIT AND ENTRANCE IS A CONTINUOUS UNINTERRUPTED PATH OF ENTRY TO A PUBLIC WAY AND

NO.	REV.	DESCRIPTION	DATE
	1	PLAN CHECK SUBMITTAL	08/20/24
	2	PLAN CHECK SUBMITTAL	08/20/24
	3	PLAN CHECK SUBMITTAL	08/20/24

PROJECT IDENTIFICATION  
PROJECT NO. 23X117.00  
SHEET NO. 9 OF 35  
G-141

**placentia**  
LIBRARY DISTRICT  
411 E CHAPMAN AVE.  
PLACENTIA, CA 92669  
TEL: 949.981.8501 FAX: 949.981.9490

**IDS GROUP**  
1 PETERS CANYON ROAD SUITE 130  
PLACENTIA, CA 92669  
TEL: 949.981.8501 FAX: 949.981.9490



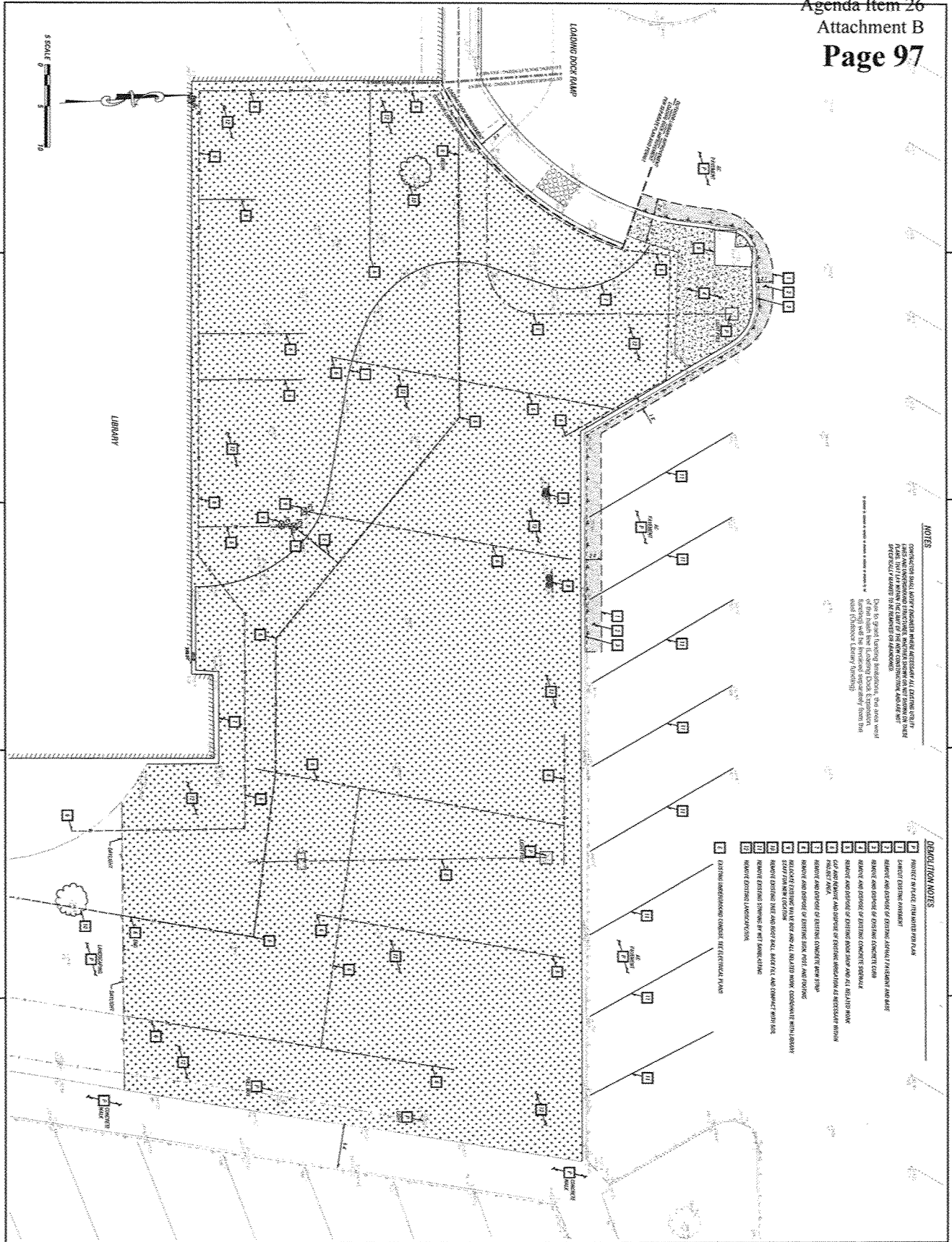



**NOTES**

CONSTRUCTION SHALL VERIFY CONDITIONS BEFORE PROCEEDING WITH ALL CONSTRUCTION. THE CONTRACTOR SHALL BE RESPONSIBLE FOR VERIFYING THE EXISTING CONDITIONS AND SHALL BE RESPONSIBLE FOR CORRECTING ANY DEFICIENCIES. THE CONTRACTOR SHALL BE RESPONSIBLE FOR OBTAINING ALL NECESSARY PERMITS AND APPROVALS FROM THE CITY OF PLACENTIA AND THE CALIFORNIA LIBRARY DISTRICT.

Due to special building conditions, the area west of the main level Loading Dock Expansion (Loading) will be excavated separately from the west (Existing Library) building.

- DEMOLITION NOTES**
- 1. REMOVE EXISTING CONCRETE
  - 2. REMOVE AND DISPOSE OF EXISTING CONCRETE
  - 3. REMOVE AND DISPOSE OF EXISTING CONCRETE
  - 4. REMOVE AND DISPOSE OF EXISTING CONCRETE
  - 5. REMOVE AND DISPOSE OF EXISTING CONCRETE
  - 6. REMOVE AND DISPOSE OF EXISTING CONCRETE
  - 7. REMOVE AND DISPOSE OF EXISTING CONCRETE
  - 8. REMOVE AND DISPOSE OF EXISTING CONCRETE
  - 9. REMOVE AND DISPOSE OF EXISTING CONCRETE
  - 10. REMOVE AND DISPOSE OF EXISTING CONCRETE
  - 11. REMOVE AND DISPOSE OF EXISTING CONCRETE
  - 12. REMOVE AND DISPOSE OF EXISTING CONCRETE
  - 13. REMOVE AND DISPOSE OF EXISTING CONCRETE
  - 14. REMOVE AND DISPOSE OF EXISTING CONCRETE
  - 15. REMOVE AND DISPOSE OF EXISTING CONCRETE
  - 16. REMOVE AND DISPOSE OF EXISTING CONCRETE
  - 17. REMOVE AND DISPOSE OF EXISTING CONCRETE
  - 18. REMOVE AND DISPOSE OF EXISTING CONCRETE
  - 19. REMOVE AND DISPOSE OF EXISTING CONCRETE
  - 20. REMOVE AND DISPOSE OF EXISTING CONCRETE
  - 21. REMOVE AND DISPOSE OF EXISTING CONCRETE
  - 22. REMOVE AND DISPOSE OF EXISTING CONCRETE
  - 23. REMOVE AND DISPOSE OF EXISTING CONCRETE
  - 24. REMOVE AND DISPOSE OF EXISTING CONCRETE
  - 25. REMOVE AND DISPOSE OF EXISTING CONCRETE
  - 26. REMOVE AND DISPOSE OF EXISTING CONCRETE
  - 27. REMOVE AND DISPOSE OF EXISTING CONCRETE
  - 28. REMOVE AND DISPOSE OF EXISTING CONCRETE
  - 29. REMOVE AND DISPOSE OF EXISTING CONCRETE
  - 30. REMOVE AND DISPOSE OF EXISTING CONCRETE
  - 31. REMOVE AND DISPOSE OF EXISTING CONCRETE
  - 32. REMOVE AND DISPOSE OF EXISTING CONCRETE
  - 33. REMOVE AND DISPOSE OF EXISTING CONCRETE
  - 34. REMOVE AND DISPOSE OF EXISTING CONCRETE
  - 35. REMOVE AND DISPOSE OF EXISTING CONCRETE
  - 36. REMOVE AND DISPOSE OF EXISTING CONCRETE
  - 37. REMOVE AND DISPOSE OF EXISTING CONCRETE
  - 38. REMOVE AND DISPOSE OF EXISTING CONCRETE
  - 39. REMOVE AND DISPOSE OF EXISTING CONCRETE
  - 40. REMOVE AND DISPOSE OF EXISTING CONCRETE
  - 41. REMOVE AND DISPOSE OF EXISTING CONCRETE
  - 42. REMOVE AND DISPOSE OF EXISTING CONCRETE
  - 43. REMOVE AND DISPOSE OF EXISTING CONCRETE
  - 44. REMOVE AND DISPOSE OF EXISTING CONCRETE
  - 45. REMOVE AND DISPOSE OF EXISTING CONCRETE
  - 46. REMOVE AND DISPOSE OF EXISTING CONCRETE
  - 47. REMOVE AND DISPOSE OF EXISTING CONCRETE
  - 48. REMOVE AND DISPOSE OF EXISTING CONCRETE
  - 49. REMOVE AND DISPOSE OF EXISTING CONCRETE
  - 50. REMOVE AND DISPOSE OF EXISTING CONCRETE
  - 51. REMOVE AND DISPOSE OF EXISTING CONCRETE
  - 52. REMOVE AND DISPOSE OF EXISTING CONCRETE
  - 53. REMOVE AND DISPOSE OF EXISTING CONCRETE
  - 54. REMOVE AND DISPOSE OF EXISTING CONCRETE
  - 55. REMOVE AND DISPOSE OF EXISTING CONCRETE
  - 56. REMOVE AND DISPOSE OF EXISTING CONCRETE
  - 57. REMOVE AND DISPOSE OF EXISTING CONCRETE
  - 58. REMOVE AND DISPOSE OF EXISTING CONCRETE
  - 59. REMOVE AND DISPOSE OF EXISTING CONCRETE
  - 60. REMOVE AND DISPOSE OF EXISTING CONCRETE
  - 61. REMOVE AND DISPOSE OF EXISTING CONCRETE
  - 62. REMOVE AND DISPOSE OF EXISTING CONCRETE
  - 63. REMOVE AND DISPOSE OF EXISTING CONCRETE
  - 64. REMOVE AND DISPOSE OF EXISTING CONCRETE
  - 65. REMOVE AND DISPOSE OF EXISTING CONCRETE
  - 66. REMOVE AND DISPOSE OF EXISTING CONCRETE
  - 67. REMOVE AND DISPOSE OF EXISTING CONCRETE
  - 68. REMOVE AND DISPOSE OF EXISTING CONCRETE
  - 69. REMOVE AND DISPOSE OF EXISTING CONCRETE
  - 70. REMOVE AND DISPOSE OF EXISTING CONCRETE
  - 71. REMOVE AND DISPOSE OF EXISTING CONCRETE
  - 72. REMOVE AND DISPOSE OF EXISTING CONCRETE
  - 73. REMOVE AND DISPOSE OF EXISTING CONCRETE
  - 74. REMOVE AND DISPOSE OF EXISTING CONCRETE
  - 75. REMOVE AND DISPOSE OF EXISTING CONCRETE
  - 76. REMOVE AND DISPOSE OF EXISTING CONCRETE
  - 77. REMOVE AND DISPOSE OF EXISTING CONCRETE
  - 78. REMOVE AND DISPOSE OF EXISTING CONCRETE
  - 79. REMOVE AND DISPOSE OF EXISTING CONCRETE
  - 80. REMOVE AND DISPOSE OF EXISTING CONCRETE
  - 81. REMOVE AND DISPOSE OF EXISTING CONCRETE
  - 82. REMOVE AND DISPOSE OF EXISTING CONCRETE
  - 83. REMOVE AND DISPOSE OF EXISTING CONCRETE
  - 84. REMOVE AND DISPOSE OF EXISTING CONCRETE
  - 85. REMOVE AND DISPOSE OF EXISTING CONCRETE
  - 86. REMOVE AND DISPOSE OF EXISTING CONCRETE
  - 87. REMOVE AND DISPOSE OF EXISTING CONCRETE
  - 88. REMOVE AND DISPOSE OF EXISTING CONCRETE
  - 89. REMOVE AND DISPOSE OF EXISTING CONCRETE
  - 90. REMOVE AND DISPOSE OF EXISTING CONCRETE
  - 91. REMOVE AND DISPOSE OF EXISTING CONCRETE
  - 92. REMOVE AND DISPOSE OF EXISTING CONCRETE
  - 93. REMOVE AND DISPOSE OF EXISTING CONCRETE
  - 94. REMOVE AND DISPOSE OF EXISTING CONCRETE
  - 95. REMOVE AND DISPOSE OF EXISTING CONCRETE
  - 96. REMOVE AND DISPOSE OF EXISTING CONCRETE
  - 97. REMOVE AND DISPOSE OF EXISTING CONCRETE
  - 98. REMOVE AND DISPOSE OF EXISTING CONCRETE
  - 99. REMOVE AND DISPOSE OF EXISTING CONCRETE
  - 100. REMOVE AND DISPOSE OF EXISTING CONCRETE

 <p><b>placentia</b> LIBRARY DISTRICT</p>	<p>411 E. GARDEN AVE PLACENTIA, CA 92870</p> <p><b>OUTDOOR LIBRARY</b></p>	<p><b>MIDS</b> IDS GROUP</p> <p>1 PETERSON CAMPUS BLVD, SUITE 100 IRVINE, CA 92618 TEL: 949-361-4800 FAX: 949-361-4800</p>		<p><b>PROJECT IDENTIFICATION</b></p> <p>PROJECT NO. 23X117.00</p> <p>SHEET NO. 14 OF 33</p>	<p><b>DEMOLITION PLANS</b></p> <p>SHEET NO. 14 OF 33</p>
--	--	--	---	---	--



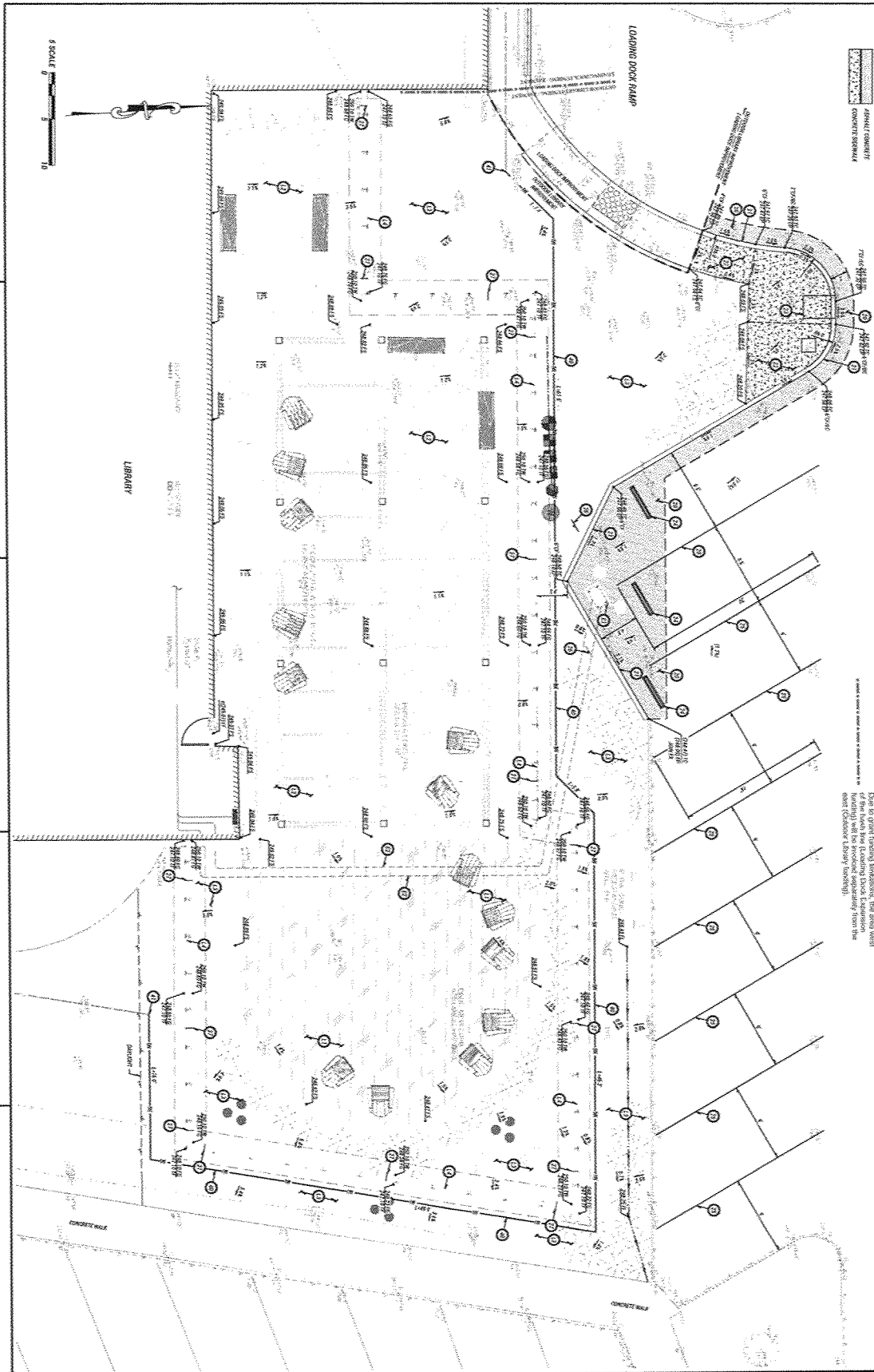



- LEGEND**
- 1" = 1' CONCRETE
  - 1" = 1' PAVING
  - 1" = 1' LANDSCAPE
  - 1" = 1' CONCRETE
  - 1" = 1' PAVING
  - 1" = 1' LANDSCAPE
  - 1" = 1' CONCRETE
  - 1" = 1' PAVING
  - 1" = 1' LANDSCAPE

- COORDINATION NOTES**
1. DATE VENDOR RESPONSE RETURN AND BUILDING ELECTRICAL PLANS
  2. CONDUCT PRELIMINARY MEETING
  3. PROVIDE EXISTING LANDSCAPE PLANS
  4. REVISIONS FROM LANDSCAPE PLANS
  5. REVISIONS FROM ELECTRICAL PLANS
  6. REVISIONS FROM PRELIMINARY PLANS

- WATER CONSTRUCTION NOTES**
1. INSTALL 2" PVC CONDUIT FOR IRRIGATION WATER LINE AND FINISH
  2. CONDUIT TO BE INSTALLED IN ACCORDANCE WITH ALL APPLICABLE CODES AND REGULATIONS
- NOTES**
1. EXISTING UTILITIES SHOWN ARE BASED ON AVAILABLE RECORDS OR PUBLIC UTILITY COMPANIES' DATA AND ARE NOT GUARANTEED TO BE ACCURATE. THE CONTRACTOR SHALL VERIFY THE LOCATION AND DEPTH OF ALL UTILITIES IN THE FIELD ON EXISTING AND PROPOSED TRENCHING WITH THE APPROPRIATE UTILITY COMPANIES PRIOR TO CONSTRUCTION. THE CONTRACTOR SHALL PROTECT ALL UTILITIES IN THE FIELD ON EXISTING AND PROPOSED TRENCHING WITH THE APPROPRIATE UTILITY COMPANIES PRIOR TO CONSTRUCTION.
  2. SEE ALL OTHER NOTES ON THIS SHEET FOR ADDITIONAL INFORMATION.
  3. ALL CONSTRUCTION SHALL BE IN ACCORDANCE WITH ALL APPLICABLE CODES AND REGULATIONS.
  4. THE CONTRACTOR SHALL BE RESPONSIBLE FOR OBTAINING ALL NECESSARY PERMITS AND APPROVALS FROM THE LOCAL AUTHORITIES.
  5. THE CONTRACTOR SHALL MAINTAIN ACCESS TO ALL ADJACENT PROPERTIES AND UTILITIES AT ALL TIMES.
  6. THE CONTRACTOR SHALL MAINTAIN ALL EXISTING UTILITIES AND STRUCTURES UNLESS OTHERWISE NOTED.
  7. THE CONTRACTOR SHALL MAINTAIN ALL EXISTING UTILITIES AND STRUCTURES UNLESS OTHERWISE NOTED.
  8. THE CONTRACTOR SHALL MAINTAIN ALL EXISTING UTILITIES AND STRUCTURES UNLESS OTHERWISE NOTED.
  9. THE CONTRACTOR SHALL MAINTAIN ALL EXISTING UTILITIES AND STRUCTURES UNLESS OTHERWISE NOTED.
  10. THE CONTRACTOR SHALL MAINTAIN ALL EXISTING UTILITIES AND STRUCTURES UNLESS OTHERWISE NOTED.

- CONSTRUCTION NOTES**
1. PROJECT SHALL BE COMPLETED BY 10/31/2024
  2. CONSTRUCTION SHALL BE IN ACCORDANCE WITH ALL APPLICABLE CODES AND REGULATIONS
  3. CONSTRUCTION SHALL BE IN ACCORDANCE WITH ALL APPLICABLE CODES AND REGULATIONS
  4. CONSTRUCTION SHALL BE IN ACCORDANCE WITH ALL APPLICABLE CODES AND REGULATIONS
  5. CONSTRUCTION SHALL BE IN ACCORDANCE WITH ALL APPLICABLE CODES AND REGULATIONS
  6. CONSTRUCTION SHALL BE IN ACCORDANCE WITH ALL APPLICABLE CODES AND REGULATIONS
  7. CONSTRUCTION SHALL BE IN ACCORDANCE WITH ALL APPLICABLE CODES AND REGULATIONS
  8. CONSTRUCTION SHALL BE IN ACCORDANCE WITH ALL APPLICABLE CODES AND REGULATIONS
  9. CONSTRUCTION SHALL BE IN ACCORDANCE WITH ALL APPLICABLE CODES AND REGULATIONS
  10. CONSTRUCTION SHALL BE IN ACCORDANCE WITH ALL APPLICABLE CODES AND REGULATIONS

	CLIENT: CLARENCE AND ANNE'S AREA 411 E. CHANAMAN AVE. PLACENTIA, CA 92679	<b>OUTDOOR LIBRARY</b>	PROJECT NAME: 411 E. CHANAMAN AVE. PLACENTIA, CA 92679	PROJECT NO.: 23X117.00	SHEET NO.: 15 OF 53
					
1 PETERS CANYON ROAD, SUITE 100 TEL: 949.341.4800 FAX: 949.341.4800					
<b>PROJECT IDENTIFICATION</b>					
NO.	DESCRIPTION	DATE			
1	PLANNING/SCHEMATIC	05/2024			
2	PRELIMINARY DESIGN	06/2024			
3	FINAL DESIGN/CONSTRUCTION	07/2024			
<b>APPROVED BY</b>					
DESIGNED BY	CHECKED BY	DATE			
HN	AS	05/21/2024			
<b>IMPROVEMENT PLANS</b>					
<b>C-200</b>					

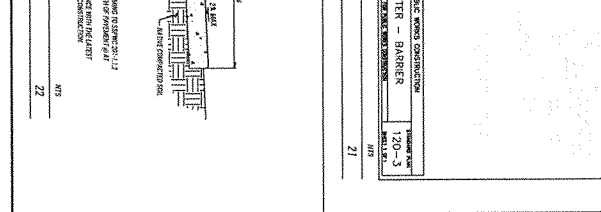
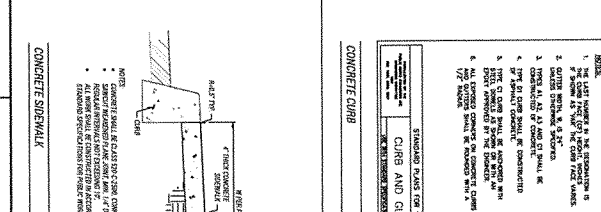
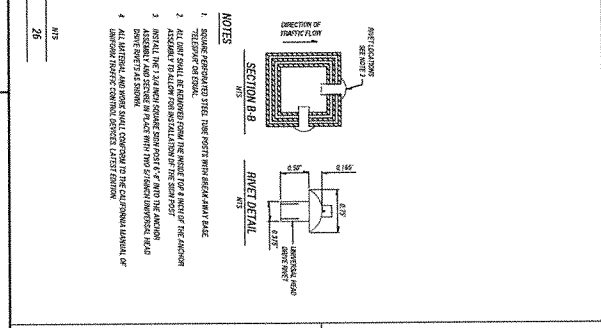
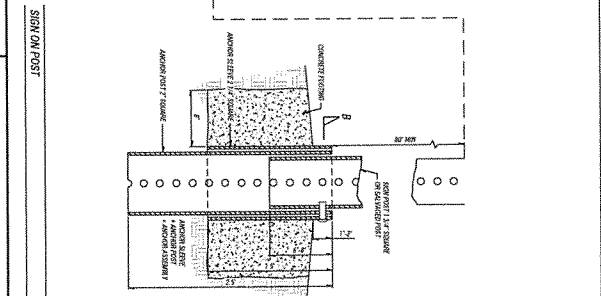
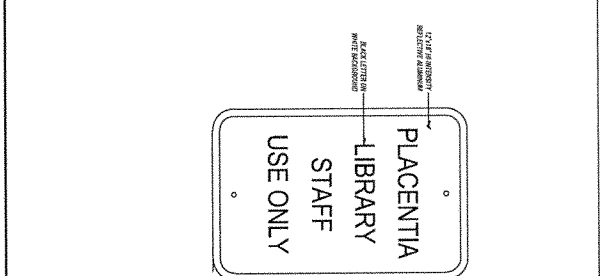
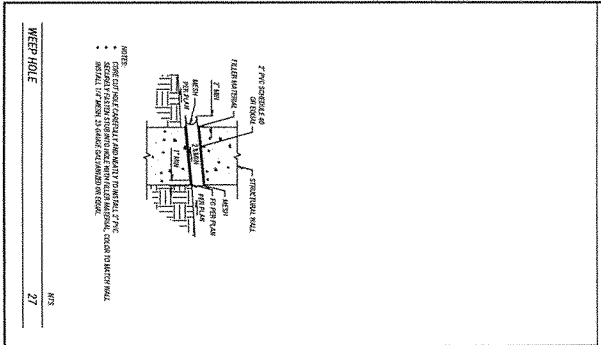

**KINGSLEY**  
LIBRARY RETURN SYSTEMS AND SOLUTIONS

### Outdoor Depositories

Product: 50 C-Series  
Catalog #: 00-9190

Specifications are subject to change without notice. Please see www.kingsley.com for the most current specifications. Made in the USA.

#### Outside Return Construction Features

An optional built-in 12 gauge aircraft grade aluminum for high strength and excellent door resistance.

**Weathering:** Easy roll design hood extension for year convenience.

**Weather Resistance:** High quality 20 gauge galvanized coating provides rust and corrosion resistance. Hood and return system is formed on steel work from inside the depository. Slated and rubber hood flaps extend from the hood. Slated hood flaps extend and keep water away from entering at top of door frame.

**Third Transoms:** Exclusive King'sley push-down chain lifting. Full-length stainless steel hinges on access door. No corner seams to pull apart.

**Fire Approvals:** Aircraft design another need files to meet fire 1 transmit blocks, Blue, Green, Orange, Yellow, Silver/White, or White. Includes fire-rated door seal.

**Available Finishes:** See website for available finishes options.

**Loading Methods:** - Deposition Opening (2) hand methods - Chain and Tower 3 (hand feeding) from bottom, and opening with) keypad loaded back with weather sealed back cover to prevent freezing and keep air out.

**Liquid Drainage System:** Designed to divert liquid from the depository opening away from the collection area.

**ADA Compliance:** ADA compliant when properly installed.

**Assembly Required:** Ships fully assembled.

Manufactured in the USA

**KINGSLEY**  
LIBRARY RETURN SYSTEMS AND SOLUTIONS

### Outside Return Measurements

Overall Dimensions: 30" W x 42 1/2" D x 53.54" H  
1524 mm W x 1082.5 mm D x 1369 mm H  
Footprint of cabinet is 30" square. Head is 42 1/2" x 53.54" H.

**Depository Opening:** 17 1/2" W x 4 1/2" H  
154 mm W x 113 mm H

**Product Weight:** 81 lbs, 129.54 kg

**Shipping Methods/Classes:** Freight Class 150

Transport Class Used with This System:  
 620-6000 - High Capacity Cart  
 620-6000 - High Capacity Rainout Cart  
 620-6000 - Standard Rainout Cart  
 620-6000 - Standard Rainout Cart  
 620-6000 - Standard Rainout Cart  
 620-6000 - Standard Rainout Cart  
 620-6000 - Standard Rainout Cart  
 620-6000 - Standard Rainout Cart  
 620-6000 - Standard Rainout Cart  
 620-6000 - Standard Rainout Cart

Accessories/Options for This System:  
 Handles: 12" BUCK DROP (999-8180) or VIDEO DROP (999-8185)  
 Handing Tray - Handle BUCK DROP (999-8180) or VIDEO DROP (999-8185)  
 Signage: 6" x 6" x 1/8" (999-8180) or 6" x 6" x 1/8" (999-8185)  
 Custom Wrapping/Designs - Contact us for a quote.  
 Custom Prints - Contact us for a quote.

PLEASE NOTE: Cart capacities vary. See our specifications for more information.

Manufactured in the USA

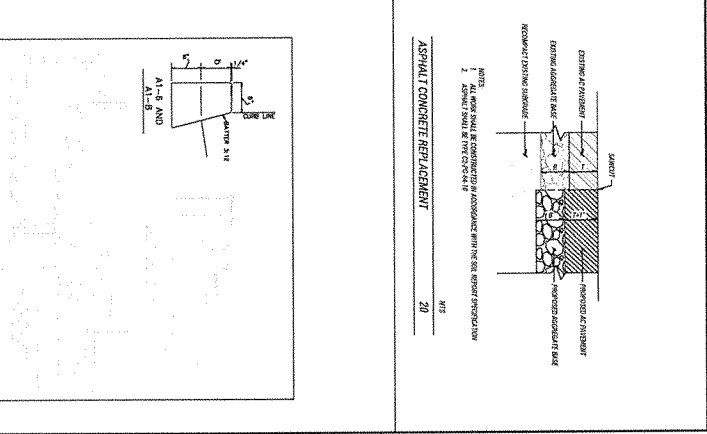

CENTRIFUGAL CASTING AND ANCHORED JOINTS  
411 E. CHAPMAN AVE.  
PLACENTIA, CA 92770  
TEL: 949.861.3933 FAX: 949.861.3950

### OUTDOOR LIBRARY

PROJECT NAME

---

**placentia**  
LIBRARY DISTRICT

---

411 E. CHAPMAN AVE.  
PLACENTIA, CA 92770  
TEL: 949.861.3933 FAX: 949.861.3950

**IDS GROUP**  
1 PETERS CANYON ROAD, SUITE 130  
IRVINE, CA 92614  
TEL: 949.861.3933 FAX: 949.861.3950

DATE: 8/21/2024  
PROJECT NO.: 23X117.00  
SHEET NO.: 18 OF 53

**PROJECT IDENTIFICATION**

PROJECT NO.: 23X117.00  
SHEET NO.: 18 OF 53

**DESIGNER**

DESIGNER: IDS GROUP  
DATE: 8/21/2024

**PROJECT IDENTIFICATION**

PROJECT NO.: 23X117.00  
SHEET NO.: 18 OF 53

**DESIGNER**

DESIGNER: IDS GROUP  
DATE: 8/21/2024

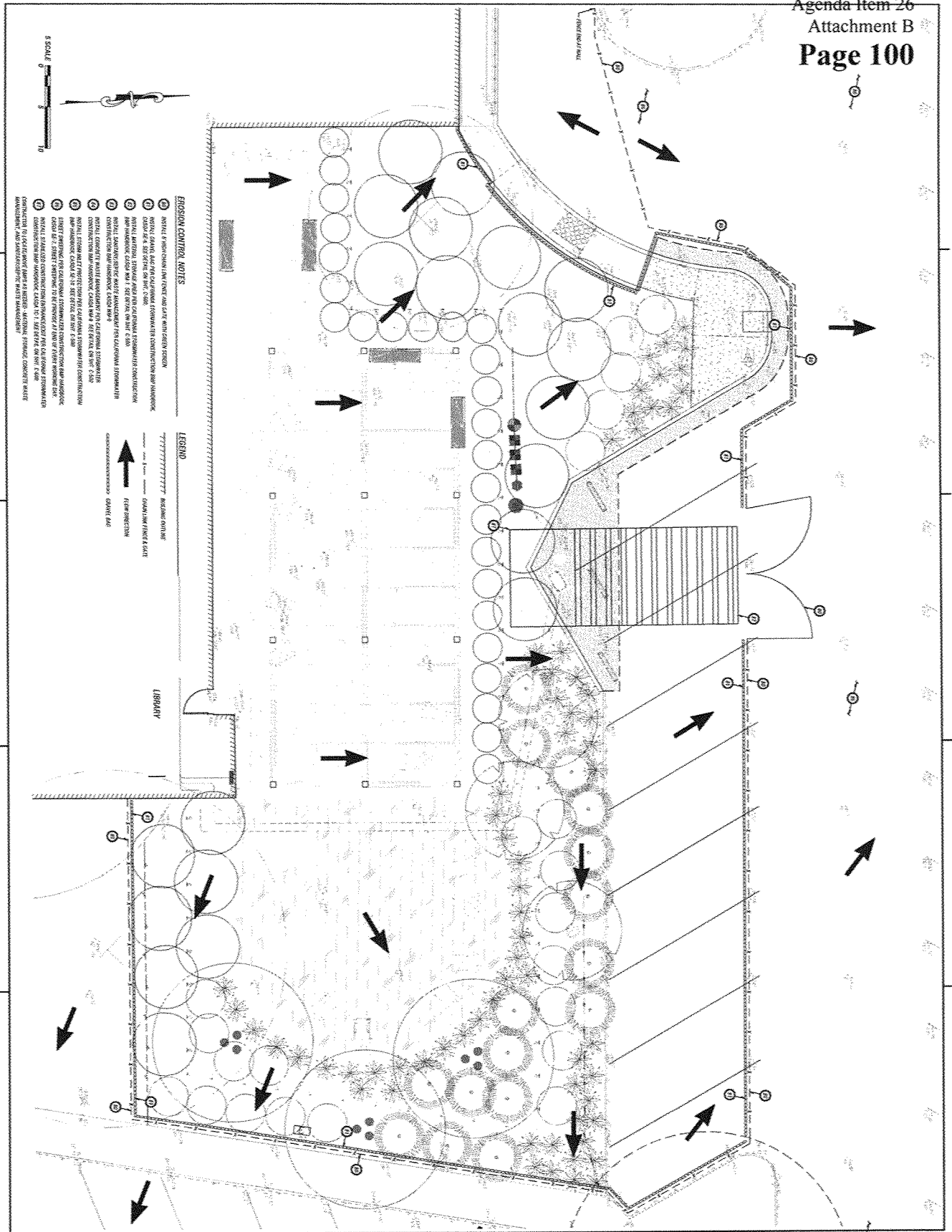

		CLIENT: LOS ANGELES AREA 411 E. SHARMAN AVE PLACENTIA, CA 92663	
<b>OUTDOOR LIBRARY</b>		PROJECT NO. 23X117.00	
		PROJECT IDENTIFICATION PROJECT NO. 23X117.00 SHEET NO. 17 OF 53	
1 PETERS CANNON ROAD, SUITE 150 IRVINE, CA 92618 TEL: 949.440.4800 FAX: 949.440.5000		PROJECT IDENTIFICATION PROJECT NO. 23X117.00 SHEET NO. 17 OF 53	
DATE 8/20/2024	REV. DESCRIPTION 1. INITIAL DESIGN	CHECKED BY AA	DESIGNED BY HNG
DATE 8/20/2024	REV. DESCRIPTION 2. REVISIONS	APPROVED BY AA	PROJECT NO. 23X117.00
DATE 8/20/2024	REV. DESCRIPTION 3. REVISIONS	PROJECT NO. 23X117.00	SHEET NO. 17 OF 53
DATE 8/20/2024	REV. DESCRIPTION 4. REVISIONS	PROJECT NO. 23X117.00	SHEET NO. 17 OF 53
DATE 8/20/2024	REV. DESCRIPTION 5. REVISIONS	PROJECT NO. 23X117.00	SHEET NO. 17 OF 53
DATE 8/20/2024	REV. DESCRIPTION 6. REVISIONS	PROJECT NO. 23X117.00	SHEET NO. 17 OF 53
DATE 8/20/2024	REV. DESCRIPTION 7. REVISIONS	PROJECT NO. 23X117.00	SHEET NO. 17 OF 53
DATE 8/20/2024	REV. DESCRIPTION 8. REVISIONS	PROJECT NO. 23X117.00	SHEET NO. 17 OF 53
DATE 8/20/2024	REV. DESCRIPTION 9. REVISIONS	PROJECT NO. 23X117.00	SHEET NO. 17 OF 53
DATE 8/20/2024	REV. DESCRIPTION 10. REVISIONS	PROJECT NO. 23X117.00	SHEET NO. 17 OF 53
DATE 8/20/2024	REV. DESCRIPTION 11. REVISIONS	PROJECT NO. 23X117.00	SHEET NO. 17 OF 53
DATE 8/20/2024	REV. DESCRIPTION 12. REVISIONS	PROJECT NO. 23X117.00	SHEET NO. 17 OF 53
DATE 8/20/2024	REV. DESCRIPTION 13. REVISIONS	PROJECT NO. 23X117.00	SHEET NO. 17 OF 53
DATE 8/20/2024	REV. DESCRIPTION 14. REVISIONS	PROJECT NO. 23X117.00	SHEET NO. 17 OF 53
DATE 8/20/2024	REV. DESCRIPTION 15. REVISIONS	PROJECT NO. 23X117.00	SHEET NO. 17 OF 53
DATE 8/20/2024	REV. DESCRIPTION 16. REVISIONS	PROJECT NO. 23X117.00	SHEET NO. 17 OF 53
DATE 8/20/2024	REV. DESCRIPTION 17. REVISIONS	PROJECT NO. 23X117.00	SHEET NO. 17 OF 53
DATE 8/20/2024	REV. DESCRIPTION 18. REVISIONS	PROJECT NO. 23X117.00	SHEET NO. 17 OF 53
DATE 8/20/2024	REV. DESCRIPTION 19. REVISIONS	PROJECT NO. 23X117.00	SHEET NO. 17 OF 53
DATE 8/20/2024	REV. DESCRIPTION 20. REVISIONS	PROJECT NO. 23X117.00	SHEET NO. 17 OF 53
DATE 8/20/2024	REV. DESCRIPTION 21. REVISIONS	PROJECT NO. 23X117.00	SHEET NO. 17 OF 53
DATE 8/20/2024	REV. DESCRIPTION 22. REVISIONS	PROJECT NO. 23X117.00	SHEET NO. 17 OF 53
DATE 8/20/2024	REV. DESCRIPTION 23. REVISIONS	PROJECT NO. 23X117.00	SHEET NO. 17 OF 53
DATE 8/20/2024	REV. DESCRIPTION 24. REVISIONS	PROJECT NO. 23X117.00	SHEET NO. 17 OF 53
DATE 8/20/2024	REV. DESCRIPTION 25. REVISIONS	PROJECT NO. 23X117.00	SHEET NO. 17 OF 53
DATE 8/20/2024	REV. DESCRIPTION 26. REVISIONS	PROJECT NO. 23X117.00	SHEET NO. 17 OF 53
DATE 8/20/2024	REV. DESCRIPTION 27. REVISIONS	PROJECT NO. 23X117.00	SHEET NO. 17 OF 53
DATE 8/20/2024	REV. DESCRIPTION 28. REVISIONS	PROJECT NO. 23X117.00	SHEET NO. 17 OF 53
DATE 8/20/2024	REV. DESCRIPTION 29. REVISIONS	PROJECT NO. 23X117.00	SHEET NO. 17 OF 53
DATE 8/20/2024	REV. DESCRIPTION 30. REVISIONS	PROJECT NO. 23X117.00	SHEET NO. 17 OF 53
DATE 8/20/2024	REV. DESCRIPTION 31. REVISIONS	PROJECT NO. 23X117.00	SHEET NO. 17 OF 53
DATE 8/20/2024	REV. DESCRIPTION 32. REVISIONS	PROJECT NO. 23X117.00	SHEET NO. 17 OF 53
DATE 8/20/2024	REV. DESCRIPTION 33. REVISIONS	PROJECT NO. 23X117.00	SHEET NO. 17 OF 53
DATE 8/20/2024	REV. DESCRIPTION 34. REVISIONS	PROJECT NO. 23X117.00	SHEET NO. 17 OF 53
DATE 8/20/2024	REV. DESCRIPTION 35. REVISIONS	PROJECT NO. 23X117.00	SHEET NO. 17 OF 53
DATE 8/20/2024	REV. DESCRIPTION 36. REVISIONS	PROJECT NO. 23X117.00	SHEET NO. 17 OF 53
DATE 8/20/2024	REV. DESCRIPTION 37. REVISIONS	PROJECT NO. 23X117.00	SHEET NO. 17 OF 53
DATE 8/20/2024	REV. DESCRIPTION 38. REVISIONS	PROJECT NO. 23X117.00	SHEET NO. 17 OF 53
DATE 8/20/2024	REV. DESCRIPTION 39. REVISIONS	PROJECT NO. 23X117.00	SHEET NO. 17 OF 53
DATE 8/20/2024	REV. DESCRIPTION 40. REVISIONS	PROJECT NO. 23X117.00	SHEET NO. 17 OF 53
DATE 8/20/2024	REV. DESCRIPTION 41. REVISIONS	PROJECT NO. 23X117.00	SHEET NO. 17 OF 53
DATE 8/20/2024	REV. DESCRIPTION 42. REVISIONS	PROJECT NO. 23X117.00	SHEET NO. 17 OF 53
DATE 8/20/2024	REV. DESCRIPTION 43. REVISIONS	PROJECT NO. 23X117.00	SHEET NO. 17 OF 53
DATE 8/20/2024	REV. DESCRIPTION 44. REVISIONS	PROJECT NO. 23X117.00	SHEET NO. 17 OF 53
DATE 8/20/2024	REV. DESCRIPTION 45. REVISIONS	PROJECT NO. 23X117.00	SHEET NO. 17 OF 53
DATE 8/20/2024	REV. DESCRIPTION 46. REVISIONS	PROJECT NO. 23X117.00	SHEET NO. 17 OF 53
DATE 8/20/2024	REV. DESCRIPTION 47. REVISIONS	PROJECT NO. 23X117.00	SHEET NO. 17 OF 53
DATE 8/20/2024	REV. DESCRIPTION 48. REVISIONS	PROJECT NO. 23X117.00	SHEET NO. 17 OF 53
DATE 8/20/2024	REV. DESCRIPTION 49. REVISIONS	PROJECT NO. 23X117.00	SHEET NO. 17 OF 53
DATE 8/20/2024	REV. DESCRIPTION 50. REVISIONS	PROJECT NO. 23X117.00	SHEET NO. 17 OF 53



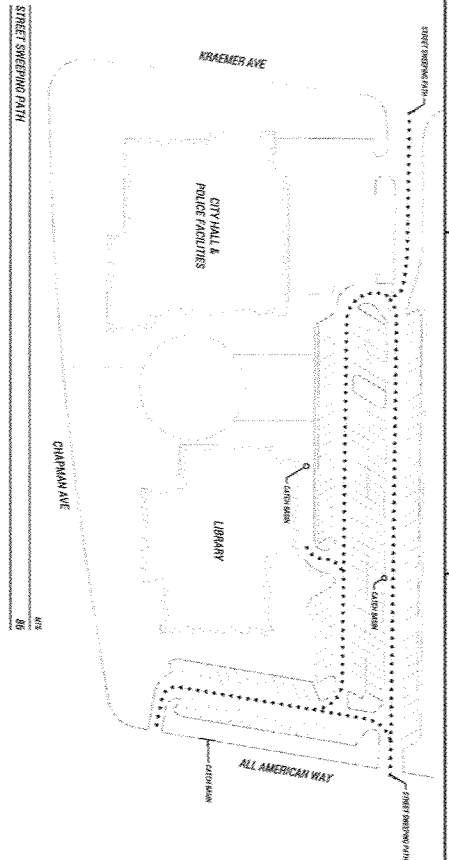

**EROSION AND SEDIMENT CONTROL:**

1. EROSION CONTROL SHALL BE INSTALLED PRIOR TO THE START OF ANY EARTHWORK OR CONSTRUCTION ACTIVITIES.
2. EROSION CONTROL SHALL BE MAINTAINED THROUGHOUT THE CONSTRUCTION PERIOD.
3. EROSION CONTROL SHALL BE REMOVED IMMEDIATELY UPON COMPLETION OF CONSTRUCTION.
4. EROSION CONTROL SHALL BE INSTALLED TO PREVENT SOIL EROSION AND SEDIMENTATION FROM THE SITE.
5. EROSION CONTROL SHALL BE INSTALLED TO PREVENT SOIL EROSION AND SEDIMENTATION FROM THE SITE.
6. EROSION CONTROL SHALL BE INSTALLED TO PREVENT SOIL EROSION AND SEDIMENTATION FROM THE SITE.
7. EROSION CONTROL SHALL BE INSTALLED TO PREVENT SOIL EROSION AND SEDIMENTATION FROM THE SITE.
8. EROSION CONTROL SHALL BE INSTALLED TO PREVENT SOIL EROSION AND SEDIMENTATION FROM THE SITE.
9. EROSION CONTROL SHALL BE INSTALLED TO PREVENT SOIL EROSION AND SEDIMENTATION FROM THE SITE.
10. EROSION CONTROL SHALL BE INSTALLED TO PREVENT SOIL EROSION AND SEDIMENTATION FROM THE SITE.

**BMP MANAGEMENT PRACTICE REFERENCE LIST:**

- CONSTRUCTION BEST MANAGEMENT PRACTICES (BMPs)**
- CC1: EROSION CONTROL
  - CC2: SEDIMENT CONTROL
  - CC3: SLOPE PROTECTION
  - CC4: STABILIZED CONSTRUCTION ENTRANCE
  - CC5: STABILIZED CONSTRUCTION ENTRANCE
  - CC6: STABILIZED CONSTRUCTION ENTRANCE
  - CC7: STABILIZED CONSTRUCTION ENTRANCE
  - CC8: STABILIZED CONSTRUCTION ENTRANCE
  - CC9: STABILIZED CONSTRUCTION ENTRANCE
  - CC10: STABILIZED CONSTRUCTION ENTRANCE
  - CC11: STABILIZED CONSTRUCTION ENTRANCE
  - CC12: STABILIZED CONSTRUCTION ENTRANCE
  - CC13: STABILIZED CONSTRUCTION ENTRANCE
  - CC14: STABILIZED CONSTRUCTION ENTRANCE
  - CC15: STABILIZED CONSTRUCTION ENTRANCE
  - CC16: STABILIZED CONSTRUCTION ENTRANCE
  - CC17: STABILIZED CONSTRUCTION ENTRANCE
  - CC18: STABILIZED CONSTRUCTION ENTRANCE
  - CC19: STABILIZED CONSTRUCTION ENTRANCE
  - CC20: STABILIZED CONSTRUCTION ENTRANCE
  - CC21: STABILIZED CONSTRUCTION ENTRANCE
  - CC22: STABILIZED CONSTRUCTION ENTRANCE
  - CC23: STABILIZED CONSTRUCTION ENTRANCE
  - CC24: STABILIZED CONSTRUCTION ENTRANCE
  - CC25: STABILIZED CONSTRUCTION ENTRANCE
  - CC26: STABILIZED CONSTRUCTION ENTRANCE
  - CC27: STABILIZED CONSTRUCTION ENTRANCE
  - CC28: STABILIZED CONSTRUCTION ENTRANCE
  - CC29: STABILIZED CONSTRUCTION ENTRANCE
  - CC30: STABILIZED CONSTRUCTION ENTRANCE
  - CC31: STABILIZED CONSTRUCTION ENTRANCE
  - CC32: STABILIZED CONSTRUCTION ENTRANCE
  - CC33: STABILIZED CONSTRUCTION ENTRANCE
  - CC34: STABILIZED CONSTRUCTION ENTRANCE
  - CC35: STABILIZED CONSTRUCTION ENTRANCE
  - CC36: STABILIZED CONSTRUCTION ENTRANCE
  - CC37: STABILIZED CONSTRUCTION ENTRANCE
  - CC38: STABILIZED CONSTRUCTION ENTRANCE
  - CC39: STABILIZED CONSTRUCTION ENTRANCE
  - CC40: STABILIZED CONSTRUCTION ENTRANCE
  - CC41: STABILIZED CONSTRUCTION ENTRANCE
  - CC42: STABILIZED CONSTRUCTION ENTRANCE
  - CC43: STABILIZED CONSTRUCTION ENTRANCE
  - CC44: STABILIZED CONSTRUCTION ENTRANCE
  - CC45: STABILIZED CONSTRUCTION ENTRANCE
  - CC46: STABILIZED CONSTRUCTION ENTRANCE
  - CC47: STABILIZED CONSTRUCTION ENTRANCE
  - CC48: STABILIZED CONSTRUCTION ENTRANCE
  - CC49: STABILIZED CONSTRUCTION ENTRANCE
  - CC50: STABILIZED CONSTRUCTION ENTRANCE
  - CC51: STABILIZED CONSTRUCTION ENTRANCE
  - CC52: STABILIZED CONSTRUCTION ENTRANCE
  - CC53: STABILIZED CONSTRUCTION ENTRANCE
  - CC54: STABILIZED CONSTRUCTION ENTRANCE
  - CC55: STABILIZED CONSTRUCTION ENTRANCE
  - CC56: STABILIZED CONSTRUCTION ENTRANCE
  - CC57: STABILIZED CONSTRUCTION ENTRANCE
  - CC58: STABILIZED CONSTRUCTION ENTRANCE
  - CC59: STABILIZED CONSTRUCTION ENTRANCE
  - CC60: STABILIZED CONSTRUCTION ENTRANCE
  - CC61: STABILIZED CONSTRUCTION ENTRANCE
  - CC62: STABILIZED CONSTRUCTION ENTRANCE
  - CC63: STABILIZED CONSTRUCTION ENTRANCE
  - CC64: STABILIZED CONSTRUCTION ENTRANCE
  - CC65: STABILIZED CONSTRUCTION ENTRANCE
  - CC66: STABILIZED CONSTRUCTION ENTRANCE
  - CC67: STABILIZED CONSTRUCTION ENTRANCE
  - CC68: STABILIZED CONSTRUCTION ENTRANCE
  - CC69: STABILIZED CONSTRUCTION ENTRANCE
  - CC70: STABILIZED CONSTRUCTION ENTRANCE
  - CC71: STABILIZED CONSTRUCTION ENTRANCE
  - CC72: STABILIZED CONSTRUCTION ENTRANCE
  - CC73: STABILIZED CONSTRUCTION ENTRANCE
  - CC74: STABILIZED CONSTRUCTION ENTRANCE
  - CC75: STABILIZED CONSTRUCTION ENTRANCE
  - CC76: STABILIZED CONSTRUCTION ENTRANCE
  - CC77: STABILIZED CONSTRUCTION ENTRANCE
  - CC78: STABILIZED CONSTRUCTION ENTRANCE
  - CC79: STABILIZED CONSTRUCTION ENTRANCE
  - CC80: STABILIZED CONSTRUCTION ENTRANCE
  - CC81: STABILIZED CONSTRUCTION ENTRANCE
  - CC82: STABILIZED CONSTRUCTION ENTRANCE
  - CC83: STABILIZED CONSTRUCTION ENTRANCE
  - CC84: STABILIZED CONSTRUCTION ENTRANCE
  - CC85: STABILIZED CONSTRUCTION ENTRANCE
  - CC86: STABILIZED CONSTRUCTION ENTRANCE
  - CC87: STABILIZED CONSTRUCTION ENTRANCE
  - CC88: STABILIZED CONSTRUCTION ENTRANCE
  - CC89: STABILIZED CONSTRUCTION ENTRANCE
  - CC90: STABILIZED CONSTRUCTION ENTRANCE
  - CC91: STABILIZED CONSTRUCTION ENTRANCE
  - CC92: STABILIZED CONSTRUCTION ENTRANCE
  - CC93: STABILIZED CONSTRUCTION ENTRANCE
  - CC94: STABILIZED CONSTRUCTION ENTRANCE
  - CC95: STABILIZED CONSTRUCTION ENTRANCE
  - CC96: STABILIZED CONSTRUCTION ENTRANCE
  - CC97: STABILIZED CONSTRUCTION ENTRANCE
  - CC98: STABILIZED CONSTRUCTION ENTRANCE
  - CC99: STABILIZED CONSTRUCTION ENTRANCE
  - CC100: STABILIZED CONSTRUCTION ENTRANCE

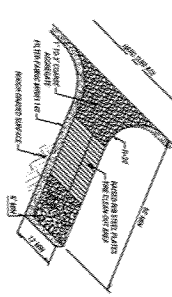

**STABILIZED CONSTRUCTION ENTRANCE**  
87

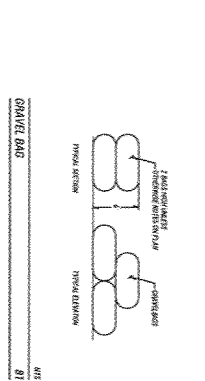

**GRAVEL BAG**  
81

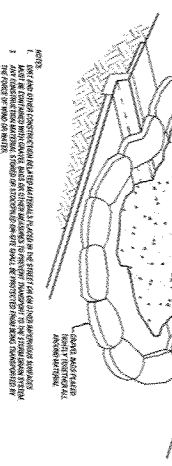

**MATERIAL STORAGE**  
82

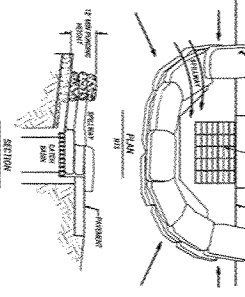

**INLET PROTECTION**  
85

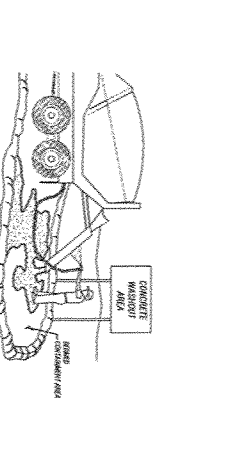

**CONCRETE WASTE MANAGEMENT**  
84

		411 E CHAMPLAIN AVE PLACENTIA, CA 92689	
<b>OUTDOOR LIBRARY</b>			
PROJECT NO: 23X117.00			
CONTRACTOR: IDS GROUP			
17185 CANON ROAD, SUITE 130 TEL: 949-361-6500, FAX: 949-343-6500			
PROJECT IDENTIFICATION			
NO.	DESCRIPTION	DATE	BY
1	Final Design Submittal	08/20/24	HN
2	Final Design Submittal	08/20/24	HN
PROJECT IDENTIFICATION			
THE INFORMATION CONTAINED HEREIN IS THE PROPERTY OF IDS GROUP AND IS NOT TO BE REPRODUCED OR TRANSMITTED IN ANY FORM OR BY ANY MEANS, ELECTRONIC OR MECHANICAL, INCLUDING PHOTOCOPYING, RECORDING, OR BY ANY INFORMATION STORAGE AND RETRIEVAL SYSTEM, WITHOUT THE WRITTEN PERMISSION OF IDS GROUP.			
IDS PROJECT NO. 23X117.00			
DRAWN BY: HN			
CHECKED BY: NA			
APPROVED BY:			
<b>EROSION CONTROL DETAILS</b>			
SHEET NO. 19 OF 23			



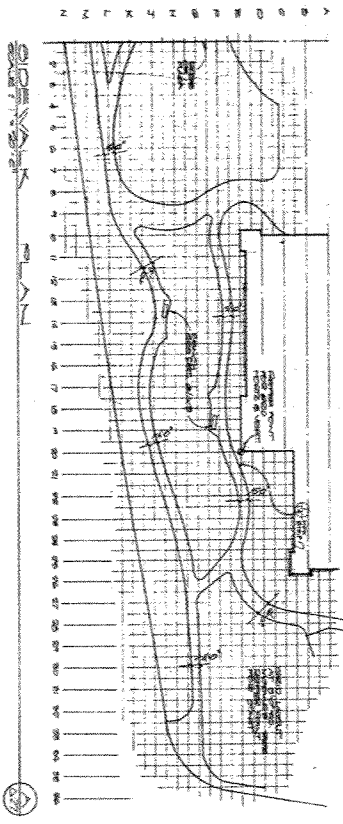
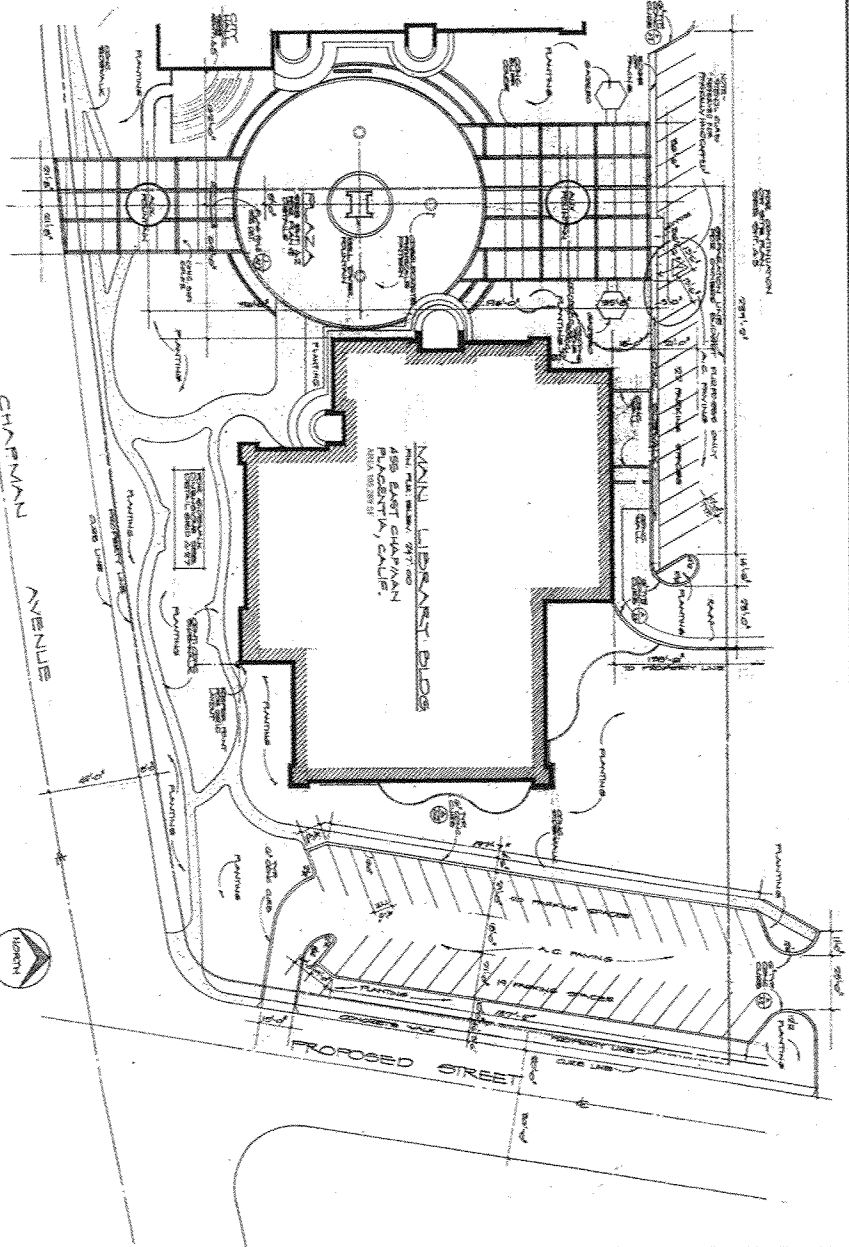
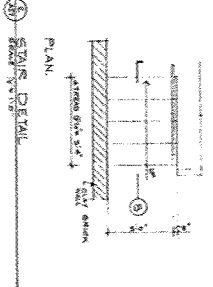
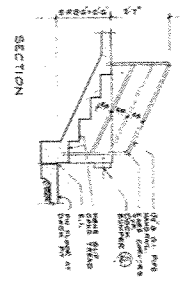
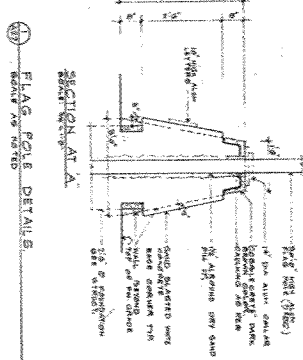
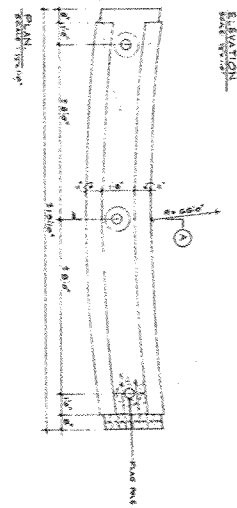
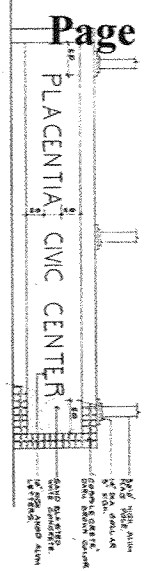

REFERENCE DRAWING ONLY

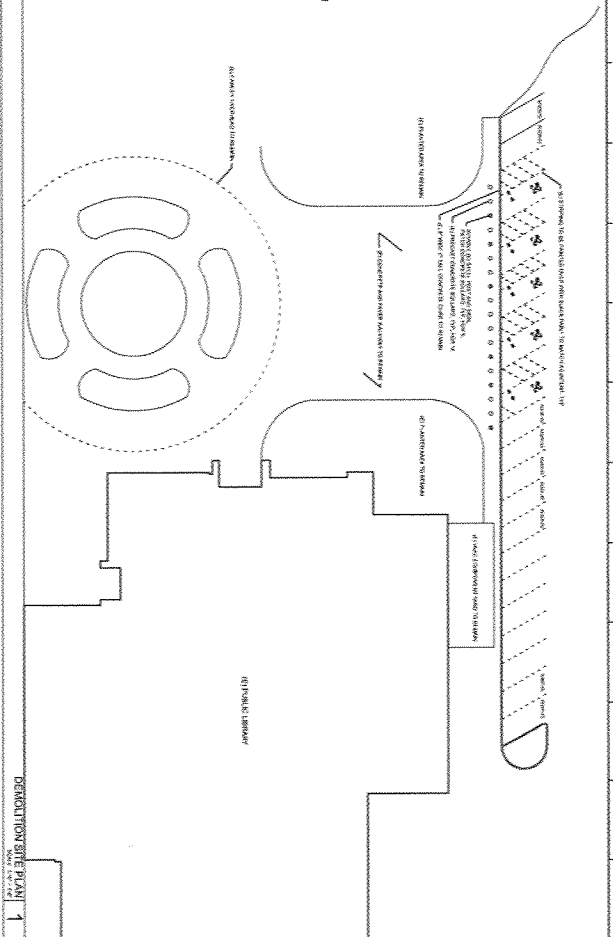
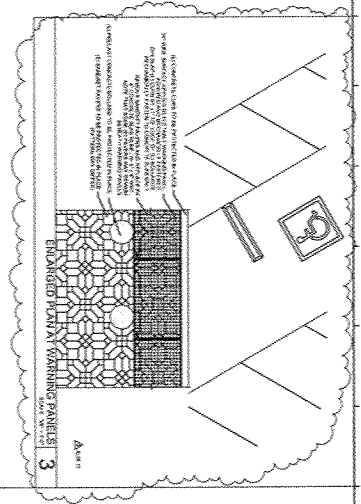

**Demolition Site Plan 1**  
 Scale: 1/8" = 1'-0"

**Placentia Library**  
 411 East Chapman Ave  
 Placentia, CA 92670  
 PLD-2018-203

**SEAED**  
 Structural Engineering and Architectural Design  
 411 East Chapman Ave, Suite 200  
 Placentia, CA 92670  
 Phone: (949) 781-1111  
 Fax: (949) 781-1112  
 Email: info@seaed.com  
 Website: www.seaed.com

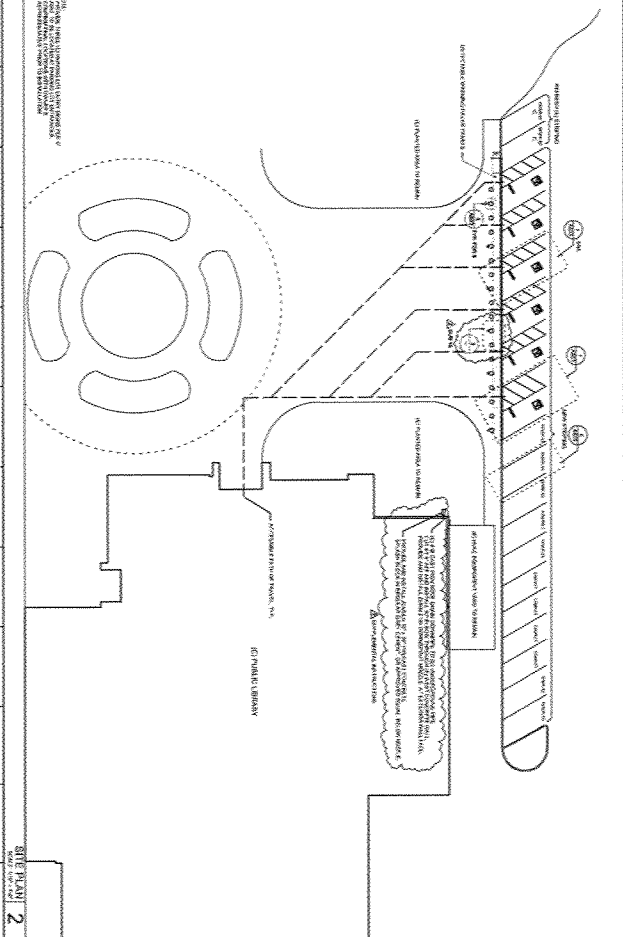





**Demolition Site Plan 2**  
 Scale: 1/8" = 1'-0"

**Placentia Library**  
 411 East Chapman Ave  
 Placentia, CA 92670  
 PLD-2018-203

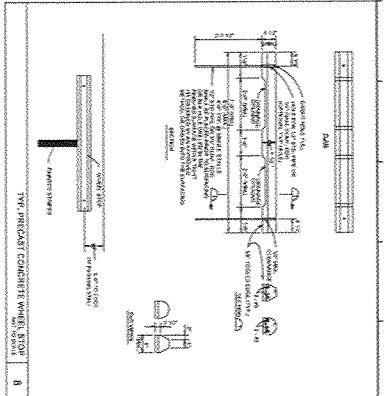
**SEAED**  
 Structural Engineering and Architectural Design  
 411 East Chapman Ave, Suite 200  
 Placentia, CA 92670  
 Phone: (949) 781-1111  
 Fax: (949) 781-1112  
 Email: info@seaed.com  
 Website: www.seaed.com

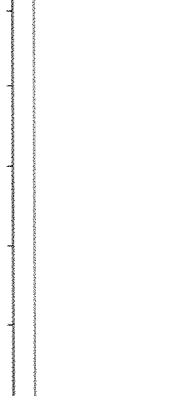
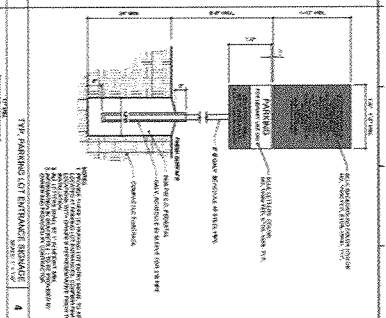
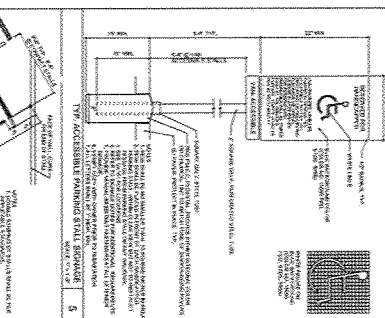
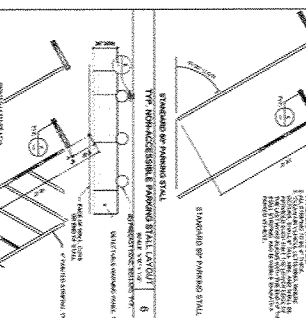
REFERENCE DRAWING ONLY

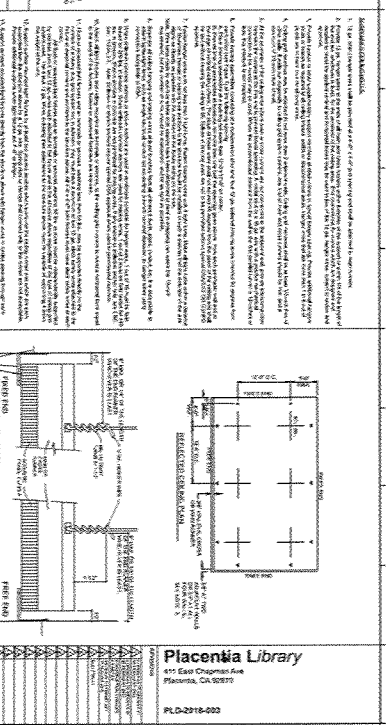
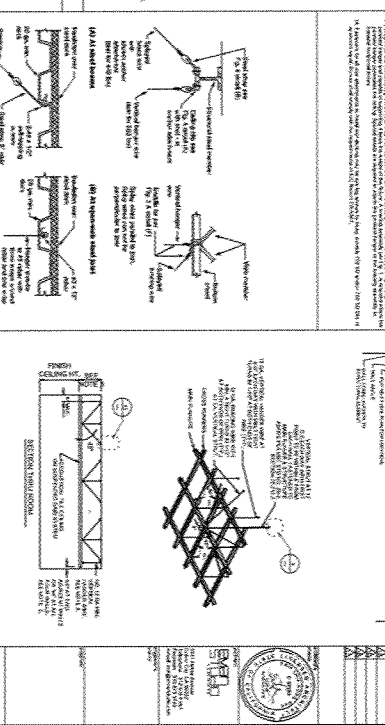
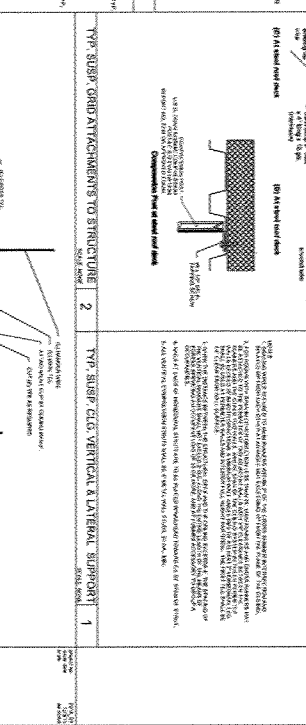
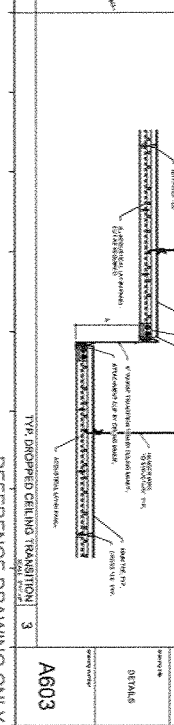
 <p>4. TYP. PRECAST CONCRETE WALL SECTION</p> <p>5. TYP. PRECAST CONCRETE WALL SECTION</p> <p>6. TYP. PRECAST CONCRETE WALL SECTION</p>	 <p>4. TYP. FORMWORK FOR ENTRANCE BEAM</p> <p>5. TYP. FORMWORK FOR ENTRANCE BEAM</p> <p>6. TYP. FORMWORK FOR ENTRANCE BEAM</p>	 <p>7. TYP. ACCESSIBLE PARKING STALL LAYOUT</p> <p>8. TYP. ACCESSIBLE PARKING STALL LAYOUT</p> <p>9. TYP. ACCESSIBLE PARKING STALL LAYOUT</p>	 <p>10. STANDARD FOR PARKING STALL</p> <p>11. STANDARD FOR PARKING STALL</p> <p>12. STANDARD FOR PARKING STALL</p>
 <p>2. TYP. SUBGRID ATTACHMENTS TO STRUCTURE</p> <p>3. TYP. SUBGRID ATTACHMENTS TO STRUCTURE</p>	 <p>4. TYP. SUBGRID ATTACHMENTS TO STRUCTURE</p> <p>5. TYP. SUBGRID ATTACHMENTS TO STRUCTURE</p>	 <p>6. TYP. SUBGRID ATTACHMENTS TO STRUCTURE</p> <p>7. TYP. SUBGRID ATTACHMENTS TO STRUCTURE</p>	 <p>8. TYP. SUBGRID ATTACHMENTS TO STRUCTURE</p> <p>9. TYP. SUBGRID ATTACHMENTS TO STRUCTURE</p>
 <p>10. TYP. SUBGRID ATTACHMENTS TO STRUCTURE</p> <p>11. TYP. SUBGRID ATTACHMENTS TO STRUCTURE</p>	 <p>12. TYP. SUBGRID ATTACHMENTS TO STRUCTURE</p> <p>13. TYP. SUBGRID ATTACHMENTS TO STRUCTURE</p>	 <p>14. TYP. SUBGRID ATTACHMENTS TO STRUCTURE</p> <p>15. TYP. SUBGRID ATTACHMENTS TO STRUCTURE</p>	 <p>16. TYP. SUBGRID ATTACHMENTS TO STRUCTURE</p> <p>17. TYP. SUBGRID ATTACHMENTS TO STRUCTURE</p>

REFERENCE DRAWING ONLY

A603

DETAILS

Placencia Library  
475 East Chapman Ave  
Placencia, CA 95072  
PLD-2016-002



IDS GROUP - FILE LOCATION: PLOT DATE: USER:

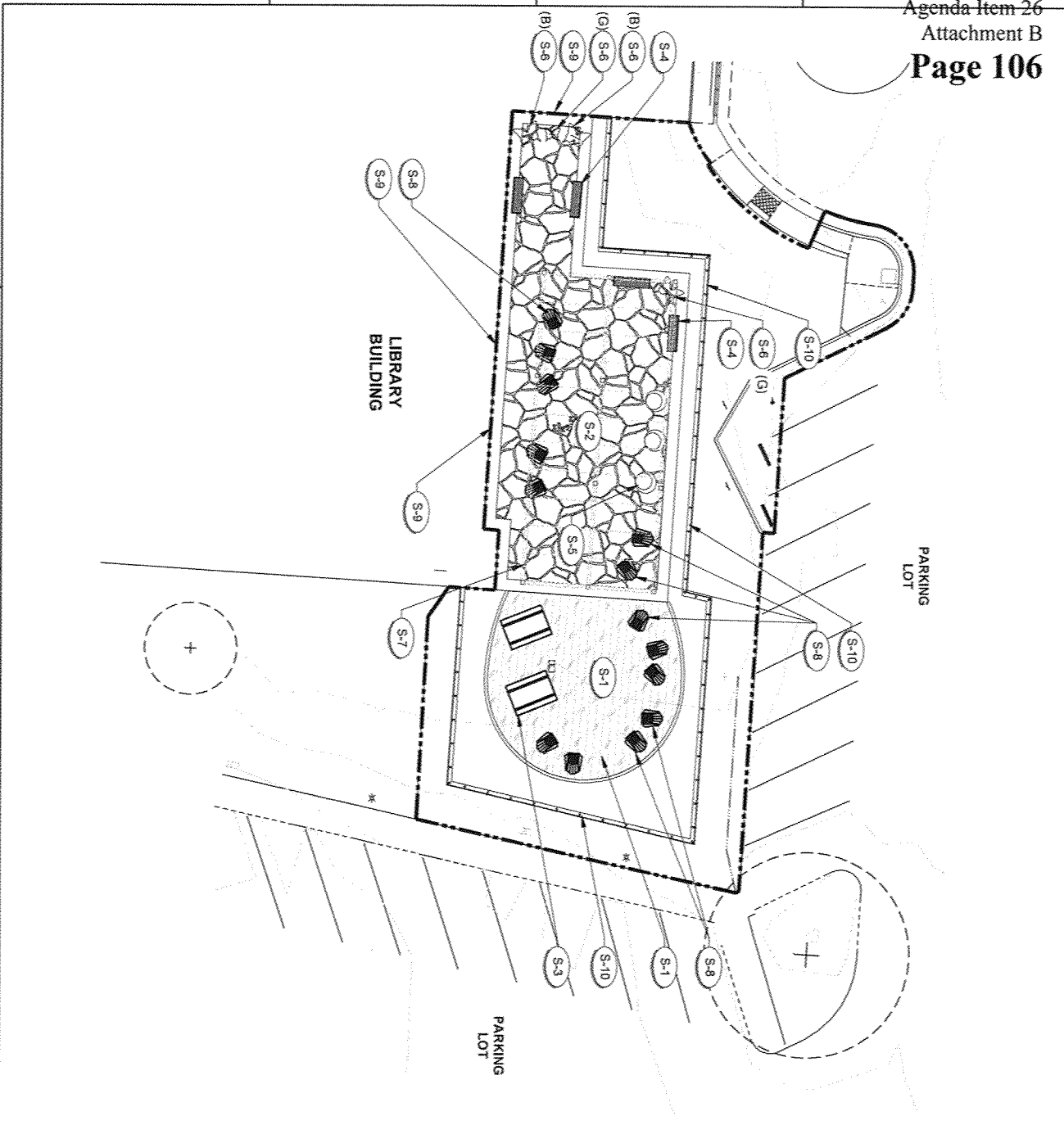

NO.	DESCRIPTION	ESTIMATED QUANTITY
S-1	ROUNDER REINFORCING BARS	2
S-2	FLASSTON FLOOR WITH CONCRETE GRESS	0
S-3	REBAR/STAINLESS STEEL MESH	0
S-4	ARTISAN FLOORING	0
S-5	WOOD FLOORING	0
S-6	WOOD FLOORING	0
S-7	WOOD FLOORING	0
S-8	WOOD FLOORING	0
S-9	WOOD FLOORING	0
S-10	WOOD FLOORING	0

**FINISH SCHEDULE**

S-1 ROUNDER REINFORCING BARS

S-2 FLASSTON FLOOR WITH CONCRETE GRESS

S-3 REBAR/STAINLESS STEEL MESH

S-4 ARTISAN FLOORING

S-5 WOOD FLOORING

S-6 WOOD FLOORING

S-7 WOOD FLOORING

S-8 WOOD FLOORING

S-9 WOOD FLOORING

S-10 WOOD FLOORING

1-10 DECOMPOSED GRANITE FINISH FLOORING

1-11 GRANITE FINISH FLOORING

1-12 GRANITE FINISH FLOORING

1-13 GRANITE FINISH FLOORING

1-14 GRANITE FINISH FLOORING

1-15 GRANITE FINISH FLOORING

1-16 GRANITE FINISH FLOORING

1-17 GRANITE FINISH FLOORING

1-18 GRANITE FINISH FLOORING

1-19 GRANITE FINISH FLOORING

1-20 GRANITE FINISH FLOORING

1-21 GRANITE FINISH FLOORING

1-22 GRANITE FINISH FLOORING

1-23 GRANITE FINISH FLOORING

1-24 GRANITE FINISH FLOORING

1-25 GRANITE FINISH FLOORING

1-26 GRANITE FINISH FLOORING

1-27 GRANITE FINISH FLOORING

1-28 GRANITE FINISH FLOORING

1-29 GRANITE FINISH FLOORING

1-30 GRANITE FINISH FLOORING

1-31 GRANITE FINISH FLOORING

1-32 GRANITE FINISH FLOORING

1-33 GRANITE FINISH FLOORING

1-34 GRANITE FINISH FLOORING

1-35 GRANITE FINISH FLOORING

1-36 GRANITE FINISH FLOORING

1-37 GRANITE FINISH FLOORING

1-38 GRANITE FINISH FLOORING

1-39 GRANITE FINISH FLOORING

1-40 GRANITE FINISH FLOORING

1-41 GRANITE FINISH FLOORING

1-42 GRANITE FINISH FLOORING

1-43 GRANITE FINISH FLOORING

1-44 GRANITE FINISH FLOORING

1-45 GRANITE FINISH FLOORING

1-46 GRANITE FINISH FLOORING

1-47 GRANITE FINISH FLOORING

1-48 GRANITE FINISH FLOORING

1-49 GRANITE FINISH FLOORING

1-50 GRANITE FINISH FLOORING

CL-100

SHEET NO. 19 OF 33

**IDS GROUP**

1 PETERS CANYON ROAD, SUITE 100  
IRVINE, CA 92618  
TEL: 949-381-8500 FAX: 949-381-2080

411 S. GARDEN AVE  
PLACENTIA, CALIFORNIA

**placentia**

LIBRARY DISTRICT

**OUTDOOR LIBRARY PATIO**

**PROJECT IDENTIFICATION**

PROJECT NO. 235117-001

DRAWN BY: [Name]

CHECKED BY: [Name]

APPROVED BY: [Name]

ITEM NO.	DESCRIPTION	QTY	UNIT	MODEL	FINISH	INSTALLATION	COMMENTS
1.1	WOOD CHAIRS	17	EA	WOOD CHAIRS	WOOD	SEE ARCHITECTURAL PLANS	
1.2	WOOD BENCH	1	EA	WOOD BENCH	WOOD	SEE ARCHITECTURAL PLANS	
1.3	WOOD TABLE	1	EA	WOOD TABLE	WOOD	SEE ARCHITECTURAL PLANS	
1.4	WOOD CHAIRS	17	EA	WOOD CHAIRS	WOOD	SEE ARCHITECTURAL PLANS	
1.5	WOOD BENCH	1	EA	WOOD BENCH	WOOD	SEE ARCHITECTURAL PLANS	
1.6	WOOD TABLE	1	EA	WOOD TABLE	WOOD	SEE ARCHITECTURAL PLANS	
1.7	WOOD CHAIRS	17	EA	WOOD CHAIRS	WOOD	SEE ARCHITECTURAL PLANS	
1.8	WOOD BENCH	1	EA	WOOD BENCH	WOOD	SEE ARCHITECTURAL PLANS	
1.9	WOOD TABLE	1	EA	WOOD TABLE	WOOD	SEE ARCHITECTURAL PLANS	
1.10	WOOD CHAIRS	17	EA	WOOD CHAIRS	WOOD	SEE ARCHITECTURAL PLANS	
1.11	WOOD BENCH	1	EA	WOOD BENCH	WOOD	SEE ARCHITECTURAL PLANS	
1.12	WOOD TABLE	1	EA	WOOD TABLE	WOOD	SEE ARCHITECTURAL PLANS	
1.13	WOOD CHAIRS	17	EA	WOOD CHAIRS	WOOD	SEE ARCHITECTURAL PLANS	
1.14	WOOD BENCH	1	EA	WOOD BENCH	WOOD	SEE ARCHITECTURAL PLANS	
1.15	WOOD TABLE	1	EA	WOOD TABLE	WOOD	SEE ARCHITECTURAL PLANS	
1.16	WOOD CHAIRS	17	EA	WOOD CHAIRS	WOOD	SEE ARCHITECTURAL PLANS	
1.17	WOOD BENCH	1	EA	WOOD BENCH	WOOD	SEE ARCHITECTURAL PLANS	
1.18	WOOD TABLE	1	EA	WOOD TABLE	WOOD	SEE ARCHITECTURAL PLANS	
1.19	WOOD CHAIRS	17	EA	WOOD CHAIRS	WOOD	SEE ARCHITECTURAL PLANS	
1.20	WOOD BENCH	1	EA	WOOD BENCH	WOOD	SEE ARCHITECTURAL PLANS	
1.21	WOOD TABLE	1	EA	WOOD TABLE	WOOD	SEE ARCHITECTURAL PLANS	
1.22	WOOD CHAIRS	17	EA	WOOD CHAIRS	WOOD	SEE ARCHITECTURAL PLANS	
1.23	WOOD BENCH	1	EA	WOOD BENCH	WOOD	SEE ARCHITECTURAL PLANS	
1.24	WOOD TABLE	1	EA	WOOD TABLE	WOOD	SEE ARCHITECTURAL PLANS	
1.25	WOOD CHAIRS	17	EA	WOOD CHAIRS	WOOD	SEE ARCHITECTURAL PLANS	
1.26	WOOD BENCH	1	EA	WOOD BENCH	WOOD	SEE ARCHITECTURAL PLANS	
1.27	WOOD TABLE	1	EA	WOOD TABLE	WOOD	SEE ARCHITECTURAL PLANS	
1.28	WOOD CHAIRS	17	EA	WOOD CHAIRS	WOOD	SEE ARCHITECTURAL PLANS	
1.29	WOOD BENCH	1	EA	WOOD BENCH	WOOD	SEE ARCHITECTURAL PLANS	
1.30	WOOD TABLE	1	EA	WOOD TABLE	WOOD	SEE ARCHITECTURAL PLANS	
1.31	WOOD CHAIRS	17	EA	WOOD CHAIRS	WOOD	SEE ARCHITECTURAL PLANS	
1.32	WOOD BENCH	1	EA	WOOD BENCH	WOOD	SEE ARCHITECTURAL PLANS	
1.33	WOOD TABLE	1	EA	WOOD TABLE	WOOD	SEE ARCHITECTURAL PLANS	
1.34	WOOD CHAIRS	17	EA	WOOD CHAIRS	WOOD	SEE ARCHITECTURAL PLANS	
1.35	WOOD BENCH	1	EA	WOOD BENCH	WOOD	SEE ARCHITECTURAL PLANS	
1.36	WOOD TABLE	1	EA	WOOD TABLE	WOOD	SEE ARCHITECTURAL PLANS	
1.37	WOOD CHAIRS	17	EA	WOOD CHAIRS	WOOD	SEE ARCHITECTURAL PLANS	
1.38	WOOD BENCH	1	EA	WOOD BENCH	WOOD	SEE ARCHITECTURAL PLANS	
1.39	WOOD TABLE	1	EA	WOOD TABLE	WOOD	SEE ARCHITECTURAL PLANS	
1.40	WOOD CHAIRS	17	EA	WOOD CHAIRS	WOOD	SEE ARCHITECTURAL PLANS	
1.41	WOOD BENCH	1	EA	WOOD BENCH	WOOD	SEE ARCHITECTURAL PLANS	
1.42	WOOD TABLE	1	EA	WOOD TABLE	WOOD	SEE ARCHITECTURAL PLANS	
1.43	WOOD CHAIRS	17	EA	WOOD CHAIRS	WOOD	SEE ARCHITECTURAL PLANS	
1.44	WOOD BENCH	1	EA	WOOD BENCH	WOOD	SEE ARCHITECTURAL PLANS	
1.45	WOOD TABLE	1	EA	WOOD TABLE	WOOD	SEE ARCHITECTURAL PLANS	
1.46	WOOD CHAIRS	17	EA	WOOD CHAIRS	WOOD	SEE ARCHITECTURAL PLANS	
1.47	WOOD BENCH	1	EA	WOOD BENCH	WOOD	SEE ARCHITECTURAL PLANS	
1.48	WOOD TABLE	1	EA	WOOD TABLE	WOOD	SEE ARCHITECTURAL PLANS	
1.49	WOOD CHAIRS	17	EA	WOOD CHAIRS	WOOD	SEE ARCHITECTURAL PLANS	
1.50	WOOD BENCH	1	EA	WOOD BENCH	WOOD	SEE ARCHITECTURAL PLANS	
1.51	WOOD TABLE	1	EA	WOOD TABLE	WOOD	SEE ARCHITECTURAL PLANS	
1.52	WOOD CHAIRS	17	EA	WOOD CHAIRS	WOOD	SEE ARCHITECTURAL PLANS	
1.53	WOOD BENCH	1	EA	WOOD BENCH	WOOD	SEE ARCHITECTURAL PLANS	
1.54	WOOD TABLE	1	EA	WOOD TABLE	WOOD	SEE ARCHITECTURAL PLANS	
1.55	WOOD CHAIRS	17	EA	WOOD CHAIRS	WOOD	SEE ARCHITECTURAL PLANS	
1.56	WOOD BENCH	1	EA	WOOD BENCH	WOOD	SEE ARCHITECTURAL PLANS	
1.57	WOOD TABLE	1	EA	WOOD TABLE	WOOD	SEE ARCHITECTURAL PLANS	
1.58	WOOD CHAIRS	17	EA	WOOD CHAIRS	WOOD	SEE ARCHITECTURAL PLANS	
1.59	WOOD BENCH	1	EA	WOOD BENCH	WOOD	SEE ARCHITECTURAL PLANS	
1.60	WOOD TABLE	1	EA	WOOD TABLE	WOOD	SEE ARCHITECTURAL PLANS	
1.61	WOOD CHAIRS	17	EA	WOOD CHAIRS	WOOD	SEE ARCHITECTURAL PLANS	
1.62	WOOD BENCH	1	EA	WOOD BENCH	WOOD	SEE ARCHITECTURAL PLANS	
1.63	WOOD TABLE	1	EA	WOOD TABLE	WOOD	SEE ARCHITECTURAL PLANS	
1.64	WOOD CHAIRS	17	EA	WOOD CHAIRS	WOOD	SEE ARCHITECTURAL PLANS	
1.65	WOOD BENCH	1	EA	WOOD BENCH	WOOD	SEE ARCHITECTURAL PLANS	
1.66	WOOD TABLE	1	EA	WOOD TABLE	WOOD	SEE ARCHITECTURAL PLANS	
1.67	WOOD CHAIRS	17	EA	WOOD CHAIRS	WOOD	SEE ARCHITECTURAL PLANS	
1.68	WOOD BENCH	1	EA	WOOD BENCH	WOOD	SEE ARCHITECTURAL PLANS	
1.69	WOOD TABLE	1	EA	WOOD TABLE	WOOD	SEE ARCHITECTURAL PLANS	
1.70	WOOD CHAIRS	17	EA	WOOD CHAIRS	WOOD	SEE ARCHITECTURAL PLANS	
1.71	WOOD BENCH	1	EA	WOOD BENCH	WOOD	SEE ARCHITECTURAL PLANS	
1.72	WOOD TABLE	1	EA	WOOD TABLE	WOOD	SEE ARCHITECTURAL PLANS	
1.73	WOOD CHAIRS	17	EA	WOOD CHAIRS	WOOD	SEE ARCHITECTURAL PLANS	
1.74	WOOD BENCH	1	EA	WOOD BENCH	WOOD	SEE ARCHITECTURAL PLANS	
1.75	WOOD TABLE	1	EA	WOOD TABLE	WOOD	SEE ARCHITECTURAL PLANS	
1.76	WOOD CHAIRS	17	EA	WOOD CHAIRS	WOOD	SEE ARCHITECTURAL PLANS	
1.77	WOOD BENCH	1	EA	WOOD BENCH	WOOD	SEE ARCHITECTURAL PLANS	
1.78	WOOD TABLE	1	EA	WOOD TABLE	WOOD	SEE ARCHITECTURAL PLANS	
1.79	WOOD CHAIRS	17	EA	WOOD CHAIRS	WOOD	SEE ARCHITECTURAL PLANS	
1.80	WOOD BENCH	1	EA	WOOD BENCH	WOOD	SEE ARCHITECTURAL PLANS	
1.81	WOOD TABLE	1	EA	WOOD TABLE	WOOD	SEE ARCHITECTURAL PLANS	
1.82	WOOD CHAIRS	17	EA	WOOD CHAIRS	WOOD	SEE ARCHITECTURAL PLANS	
1.83	WOOD BENCH	1	EA	WOOD BENCH	WOOD	SEE ARCHITECTURAL PLANS	
1.84	WOOD TABLE	1	EA	WOOD TABLE	WOOD	SEE ARCHITECTURAL PLANS	
1.85	WOOD CHAIRS	17	EA	WOOD CHAIRS	WOOD	SEE ARCHITECTURAL PLANS	
1.86	WOOD BENCH	1	EA	WOOD BENCH	WOOD	SEE ARCHITECTURAL PLANS	
1.87	WOOD TABLE	1	EA	WOOD TABLE	WOOD	SEE ARCHITECTURAL PLANS	
1.88	WOOD CHAIRS	17	EA	WOOD CHAIRS	WOOD	SEE ARCHITECTURAL PLANS	
1.89	WOOD BENCH	1	EA	WOOD BENCH	WOOD	SEE ARCHITECTURAL PLANS	
1.90	WOOD TABLE	1	EA	WOOD TABLE	WOOD	SEE ARCHITECTURAL PLANS	
1.91	WOOD CHAIRS	17	EA	WOOD CHAIRS	WOOD	SEE ARCHITECTURAL PLANS	
1.92	WOOD BENCH	1	EA	WOOD BENCH	WOOD	SEE ARCHITECTURAL PLANS	
1.93	WOOD TABLE	1	EA	WOOD TABLE	WOOD	SEE ARCHITECTURAL PLANS	
1.94	WOOD CHAIRS	17	EA	WOOD CHAIRS	WOOD	SEE ARCHITECTURAL PLANS	
1.95	WOOD BENCH	1	EA	WOOD BENCH	WOOD	SEE ARCHITECTURAL PLANS	
1.96	WOOD TABLE	1	EA	WOOD TABLE	WOOD	SEE ARCHITECTURAL PLANS	
1.97	WOOD CHAIRS	17	EA	WOOD CHAIRS	WOOD	SEE ARCHITECTURAL PLANS	
1.98	WOOD BENCH	1	EA	WOOD BENCH	WOOD	SEE ARCHITECTURAL PLANS	
1.99	WOOD TABLE	1	EA	WOOD TABLE	WOOD	SEE ARCHITECTURAL PLANS	
1.100	WOOD CHAIRS	17	EA	WOOD CHAIRS	WOOD	SEE ARCHITECTURAL PLANS	

PRODUCT IMAGES

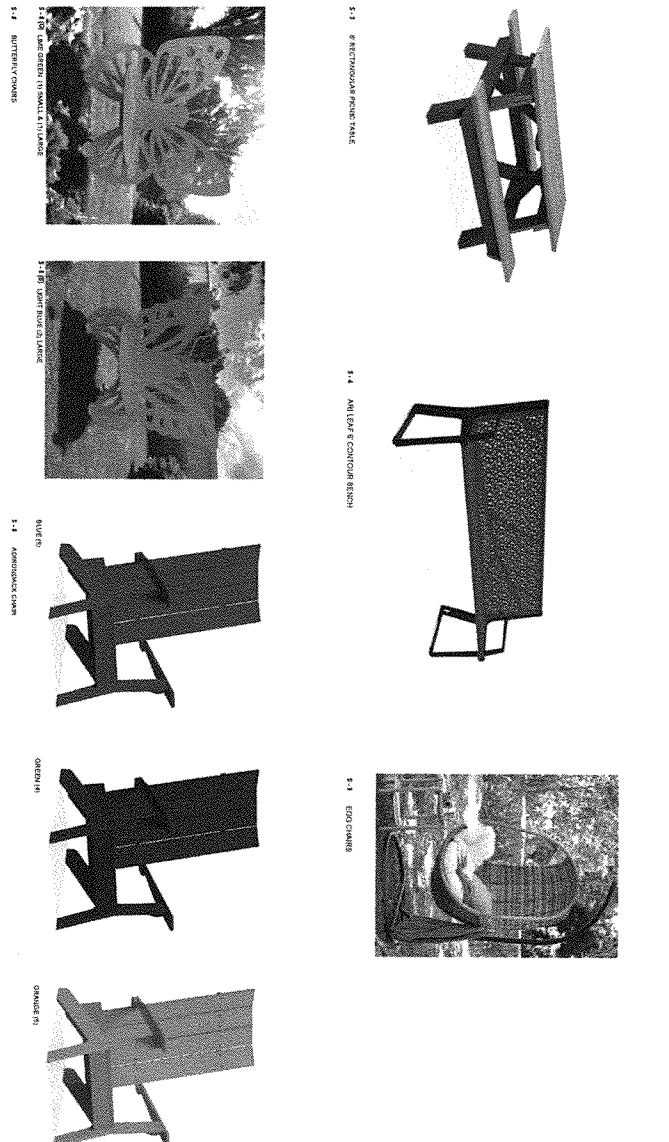

1.1 WOOD CHAIR  
1.2 WOOD BENCH  
1.3 WOOD TABLE  
1.4 WOOD CHAIR  
1.5 WOOD BENCH  
1.6 WOOD TABLE  
1.7 WOOD CHAIR  
1.8 WOOD BENCH  
1.9 WOOD TABLE  
1.10 WOOD CHAIR  
1.11 WOOD BENCH  
1.12 WOOD TABLE  
1.13 WOOD CHAIR  
1.14 WOOD BENCH  
1.15 WOOD TABLE

CLIENT  
placentia  
LIBRARY DISTRICT  
411 E. CHAPMAN AVE. PLACENTIA, CA 92670  
CLIENT LOGO AND ADDRESS HERE

PROJECT NAME  
OUTDOOR LIBRARY PATIO  
411 E. CHAPMAN AVE.  
PLACENTIA, CA 92670

IDS GROUP  
1 PETERS CANYON ROAD, SUITE 130  
TEL: 949.387.4800, FAX: 949.347.0800

PROJECT IDENTIFICATION  
THIS DRAWING AND ALL INSTRUMENTS HEREBY REFERRED TO ARE THE PROPERTY OF IDS GROUP AND SHALL REMAIN THE PROPERTY OF IDS GROUP. NO PART OF THIS DRAWING OR INSTRUMENTS SHALL BE REPRODUCED OR TRANSMITTED IN ANY FORM OR BY ANY MEANS, ELECTRONIC OR MECHANICAL, INCLUDING PHOTOCOPYING, RECORDING, OR BY ANY INFORMATION STORAGE AND RETRIEVAL SYSTEM, WITHOUT THE WRITTEN PERMISSION OF IDS GROUP.

REVISIONS  
REV. DESCRIPTION DATE  
1.00 INITIALS BY DATE  
1.01 INITIALS BY DATE  
1.02 INITIALS BY DATE  
1.03 INITIALS BY DATE  
1.04 INITIALS BY DATE  
1.05 INITIALS BY DATE  
1.06 INITIALS BY DATE  
1.07 INITIALS BY DATE  
1.08 INITIALS BY DATE  
1.09 INITIALS BY DATE  
1.10 INITIALS BY DATE

PROJECT IDENTIFICATION  
THIS DRAWING AND ALL INSTRUMENTS HEREBY REFERRED TO ARE THE PROPERTY OF IDS GROUP AND SHALL REMAIN THE PROPERTY OF IDS GROUP. NO PART OF THIS DRAWING OR INSTRUMENTS SHALL BE REPRODUCED OR TRANSMITTED IN ANY FORM OR BY ANY MEANS, ELECTRONIC OR MECHANICAL, INCLUDING PHOTOCOPYING, RECORDING, OR BY ANY INFORMATION STORAGE AND RETRIEVAL SYSTEM, WITHOUT THE WRITTEN PERMISSION OF IDS GROUP.

IDS PROJECT NO. 23X117.00  
DRAWN BY [NAME]  
CHECKED BY [NAME]  
APPROVED BY [NAME]

SHEET NO. 28 OF 33  
FS-100  
FINISH SCHEDULE



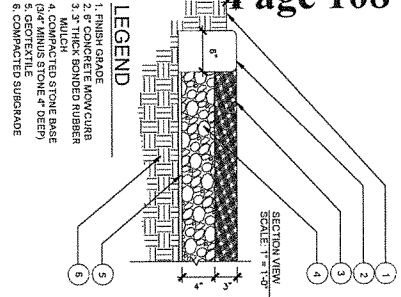

A BONDED RUBBER N.T.S.

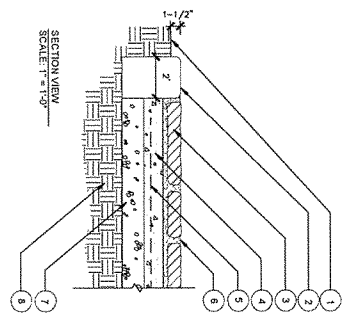

B FLAGSTONE PAVING N.T.S.

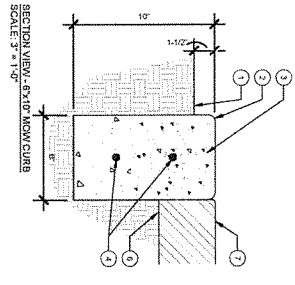

C CONCRETE MOW CURB N.T.S.

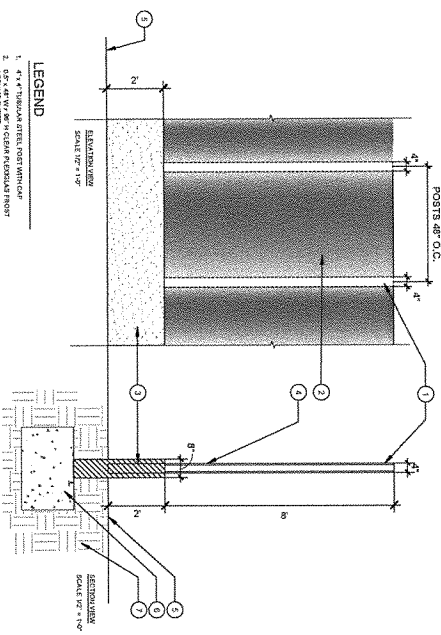

D DECORATIVE PANEL FENCE / PRIVACY WALL 3/4\"/>

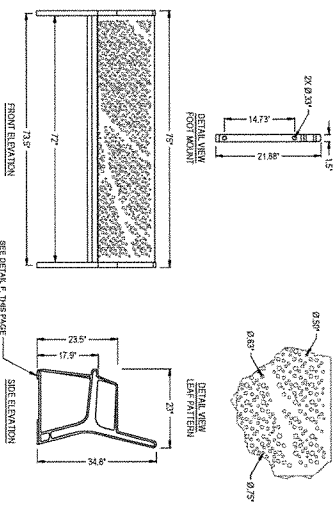

E BENCH 3/4\"/>

COLORS: SEAT - REYNOLDS BRONZE FRAME - BLACK  
 CONSTRUCTION: SEAT - 1/2\"/>

F CONCRETE FOOTING INSTALLATION UNDER FLAGSTONE 3/4\"/>

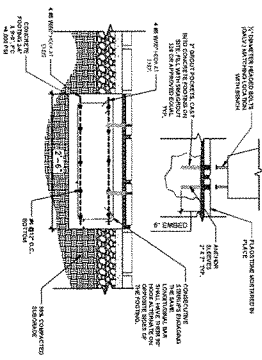

G CONCRETE FOOTING INSTALLATION UNDER FLAGSTONE 3/4\"/>

IDS GROUP - FILE LOCATION:

PLOT DATE:

USER:

<p>CLIENT: IDPO AND INTEREST AREA          411 E. CHAPMAN AVE. PLACENTIA, CA 92639</p>	<p>PROJECT NAME:  <b>OUTDOOR LIBRARY PATIO</b></p>	<p>411 E. CHAPMAN AVE.          PLACENTIA, CA 92639</p>	<p>IDS GROUP          1 PETERS CANYON ROAD, SUITE 130          TEL: 949-581-6500 FAX: 949-587-6800</p>		<p>DATE: 05/09/24</p>
					<p>REV: 05/09/24</p>
<p>PROJECT IDENTIFICATION</p> <p>THIS DRAWING IS A PART OF A PROJECT AND IS NOT TO BE REPRODUCED OR TRANSMITTED IN ANY FORM OR BY ANY MEANS, ELECTRONIC OR MECHANICAL, INCLUDING PHOTOCOPYING, RECORDING, OR BY ANY INFORMATION STORAGE AND RETRIEVAL SYSTEM.</p> <p>THE CONTRACTOR SHALL BE RESPONSIBLE FOR OBTAINING ALL NECESSARY PERMITS AND APPROVALS FROM THE LOCAL, STATE, AND FEDERAL AUTHORITIES.</p> <p>THE CONTRACTOR SHALL BE RESPONSIBLE FOR OBTAINING ALL NECESSARY PERMITS AND APPROVALS FROM THE LOCAL, STATE, AND FEDERAL AUTHORITIES.</p> <p>IDS PROJECT NO: 23X117.00</p> <p>DRAWN BY: RC</p> <p>CHECKED BY: AG</p> <p>APPROVED BY: JL</p>					
<p>SHEET TITLE:  <b>CONSTRUCTION DETAILS</b></p>					
<p>PREPARED BY:  <b>CD-100</b></p>					
<p>SHEET NO. 21 OF 33</p>					



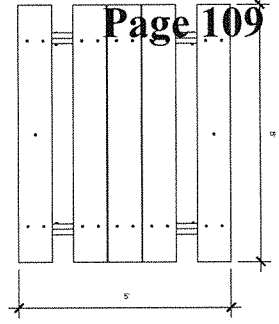

- NOTES:**
1. INSTALLATION TO BE COMPLETED IN ACCORDANCE WITH MANUFACTURER'S SPECIFICATIONS.
  2. DO NOT SCALE DRAWING.
  3. THIS DRAWING IS INTENDED FOR USE BY ARCHITECTS, ENGINEERS, CONTRACTORS, CONSULTANTS AND DESIGN PROFESSIONALS FOR PLANNING PURPOSES ONLY. THIS DRAWING MAY NOT BE USED FOR CONSTRUCTION.
  4. ALL INFORMATION CONTAINED HEREIN WAS CURRENT AND APPROVED BY THE PRODUCT MANUFACTURER TO BE CONSIDERED ACCURATE.
  5. SEE DETAIL C, THIS PAGE FOR CONCRETE FOOTING INSTALLATION.

**MATERIAL:**  
THE TABLE TOP AND 2 FLAT BENCH SEATS ARE MADE 2" X 10" (NOMINAL DIMENSIONS) RECYCLED PLASTIC PLANKS.  
TABLE TOP IS DESIGNED TO SUPPORT UP TO 100 LBS PER SQUARE FOOT. SEAT IS WILL SUPPORT UP TO 200 LBS. THE FRAMES ARE MADE OF RECYCLED PLASTIC PLANKS AND REINFORCED STEEL SUPPORTS.

**FEATURES:**  
THE FRAME IS PORTABLE IN DESIGN ALLOWING FOR FLEXIBILITY IN PLACEMENT. OPTIONAL HOLD DOWN KIT IS SOLD SEPARATELY.

**FINISH:**  
THE PLANKS ARE IMPERVIOUS TO MOISTURE AND CORROSION. DO NOT REQUIRE THE APPLICATION OF SEALANTS OR PRESERVATIVES AND WILL NEVER NEED PAINTING OR STAINING THROUGHOUT THE PRODUCT'S LIFE.

**ASSEMBLY:**  
THIS PRODUCT REQUIRES SOME ASSEMBLY. STAINLESS STEEL ASSEMBLY HARDWARE IS INCLUDED.

**COLOR:**  
SEE WEBSITE OR SALES REPRESENTATIVE FOR COLOR CHOICES.

**MAINTENANCE:**  
THE PRODUCT IS VIRTUALLY MAINTENANCE-FREE AND REQUIRES ONLY PERIODIC CLEANING WITH A SPONGE AND A SOLUTION OF MILD DETERGENT AND WATER TO REMOVE SURFACE DIRT. DO NOT CLEAN WITH SOLVENT OR PETROLEUM BASE PRODUCTS.

**WARRANTY:**  
20-YEAR LIMITED STRUCTURAL WARRANTY AND 20-YEAR WARRANTY ON RECYCLED PLASTIC FROM THE DATE OF PURCHASE.  
N.T.S.

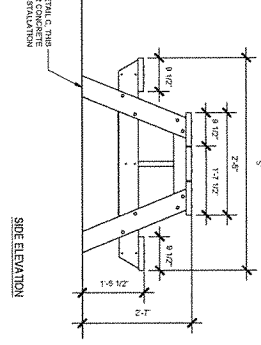
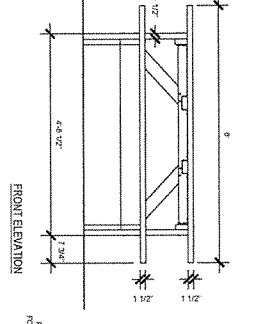

**MATERIAL:**  
THE PLANK CHAIR IS COMPOSED OF 4.81" X .75" POLYETHYLENE FRAME AND A .75" THICK CNC-CUT POLYETHYLENE FRAME, LEGS AND ARMRESTS. DESIGNED FOR RELAXATION, THE CHAIR FEATURES A 20" WIDE SEAT. OPTIONAL HOLD DOWN KIT IS AVAILABLE.

**FINISH:**  
POLYETHYLENE DOES NOT REQUIRE THE APPLICATION OF SEALANTS OR PRESERVATIVES AND WILL NEVER NEED PAINTING OR STAINING THROUGHOUT THE PRODUCT'S LIFE. FEATURES A UNIFORM COLOR THROUGHOUT AND A SCRATCH-RESISTANT SURFACE WITH UV INHIBITORS TO PROTECT AGAINST FADING.

**ASSEMBLY:**  
THE CHAIR REQUIRES SOME ASSEMBLY. THE BACKREST, SEAT AND SIDES SHIP PRE-ASSEMBLED. STAINLESS STEEL ASSEMBLY HARDWARE IS INCLUDED.

**COLOR:**  
SEE WEBSITE OR SALES REPRESENTATIVE FOR COLOR CHOICES.

**MAINTENANCE:**  
THE PRODUCT IS VIRTUALLY MAINTENANCE-FREE AND REQUIRES ONLY PERIODIC CLEANING WITH A SPONGE AND A SOLUTION OF MILD DETERGENT AND WATER TO REMOVE SURFACE DIRT. DO NOT CLEAN WITH SOLVENT OR PETROLEUM BASE PRODUCTS.

**WARRANTY:**  
20-YEAR LIMITED STRUCTURAL WARRANTY AND 20-YEAR WARRANTY ON RECYCLED PLASTIC FROM THE DATE OF PURCHASE.  
N.T.S.

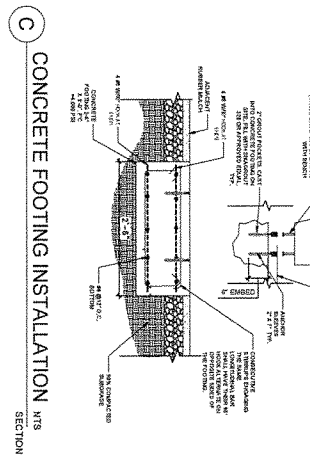

**NOTES:**

1. INSTALLATION TO BE COMPLETED IN ACCORDANCE WITH MANUFACTURER'S SPECIFICATIONS.
2. DO NOT SCALE DRAWING.
3. THIS DRAWING IS INTENDED FOR USE BY ARCHITECTS, ENGINEERS, CONTRACTORS, CONSULTANTS AND DESIGN PROFESSIONALS FOR PLANNING PURPOSES ONLY. THIS DRAWING MAY NOT BE USED FOR CONSTRUCTION.
4. ALL INFORMATION CONTAINED HEREIN WAS CURRENT AT THE TIME OF DEVELOPMENT BUT MUST BE REVIEWED AND APPROVED BY THE PRODUCT MANUFACTURER TO BE CONSIDERED ACCURATE.

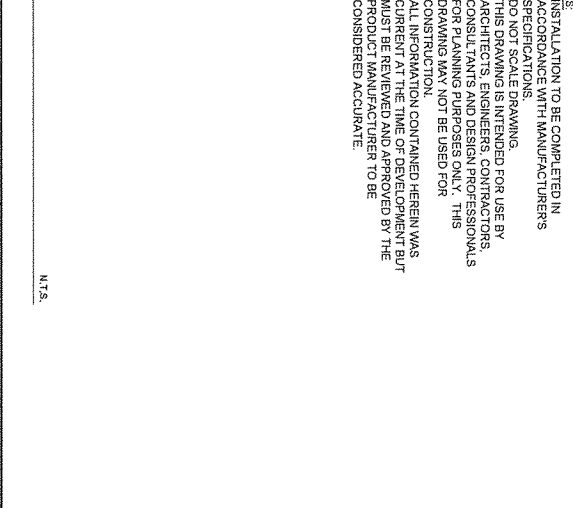
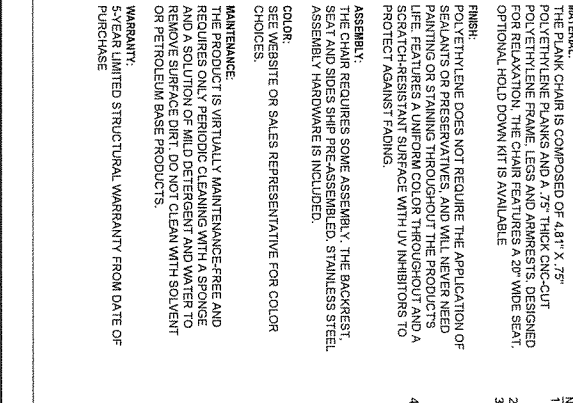
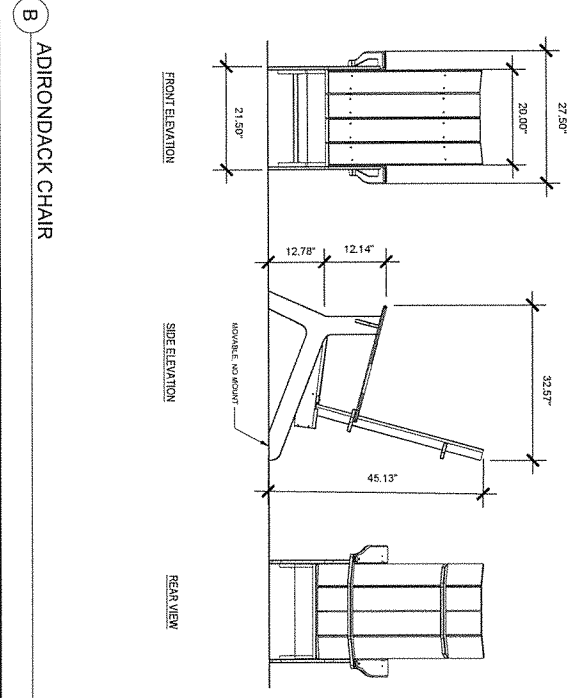

**MATERIAL:**  
THE PLANK CHAIR IS COMPOSED OF 4.81" X .75" POLYETHYLENE FRAME AND A .75" THICK CNC-CUT POLYETHYLENE FRAME, LEGS AND ARMRESTS. DESIGNED FOR RELAXATION, THE CHAIR FEATURES A 20" WIDE SEAT. OPTIONAL HOLD DOWN KIT IS AVAILABLE.

**FINISH:**  
POLYETHYLENE DOES NOT REQUIRE THE APPLICATION OF SEALANTS OR PRESERVATIVES AND WILL NEVER NEED PAINTING OR STAINING THROUGHOUT THE PRODUCT'S LIFE. FEATURES A UNIFORM COLOR THROUGHOUT AND A SCRATCH-RESISTANT SURFACE WITH UV INHIBITORS TO PROTECT AGAINST FADING.

**ASSEMBLY:**  
THE CHAIR REQUIRES SOME ASSEMBLY. THE BACKREST, SEAT AND SIDES SHIP PRE-ASSEMBLED. STAINLESS STEEL ASSEMBLY HARDWARE IS INCLUDED.

**COLOR:**  
SEE WEBSITE OR SALES REPRESENTATIVE FOR COLOR CHOICES.

**MAINTENANCE:**  
THE PRODUCT IS VIRTUALLY MAINTENANCE-FREE AND REQUIRES ONLY PERIODIC CLEANING WITH A SPONGE AND A SOLUTION OF MILD DETERGENT AND WATER TO REMOVE SURFACE DIRT. DO NOT CLEAN WITH SOLVENT OR PETROLEUM BASE PRODUCTS.

**WARRANTY:**  
20-YEAR LIMITED STRUCTURAL WARRANTY FROM DATE OF PURCHASE.  
N.T.S.

**PROJECT IDENTIFICATION**

THIS DRAWING WAS CREATED IN A PROJECT IDENTIFICATION SYSTEM BY THE USER. THE USER IS RESPONSIBLE FOR THE ACCURACY OF THE INFORMATION CONTAINED HEREIN. THE USER SHALL BE RESPONSIBLE FOR OBTAINING ALL NECESSARY PERMITS AND APPROVALS FROM ALL APPLICABLE AGENCIES AND AUTHORITIES.

**PROJECT IDENTIFICATION**

PROJECT NO. 23X117.00

DRAWN BY: NC

CHECKED BY: NC

APPROVED BY: J.

**SHEET TITLE**

CONSTRUCTION DETAILS

**SHEET NUMBER**

CD-101

**SHEET NO.** 22 OF 31

**CLIENT**

411 E. CHAPMAN AVE.  
PLACENTIA, CA 92679

**PROJECT NAME**

OUTDOOR LIBRARY PATIO

**CLIENT LOGO AND ADDRESS AREA**

411 E. CHAPMAN AVE.  
PLACENTIA, CA 92679

**placentia**  
LIBRARY DISTRICT

**IDS GROUP**

11 PETERS CANYON ROAD, SUITE 130  
TEL: 949-287-6500 FAX: 949-287-6500

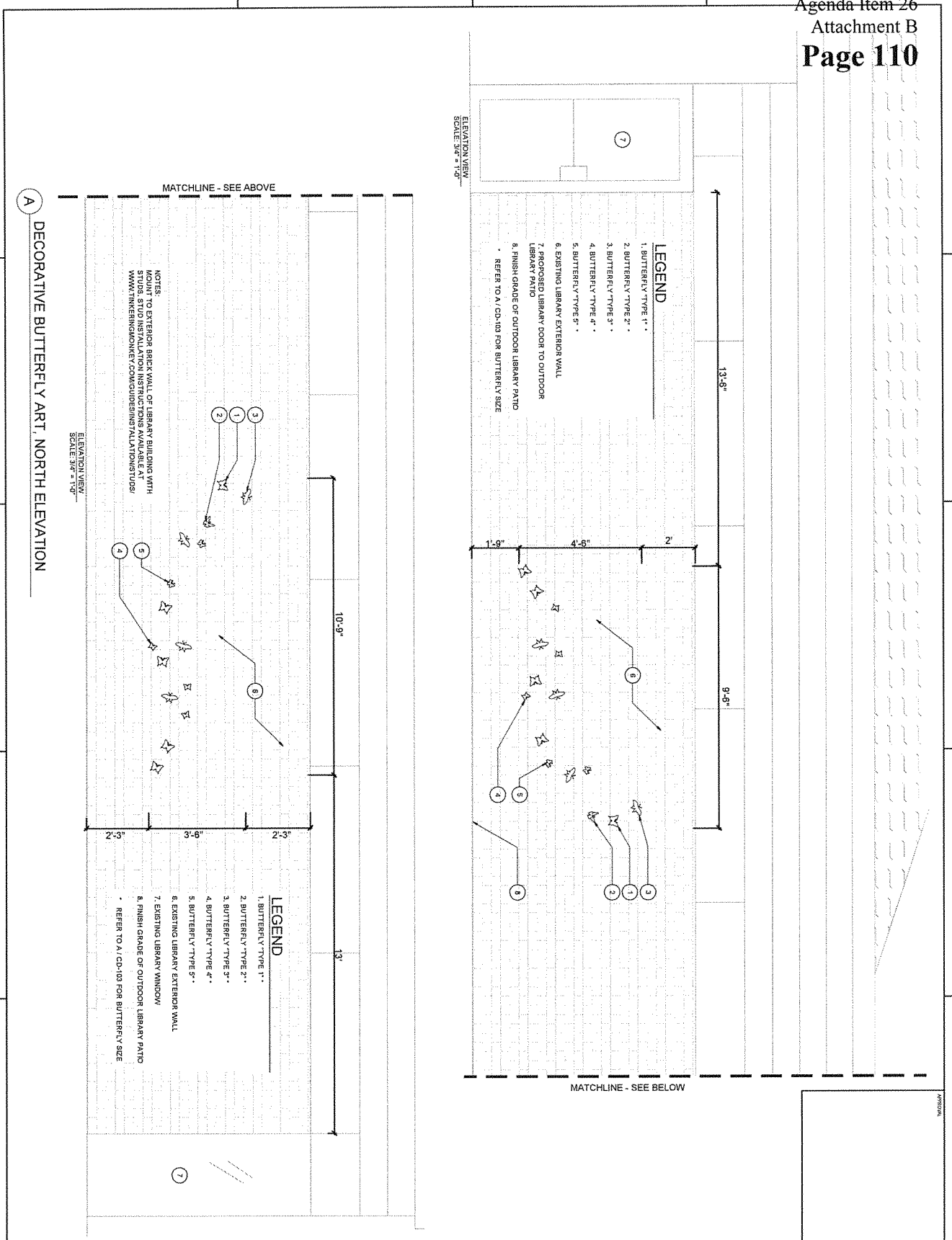

	CLIENT: IDS GROUP AND JOSEPH BEFA 411 E. CHAPMAN AVE. PLACENTIA, CA 92679
	PROJECT NAME: <b>OUTDOOR LIBRARY PATIO</b>
ADDRESS: 411 E. CHAPMAN AVE. PLACENTIA, CA 92679	
PROJECT ADDRESS: 1 PETERS CANYON ROAD, SUITE 130 TEL: 949-981-6500 FAX: 949-987-0000	
<b>PROJECT IDENTIFICATION</b> THIS DRAWING IS A PART OF A PROJECT AND NOT BE SEPARATED FROM THE PROJECT OR USED IN ANY OTHER PROJECT WITHOUT THE WRITTEN PERMISSION OF IDS GROUP. THE USER OF THIS DRAWING SHALL BE RESPONSIBLE FOR THE ACCURACY OF THE INFORMATION PROVIDED AND SHALL OBTAIN THE NECESSARY PERMITS FROM THE LOCAL AGENCIES.	SHEET NO. 29 OF 33
IDS PROJECT NO. 23X117.00 DRAWN BY: AS CHECKED BY: AS APPROVED BY: AS	SHEET NAME: <b>CONSTRUCTION DETAILS</b>
CD-102	SHEET NO. 29 OF 33

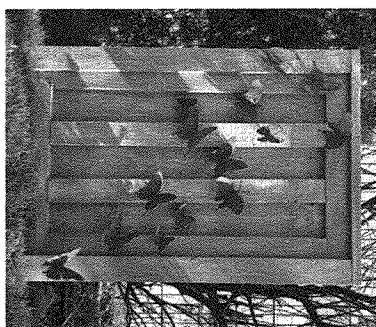
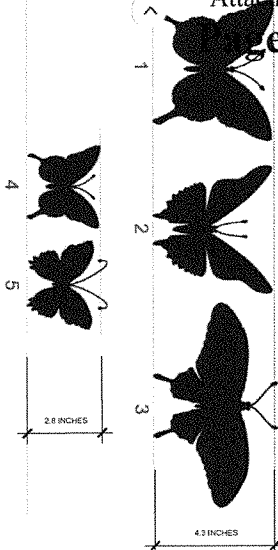

**A** BUTTERFLY ART DIMENSION

**B** DECORATIVE BUTTERFLY ART, EAST ELEVATION

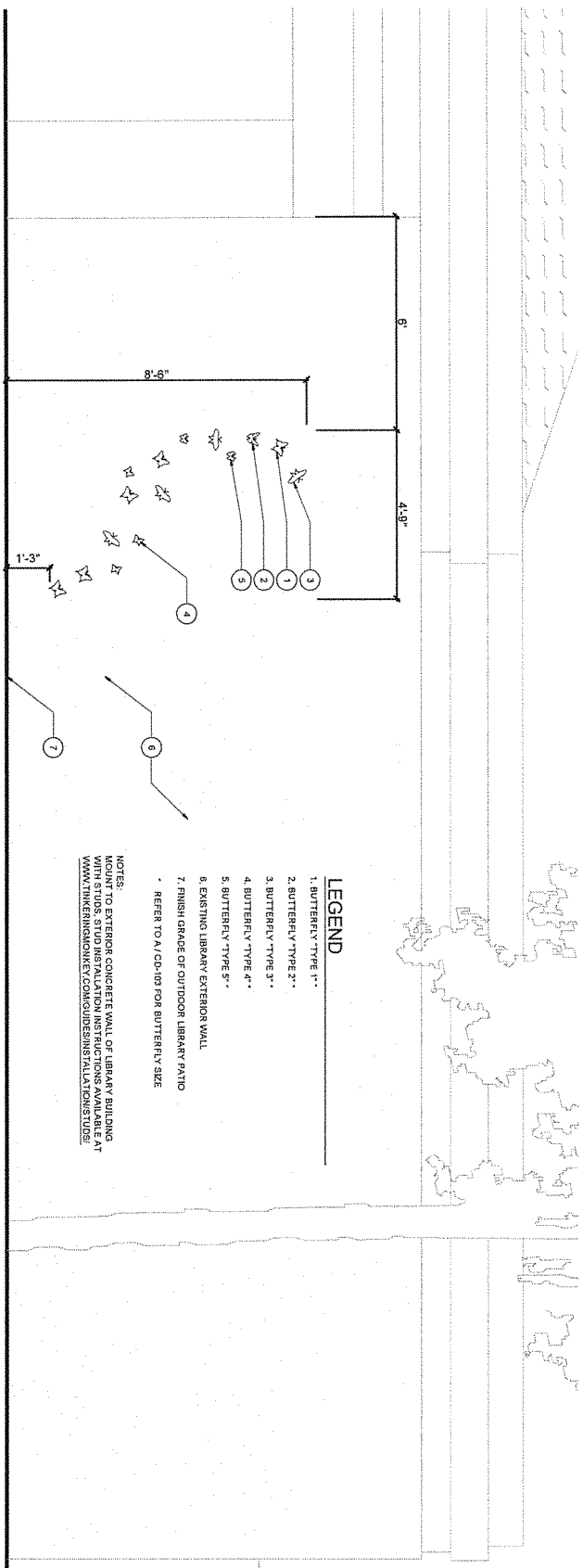

SECTION VIEW  
SCALE 3/4" = 1'-0"

**LEGEND**

- 1. BUTTERFLY TYPE 1\*\*
  - 2. BUTTERFLY TYPE 2\*\*
  - 3. BUTTERFLY TYPE 3\*\*
  - 4. BUTTERFLY TYPE 4\*\*
  - 5. BUTTERFLY TYPE 5\*\*
  - 6. EXISTING LIBRARY EXTERIOR WALL
  - 7. FINISH GRADE OF OUTDOOR LIBRARY PATIO
- \*\* REFER TO A CD-109 FOR BUTTERFLY SIZE

NOTES:  
MOUNT TO EXTERIOR CONCRETE WALL OF LIBRARY BUILDING WITH STUDS. STUD INSTALLATION INSTRUCTIONS AVAILABLE AT WWW.TINKERINGSKREY.COM/GUIDES/INSTALLATION/STUDS/

SHEET NUMBER  
**CD-103**

SHEET NO. 24 OF 53

**CONSTRUCTION DETAILS**

PROJECT IDENTIFICATION  
PROJECT NO. 231117-002

REV.	DESCRIPTION	DATE
1	POINTER'S SUBMITTAL	06/20/24
2	PLANKEN'S SUBMITTAL	06/20/24



**IDS GROUP**  
1 PETERS CANYON ROAD, SUITE 130  
IRVINE, CA 92606  
TEL: 949-387-4500 FAX: 949-387-4800

**OUTDOOR LIBRARY PATIO**  
411 E CHARMAN AVE  
PLACENTIA, CA 92870



DATE:

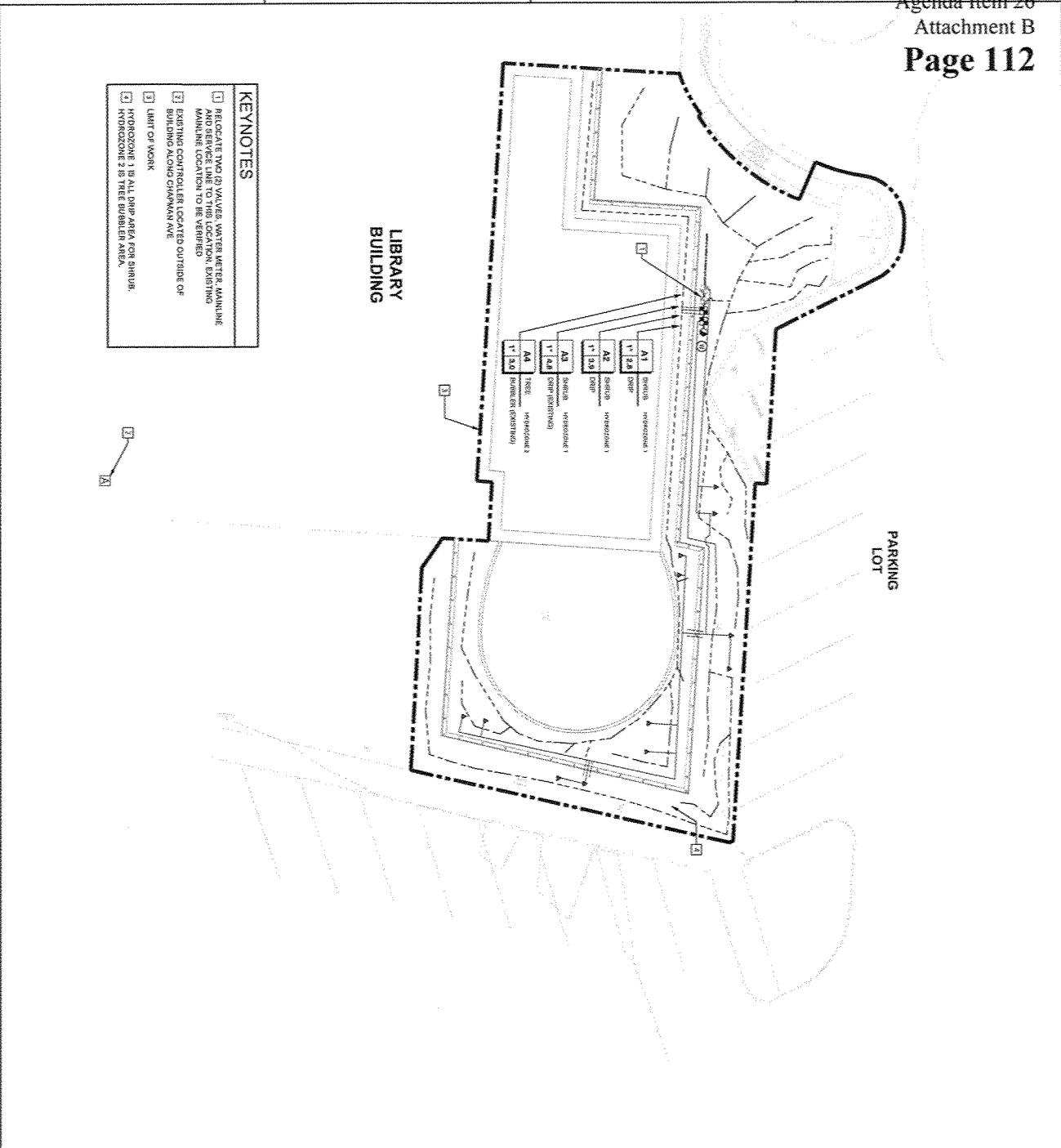

- KEYNOTES**
- 1 RISER VALVE (R) VALVE, WATER METER, MAINLINE MAINLINE LOCATION TO BE VERIFIED
  - 2 RISER CONTROLLER LOCATED OUTSIDE OF BUILDING AS SHOWN ON PLAN
  - 3 LIMIT OF WORK
  - 4 HYDRANT BOX 1 IS ALL DRIP AREA FOR SHRUBS, HYDRANT BOX 2 IS TREE BUBBLER AREA.

**SYMBOL LEGEND**

- EXISTING TREE VALVE (R) VALVE LOCATION
- EXISTING DRIP VALVE (R) VALVE LOCATION
- NEW DRIP VALVE
- ORBIT CONTROL - HANDED 4HP
- ESPINNO COMPRESSOR
- BUBBLER WATER METER (R) VALVE LOCATION
- NEW RISER VALVE - FIRE SERVICE
- EXISTING RISER VALVE - FIRE SERVICE
- PROPOSED MAINLINE FROM EXISTING 1"
- PROPOSED 1/2" RISER VALVE FOR PATIO, TRUCKED IN, 1/2" DRIP VALVE WITH 1/2" RISER CONNECTION WITH 1/2" MAINLINE, 40' x 10' x 10' IN SIZE
- PROPOSED 1/2" RISER VALVE FOR PATIO, TRUCKED IN, 1/2" DRIP VALVE WITH 1/2" RISER CONNECTION WITH 1/2" MAINLINE, 40' x 10' x 10' IN SIZE
- PROPOSED 1/2" RISER VALVE FOR PATIO, TRUCKED IN, 1/2" DRIP VALVE WITH 1/2" RISER CONNECTION WITH 1/2" MAINLINE, 40' x 10' x 10' IN SIZE
- PROPOSED 1/2" RISER VALVE FOR PATIO, TRUCKED IN, 1/2" DRIP VALVE WITH 1/2" RISER CONNECTION WITH 1/2" MAINLINE, 40' x 10' x 10' IN SIZE

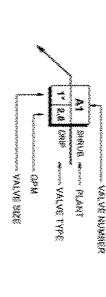

- IRRIGATION NOTES**
1. CONSULTATION TO BE REQUIRED FOR OBTAINING NECESSARY MAINLINE MAINLINE LOCATION TO BE VERIFIED
  2. RISER CONTROLLER LOCATED OUTSIDE OF BUILDING AS SHOWN ON PLAN
  3. LIMIT OF WORK
  4. HYDRANT BOX 1 IS ALL DRIP AREA FOR SHRUBS, HYDRANT BOX 2 IS TREE BUBBLER AREA.

SCALE: 1/8" = 1'-0"



411 E. CHAPMAN AVE.  
PLACENTIA, CA 92669

**OUTDOOR LIBRARY PATIO**

411 E. CHAPMAN AVE.  
PLACENTIA, CA 92669



1 FETTER CANYON ROAD, SUITE 100  
IRVINE, CA 92618  
TEL: 949-261-2500 FAX: 949-261-2800

REV.	DESCRIPTION	DATE
1	ISSUED FOR PERMIT	08/20/24
2	FOR CONSTRUCTION	08/20/24

**PROJECT IDENTIFICATION**

PROJECT NO. 23X11728

DRAWN BY: MC

CHECKED BY: MC

APPROVED BY: A

**IRRIGATION PLAN**

SHEET NO. 2 OF 3

**IR-100**

VALVE HEADSHEET LIST OF VALVANTS  
The number in bold face is the pipe diameter and is a minimum for the diameter of the pipe.  
Valve Headsheet (Landscaping Schedule)

Valve	Valve Type	Valve Size	Valve Material	Valve Location	Valve Notes
1	Ball Valve	1.5"	304 SS	Plant	1.5" SCH 40 PVC PIPE
2	Ball Valve	1.5"	304 SS	Plant	1.5" SCH 40 PVC PIPE
3	Ball Valve	1.5"	304 SS	Plant	1.5" SCH 40 PVC PIPE
4	Ball Valve	1.5"	304 SS	Plant	1.5" SCH 40 PVC PIPE
5	Ball Valve	1.5"	304 SS	Plant	1.5" SCH 40 PVC PIPE
6	Ball Valve	1.5"	304 SS	Plant	1.5" SCH 40 PVC PIPE
7	Ball Valve	1.5"	304 SS	Plant	1.5" SCH 40 PVC PIPE
8	Ball Valve	1.5"	304 SS	Plant	1.5" SCH 40 PVC PIPE
9	Ball Valve	1.5"	304 SS	Plant	1.5" SCH 40 PVC PIPE
10	Ball Valve	1.5"	304 SS	Plant	1.5" SCH 40 PVC PIPE
11	Ball Valve	1.5"	304 SS	Plant	1.5" SCH 40 PVC PIPE
12	Ball Valve	1.5"	304 SS	Plant	1.5" SCH 40 PVC PIPE
13	Ball Valve	1.5"	304 SS	Plant	1.5" SCH 40 PVC PIPE
14	Ball Valve	1.5"	304 SS	Plant	1.5" SCH 40 PVC PIPE
15	Ball Valve	1.5"	304 SS	Plant	1.5" SCH 40 PVC PIPE
16	Ball Valve	1.5"	304 SS	Plant	1.5" SCH 40 PVC PIPE
17	Ball Valve	1.5"	304 SS	Plant	1.5" SCH 40 PVC PIPE
18	Ball Valve	1.5"	304 SS	Plant	1.5" SCH 40 PVC PIPE
19	Ball Valve	1.5"	304 SS	Plant	1.5" SCH 40 PVC PIPE
20	Ball Valve	1.5"	304 SS	Plant	1.5" SCH 40 PVC PIPE
21	Ball Valve	1.5"	304 SS	Plant	1.5" SCH 40 PVC PIPE
22	Ball Valve	1.5"	304 SS	Plant	1.5" SCH 40 PVC PIPE
23	Ball Valve	1.5"	304 SS	Plant	1.5" SCH 40 PVC PIPE
24	Ball Valve	1.5"	304 SS	Plant	1.5" SCH 40 PVC PIPE
25	Ball Valve	1.5"	304 SS	Plant	1.5" SCH 40 PVC PIPE
26	Ball Valve	1.5"	304 SS	Plant	1.5" SCH 40 PVC PIPE
27	Ball Valve	1.5"	304 SS	Plant	1.5" SCH 40 PVC PIPE
28	Ball Valve	1.5"	304 SS	Plant	1.5" SCH 40 PVC PIPE
29	Ball Valve	1.5"	304 SS	Plant	1.5" SCH 40 PVC PIPE
30	Ball Valve	1.5"	304 SS	Plant	1.5" SCH 40 PVC PIPE
31	Ball Valve	1.5"	304 SS	Plant	1.5" SCH 40 PVC PIPE
32	Ball Valve	1.5"	304 SS	Plant	1.5" SCH 40 PVC PIPE
33	Ball Valve	1.5"	304 SS	Plant	1.5" SCH 40 PVC PIPE
34	Ball Valve	1.5"	304 SS	Plant	1.5" SCH 40 PVC PIPE
35	Ball Valve	1.5"	304 SS	Plant	1.5" SCH 40 PVC PIPE
36	Ball Valve	1.5"	304 SS	Plant	1.5" SCH 40 PVC PIPE
37	Ball Valve	1.5"	304 SS	Plant	1.5" SCH 40 PVC PIPE
38	Ball Valve	1.5"	304 SS	Plant	1.5" SCH 40 PVC PIPE
39	Ball Valve	1.5"	304 SS	Plant	1.5" SCH 40 PVC PIPE
40	Ball Valve	1.5"	304 SS	Plant	1.5" SCH 40 PVC PIPE
41	Ball Valve	1.5"	304 SS	Plant	1.5" SCH 40 PVC PIPE
42	Ball Valve	1.5"	304 SS	Plant	1.5" SCH 40 PVC PIPE
43	Ball Valve	1.5"	304 SS	Plant	1.5" SCH 40 PVC PIPE
44	Ball Valve	1.5"	304 SS	Plant	1.5" SCH 40 PVC PIPE
45	Ball Valve	1.5"	304 SS	Plant	1.5" SCH 40 PVC PIPE
46	Ball Valve	1.5"	304 SS	Plant	1.5" SCH 40 PVC PIPE
47	Ball Valve	1.5"	304 SS	Plant	1.5" SCH 40 PVC PIPE
48	Ball Valve	1.5"	304 SS	Plant	1.5" SCH 40 PVC PIPE
49	Ball Valve	1.5"	304 SS	Plant	1.5" SCH 40 PVC PIPE
50	Ball Valve	1.5"	304 SS	Plant	1.5" SCH 40 PVC PIPE
51	Ball Valve	1.5"	304 SS	Plant	1.5" SCH 40 PVC PIPE
52	Ball Valve	1.5"	304 SS	Plant	1.5" SCH 40 PVC PIPE
53	Ball Valve	1.5"	304 SS	Plant	1.5" SCH 40 PVC PIPE
54	Ball Valve	1.5"	304 SS	Plant	1.5" SCH 40 PVC PIPE
55	Ball Valve	1.5"	304 SS	Plant	1.5" SCH 40 PVC PIPE
56	Ball Valve	1.5"	304 SS	Plant	1.5" SCH 40 PVC PIPE
57	Ball Valve	1.5"	304 SS	Plant	1.5" SCH 40 PVC PIPE
58	Ball Valve	1.5"	304 SS	Plant	1.5" SCH 40 PVC PIPE
59	Ball Valve	1.5"	304 SS	Plant	1.5" SCH 40 PVC PIPE
60	Ball Valve	1.5"	304 SS	Plant	1.5" SCH 40 PVC PIPE
61	Ball Valve	1.5"	304 SS	Plant	1.5" SCH 40 PVC PIPE
62	Ball Valve	1.5"	304 SS	Plant	1.5" SCH 40 PVC PIPE
63	Ball Valve	1.5"	304 SS	Plant	1.5" SCH 40 PVC PIPE
64	Ball Valve	1.5"	304 SS	Plant	1.5" SCH 40 PVC PIPE
65	Ball Valve	1.5"	304 SS	Plant	1.5" SCH 40 PVC PIPE
66	Ball Valve	1.5"	304 SS	Plant	1.5" SCH 40 PVC PIPE
67	Ball Valve	1.5"	304 SS	Plant	1.5" SCH 40 PVC PIPE
68	Ball Valve	1.5"	304 SS	Plant	1.5" SCH 40 PVC PIPE
69	Ball Valve	1.5"	304 SS	Plant	1.5" SCH 40 PVC PIPE
70	Ball Valve	1.5"	304 SS	Plant	1.5" SCH 40 PVC PIPE
71	Ball Valve	1.5"	304 SS	Plant	1.5" SCH 40 PVC PIPE
72	Ball Valve	1.5"	304 SS	Plant	1.5" SCH 40 PVC PIPE
73	Ball Valve	1.5"	304 SS	Plant	1.5" SCH 40 PVC PIPE
74	Ball Valve	1.5"	304 SS	Plant	1.5" SCH 40 PVC PIPE
75	Ball Valve	1.5"	304 SS	Plant	1.5" SCH 40 PVC PIPE
76	Ball Valve	1.5"	304 SS	Plant	1.5" SCH 40 PVC PIPE
77	Ball Valve	1.5"	304 SS	Plant	1.5" SCH 40 PVC PIPE
78	Ball Valve	1.5"	304 SS	Plant	1.5" SCH 40 PVC PIPE
79	Ball Valve	1.5"	304 SS	Plant	1.5" SCH 40 PVC PIPE
80	Ball Valve	1.5"	304 SS	Plant	1.5" SCH 40 PVC PIPE
81	Ball Valve	1.5"	304 SS	Plant	1.5" SCH 40 PVC PIPE
82	Ball Valve	1.5"	304 SS	Plant	1.5" SCH 40 PVC PIPE
83	Ball Valve	1.5"	304 SS	Plant	1.5" SCH 40 PVC PIPE
84	Ball Valve	1.5"	304 SS	Plant	1.5" SCH 40 PVC PIPE
85	Ball Valve	1.5"	304 SS	Plant	1.5" SCH 40 PVC PIPE
86	Ball Valve	1.5"	304 SS	Plant	1.5" SCH 40 PVC PIPE
87	Ball Valve	1.5"	304 SS	Plant	1.5" SCH 40 PVC PIPE
88	Ball Valve	1.5"	304 SS	Plant	1.5" SCH 40 PVC PIPE
89	Ball Valve	1.5"	304 SS	Plant	1.5" SCH 40 PVC PIPE
90	Ball Valve	1.5"	304 SS	Plant	1.5" SCH 40 PVC PIPE
91	Ball Valve	1.5"	304 SS	Plant	1.5" SCH 40 PVC PIPE
92	Ball Valve	1.5"	304 SS	Plant	1.5" SCH 40 PVC PIPE
93	Ball Valve	1.5"	304 SS	Plant	1.5" SCH 40 PVC PIPE
94	Ball Valve	1.5"	304 SS	Plant	1.5" SCH 40 PVC PIPE
95	Ball Valve	1.5"	304 SS	Plant	1.5" SCH 40 PVC PIPE
96	Ball Valve	1.5"	304 SS	Plant	1.5" SCH 40 PVC PIPE
97	Ball Valve	1.5"	304 SS	Plant	1.5" SCH 40 PVC PIPE
98	Ball Valve	1.5"	304 SS	Plant	1.5" SCH 40 PVC PIPE
99	Ball Valve	1.5"	304 SS	Plant	1.5" SCH 40 PVC PIPE
100	Ball Valve	1.5"	304 SS	Plant	1.5" SCH 40 PVC PIPE

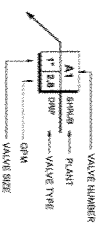

PIPE SIZING CHART

Flow Rate (GPM)	Minimum Pipe Size (PVC)	Maximum Pipe Size (PVC)
0-17 GPM	1/2" SCH 40 PVC PIPE	1/2" SCH 40 PVC PIPE
7-26 GPM	1/2" SCH 40 PVC PIPE	1/2" SCH 40 PVC PIPE
13-22 GPM	1/2" SCH 40 PVC PIPE	1/2" SCH 40 PVC PIPE
22-30 GPM	1/2" SCH 40 PVC PIPE	1/2" SCH 40 PVC PIPE
30-30 GPM	1/2" SCH 40 PVC PIPE	1/2" SCH 40 PVC PIPE

NOTE:  
CONNECTION SHALL BE ALL LATERAL LINES PER PIPE SIZING RANGE.  
IN NO INSTANCE SHALL PIPE SIZE EXCEED DESIGNATED GPM RANGE.

IRRIGATION MATERIAL LEGEND

SYMBOL	MANUFACT	MODEL NO./DESCRIPTION	GPM	IN
▲	RAIN BIRD	RWB-C-101 W/IRRS-SOCK	0.25	30
●	HUNTER	HUNTER DRIFTLINE, HDL-09-12-PC, WITH 12" EXITTER SPRINKLER (MAX. 20' FT. OF DRIFTLINE)	0.9	30
□	HUNTER	DRIP VALVE (CZ-10)		
○	HUNTER	QUICK CONNECT AMP		
⊠	HUNTER	EXISTING CONTROLLER		
—	AS APPROVED	IRRIGATION MAINLINE: 4" CLASS 315 MAINLINE		
—	AS APPROVED	ALL BRANCHED FITTINGS SHALL BE SCH 40 PVC.		
—	AS APPROVED	IRRIGATION LATERAL LINE: PVC SCH 40 PVC SCH 40 IRRIGATION PIPE ONLY LATERAL TRANSITION PIPE SIZES 1" AND ABOVE ARE INDICATED ON THE PLAN WITH ALL OTHERS BEING 1/2" IN SIZE.		
—	AS APPROVED	PVC PIPE SCH 40 AS SLEEVING, TWICE THE DIAMETER OF PIPE OR WIRE BUNDLE CARRIED PLACE BELOW ALL PAVING, HARDSCAPE, ETC. AND AS DIRECTED BY OWNER'S AUTHORIZED REPRESENTATIVE.		



411 E. CHAPMAN AVE.  
PLACENTIA, CA 92870  
PROJECT NAME  
OUTDOOR LIBRARY PATIO

IDS GROUP  
1 FLETCHER CANYON ROAD, SUITE 130  
IRVINE, CA 92618  
TEL: 949-251-9800, FAX: 949-251-2400



REV.	DESCRIPTION	DATE
1	ISSUED FOR PERMIT	06/20/24
2	REVISED PER COMMENTS	06/20/24

PROJECT IDENTIFICATION  
PROJECT NO. 23X117.00  
JOB PROJECT NO. 23X117.00  
DRAWN BY: NC  
CHECKED BY: MD  
APPROVED BY: A

IRRIGATION LEGEND & CALCULATION  
ID-100  
SHEET NO. 36 OF 33

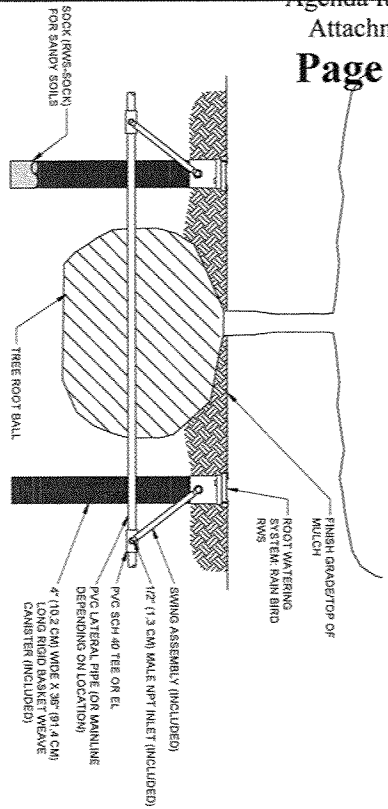

- NOTES:
1. POSITION UNITS EVENLY SPACED AROUND PLANT PER IRRIGATION PLAN LEGEND. NEAR ROOT BALL, FOR EXISTING TREES PLACE HALF THE DISTANCE BETWEEN CANOPY EDGE AND TREE TRUNK.
  2. INSTALL PRODUCT WITH TOP EVEN WITH GROUND SURFACE.
  3. WHEN INSTALLING IN EXTREMELY HARD OR CLAY SOILS, ADD 3/4\"/>

1 ROOT WATERING SYSTEM (B-1401)

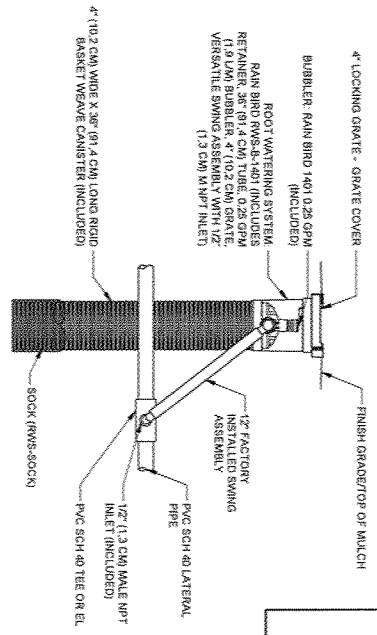

- NOTES:
1. 4\"/>

2 ROOT WATERING SYSTEM (B-1401)

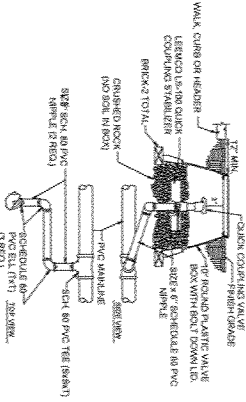
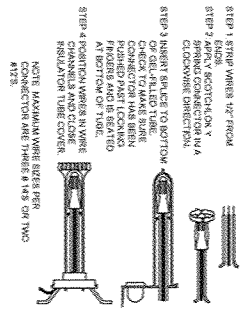

3 WIRE CONNECTION DETAIL

4 QUICK COUPLER IN BOX DETAIL

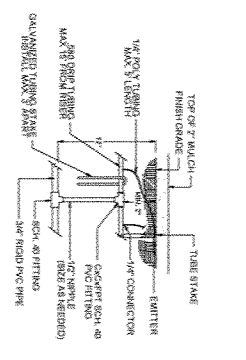

5 RISER TO DRIP TUBING DETAIL

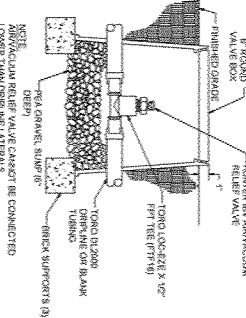

6 AIR/VACUUM RELIEF VALVE



CLARK GOSWAMIS CENTER AREA  
411 E. CHAMMAYUE  
PLACENCIA, CA 92679

OUTDOOR LIBRARY  
PATIO



1 PETER GARDEN ROAD, SUITE 100  
IRVINE, CA 92618  
TEL: 949-251-9550, FAX: 949-251-9488



REV.	DESCRIPTION	DATE
1	ISSUED FOR PERMITS	09/20/04
2	PLAN CHECK SUBMITTAL	09/20/04

PROJECT IDENTIFICATION

PROJECT NO. 23X117.00

DRAWN BY: EC

CHECKED BY: MS

APPROVED BY: JL

SHEET NO. 17 OF 33

PROJECT NAME: ID-101

IRRIGATION DETAILS

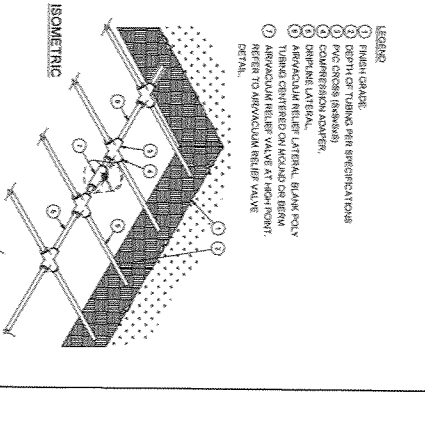
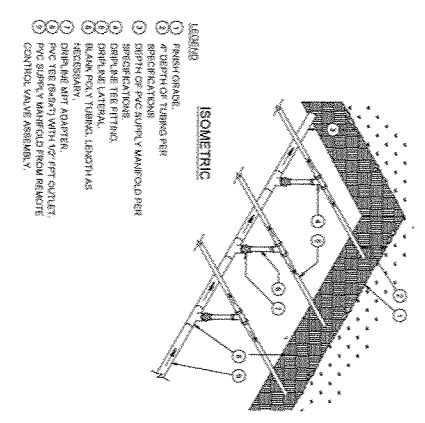
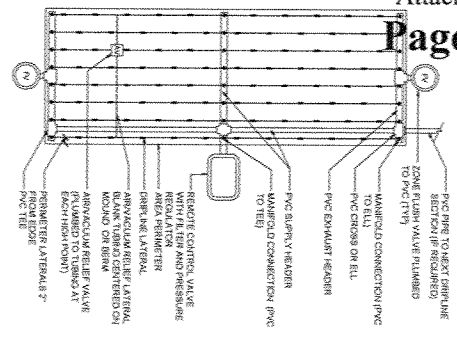

1 IN-LINE DRIP CIRCUIT LAYOUT

2 CENTER FEED MANIFOLD

3 AIR/VACUUM RELIEF LATERAL

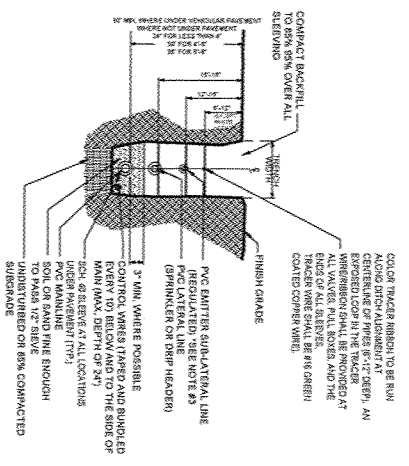

4 IRRIGATION TRENCHING

5 REMOTE CONTROL VALVE

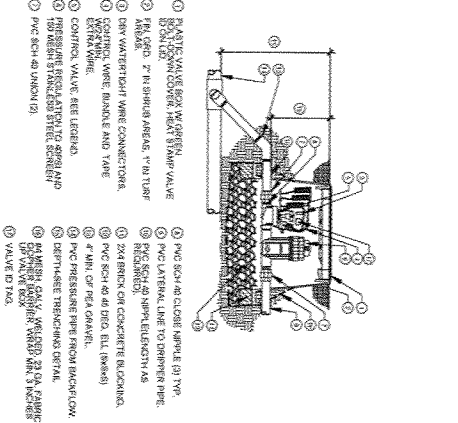

6 AIR/VACUUM RELIEF LATERAL

IDS GROUP  
411 E. GUANAJUATE  
PACERITA, CA 92570

CLIENT: 1000 AGRI-RESERVE AREA  
1111 CAMPANILE PLACERITA, CA 92570

PROJECT NAME:  
OUTDOOR LIBRARY  
PATIO

1 HERBES CANYON ROAD, SUITE 130  
IRVINE, CA 92618  
TEL: 949.381-4850 FAX: 949.381-4860

NO.	DESCRIPTION	DATE
01	PLACERITA SUBMITTAL	09/20/09
02	FINAL CHECK SUBMITTAL	09/20/09

PROJECT IDENTIFICATION  
THIS DRAWING AND ALL TECHNICAL INFORMATION HEREON SHALL BE THE PROPERTY OF IDS GROUP. NO PART OF THIS DRAWING OR ANY INFORMATION CONTAINED HEREIN SHALL BE REPRODUCED OR TRANSMITTED IN ANY FORM OR BY ANY MEANS, ELECTRONIC OR MECHANICAL, INCLUDING PHOTOCOPYING, RECORDING, OR BY ANY INFORMATION STORAGE AND RETRIEVAL SYSTEM, WITHOUT THE WRITTEN PERMISSION OF IDS GROUP.

ISSUED PROJECT NO.: 234711-001  
DRAWN BY: HC  
CHECKED BY: HC  
APPROVED BY: A

SHEET TITLE:  
IRRIGATION  
DETAILS

SHEET NUMBER:  
ID-102

SHEET NO. 26 OF 33

IDS GROUP - FILE LOCATION: PLOT DATE: USER:

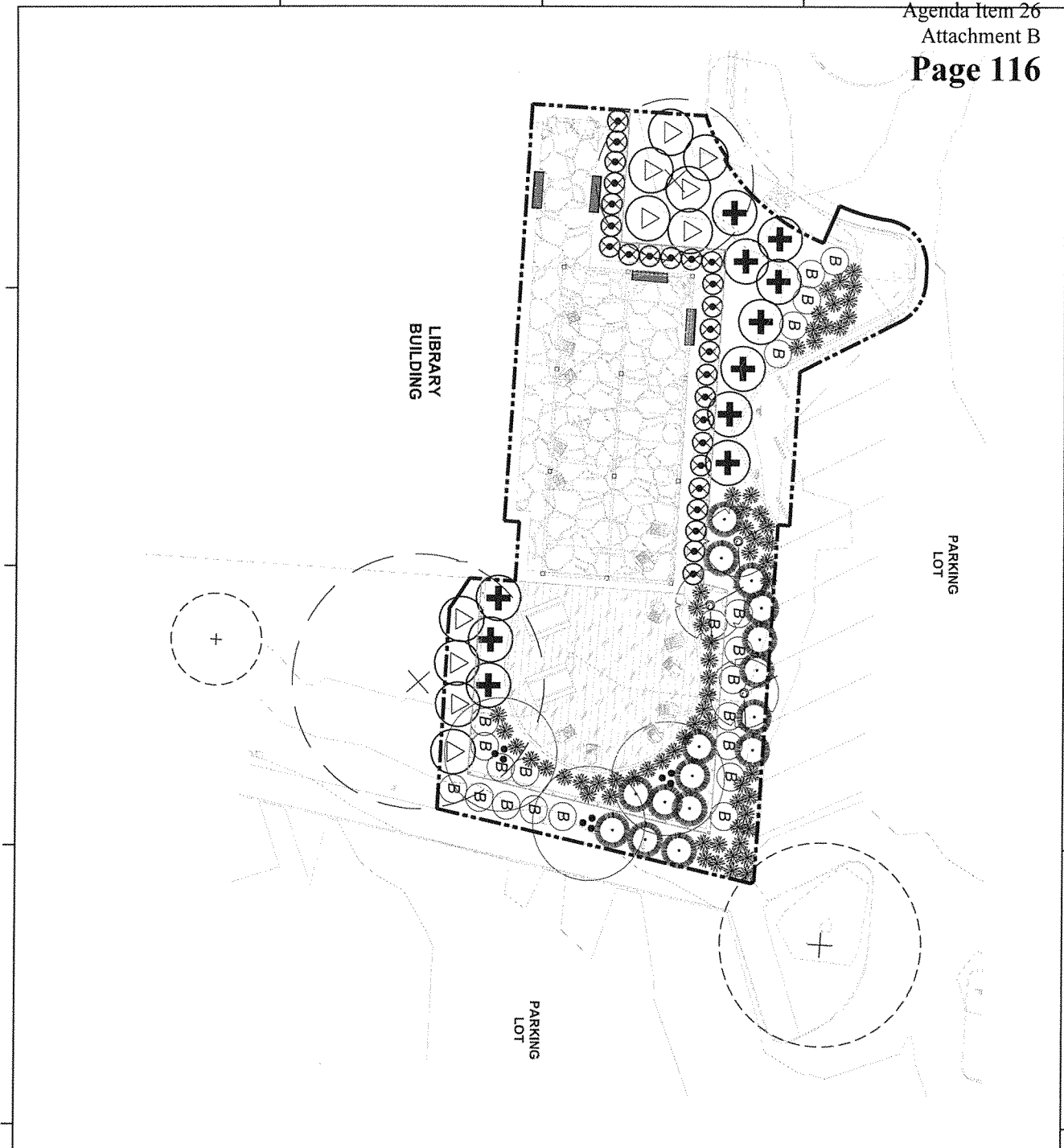

**TREE PLANTING LEGEND**

SYMBOL	SYMBOL NAME	QUANTITY	SIZE
(+)	Large trees	1	24" DIA.
(B)	Small trees	14	24" DIA.
(X)	Small trees to be removed	1	24" DIA.
(△)	Small trees to be removed	1	24" DIA.

**SHRUB PLANTING LEGEND**

SYMBOL	SYMBOL NAME	QUANTITY	SIZE
(+)	Small shrubs	1	12" DIA.
(B)	Small shrubs	14	12" DIA.
(X)	Small shrubs to be removed	1	12" DIA.
(△)	Small shrubs to be removed	1	12" DIA.

SCALE : 1/8" = 1' - 0"

	CLIENT: LOS ANGELES AREA 411 E. CANYON AVE. PASADENA, CA 92319
	PROJECT NAME: <b>OUTDOOR LIBRARY PATIO</b>
411 E. CANYON AVE. PASADENA, CA 92309	ARCHITECT: <b>IDS GROUP</b> 1 FETTER CANYON ROAD, SUITE 130 PASADENA, CA 92306 TEL: 818-797-8500 FAX: 818-797-2800
SHEET NUMBER: <b>PL-100</b>	SHEET NO. 29 OF 33



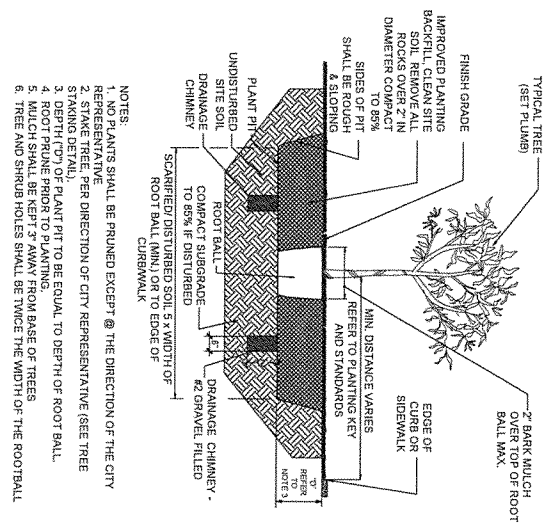

**A** TREE PLANTING DETAIL  
N.T.S.  
SECTION

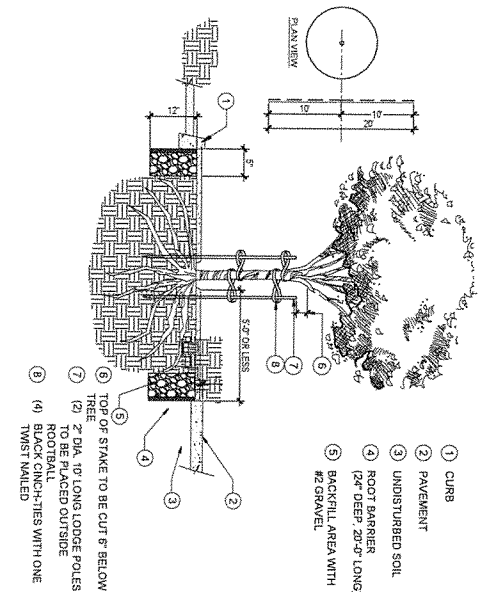

**B** TREE PLANTING STAKING & ROOT BARRIER  
N.T.S.  
SECTION

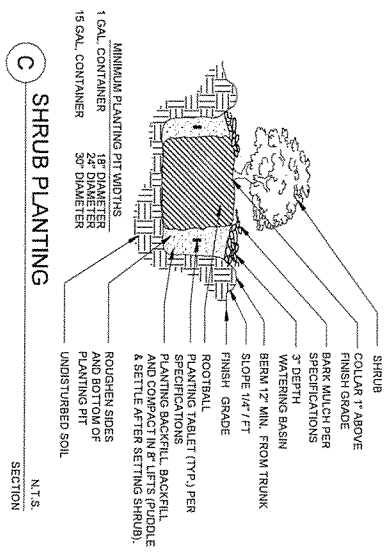

**C** SHRUB PLANTING  
N.T.S.  
SECTION

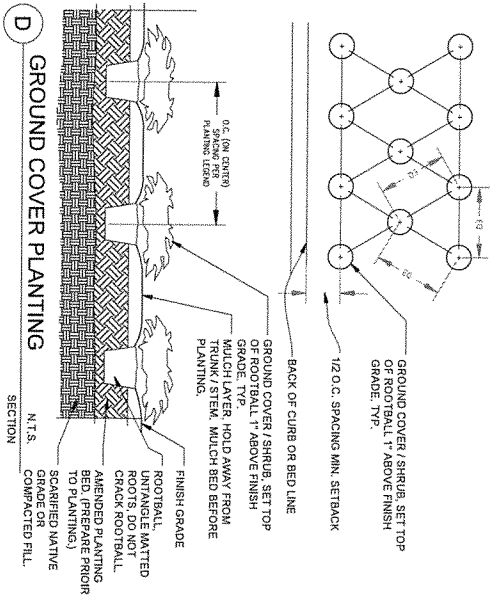

**D** GROUND COVER PLANTING  
N.T.S.  
SECTION

CLIENT LOGO AND ADDRESS AREA  
411 E CHURCHMAN AVE  
PLACENTIA, CA 92669

PROJECT NAME  
**OUTDOOR LIBRARY PATIO**

DESIGNER/ARCHITECT  
**IDS GROUP**  
1 PETERS CANYON ROAD, SUITE 100  
IRVINE, CA 92618  
TEL: 949-387-7830, FAX: 949-387-0860

REV	DESCRIPTION	DATE
1	FINAL CHECK SUBMITTAL	06/01/20
2	FINAL CHECK SUBMITTAL	06/22/20

**PROJECT IDENTIFICATION**  
THE DRAWING IS TO BE USED IN ACCORDANCE WITH THE AIA DOCUMENT B191 - STANDARD FORM OF CONTRACT BETWEEN ARCHITECT AND CONTRACTOR. THE CONTRACTOR SHALL BE RESPONSIBLE FOR THE PROTECTION AND CONSERVATION OF THE EXISTING AND ADJACENT UTILITIES AND STRUCTURES. THE CONTRACTOR SHALL BE RESPONSIBLE FOR THE PROTECTION AND CONSERVATION OF THE EXISTING AND ADJACENT UTILITIES AND STRUCTURES. THE CONTRACTOR SHALL BE RESPONSIBLE FOR THE PROTECTION AND CONSERVATION OF THE EXISTING AND ADJACENT UTILITIES AND STRUCTURES.

**IDS PROJECT NO.** 23X117100  
**DRAWN BY** RC  
**CHECKED BY** NS  
**APPROVED BY** A

**SHEET TITLE**  
**PLANTING DETAILS**

**SHEET NUMBER**  
**PD-100**

**SHEET NO.** 30 **OF** 53

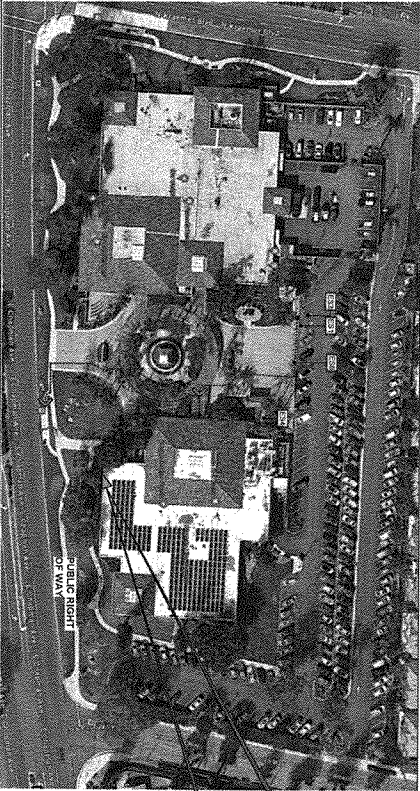

ACCESSIBLE ROUTE TO PUBLIC RIGHT OF WAY AND ADDRESS LOCATION

NOT TO SCALE

1

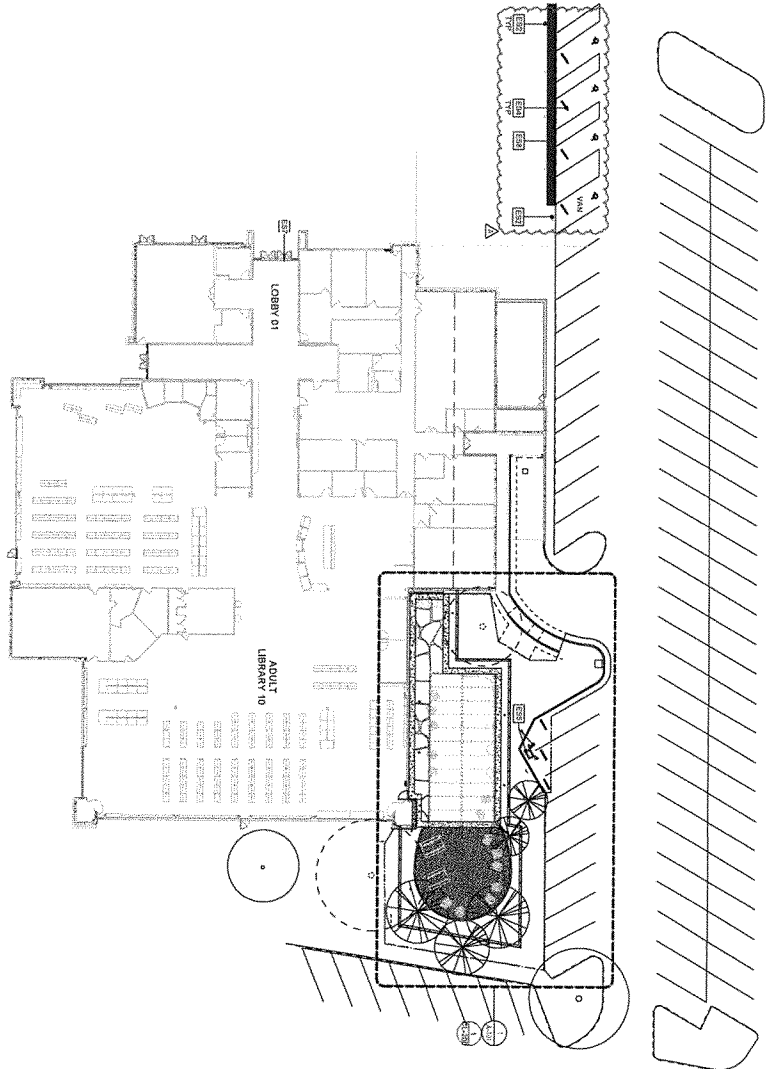

OVERALL SITE PLAN

1" = 20'-0"

2

KEYNOTES

VALUE	DESCRIPTION
1	EXISTING EXTERIOR SIGNAGE
2	EXISTING EXTERIOR SIGNAGE
3	EXISTING EXTERIOR SIGNAGE
4	EXISTING EXTERIOR SIGNAGE
5	EXISTING EXTERIOR SIGNAGE
6	EXISTING EXTERIOR SIGNAGE
7	EXISTING EXTERIOR SIGNAGE
8	EXISTING EXTERIOR SIGNAGE
9	EXISTING EXTERIOR SIGNAGE
10	EXISTING EXTERIOR SIGNAGE
11	EXISTING EXTERIOR SIGNAGE
12	EXISTING EXTERIOR SIGNAGE
13	EXISTING EXTERIOR SIGNAGE
14	EXISTING EXTERIOR SIGNAGE
15	EXISTING EXTERIOR SIGNAGE
16	EXISTING EXTERIOR SIGNAGE
17	EXISTING EXTERIOR SIGNAGE
18	EXISTING EXTERIOR SIGNAGE
19	EXISTING EXTERIOR SIGNAGE
20	EXISTING EXTERIOR SIGNAGE
21	EXISTING EXTERIOR SIGNAGE
22	EXISTING EXTERIOR SIGNAGE
23	EXISTING EXTERIOR SIGNAGE
24	EXISTING EXTERIOR SIGNAGE
25	EXISTING EXTERIOR SIGNAGE
26	EXISTING EXTERIOR SIGNAGE
27	EXISTING EXTERIOR SIGNAGE
28	EXISTING EXTERIOR SIGNAGE
29	EXISTING EXTERIOR SIGNAGE
30	EXISTING EXTERIOR SIGNAGE
31	EXISTING EXTERIOR SIGNAGE
32	EXISTING EXTERIOR SIGNAGE
33	EXISTING EXTERIOR SIGNAGE
34	EXISTING EXTERIOR SIGNAGE
35	EXISTING EXTERIOR SIGNAGE
36	EXISTING EXTERIOR SIGNAGE
37	EXISTING EXTERIOR SIGNAGE
38	EXISTING EXTERIOR SIGNAGE
39	EXISTING EXTERIOR SIGNAGE
40	EXISTING EXTERIOR SIGNAGE
41	EXISTING EXTERIOR SIGNAGE
42	EXISTING EXTERIOR SIGNAGE
43	EXISTING EXTERIOR SIGNAGE
44	EXISTING EXTERIOR SIGNAGE
45	EXISTING EXTERIOR SIGNAGE
46	EXISTING EXTERIOR SIGNAGE
47	EXISTING EXTERIOR SIGNAGE
48	EXISTING EXTERIOR SIGNAGE
49	EXISTING EXTERIOR SIGNAGE
50	EXISTING EXTERIOR SIGNAGE
51	EXISTING EXTERIOR SIGNAGE
52	EXISTING EXTERIOR SIGNAGE
53	EXISTING EXTERIOR SIGNAGE
54	EXISTING EXTERIOR SIGNAGE
55	EXISTING EXTERIOR SIGNAGE
56	EXISTING EXTERIOR SIGNAGE
57	EXISTING EXTERIOR SIGNAGE
58	EXISTING EXTERIOR SIGNAGE
59	EXISTING EXTERIOR SIGNAGE
60	EXISTING EXTERIOR SIGNAGE
61	EXISTING EXTERIOR SIGNAGE
62	EXISTING EXTERIOR SIGNAGE
63	EXISTING EXTERIOR SIGNAGE
64	EXISTING EXTERIOR SIGNAGE
65	EXISTING EXTERIOR SIGNAGE
66	EXISTING EXTERIOR SIGNAGE
67	EXISTING EXTERIOR SIGNAGE
68	EXISTING EXTERIOR SIGNAGE
69	EXISTING EXTERIOR SIGNAGE
70	EXISTING EXTERIOR SIGNAGE
71	EXISTING EXTERIOR SIGNAGE
72	EXISTING EXTERIOR SIGNAGE
73	EXISTING EXTERIOR SIGNAGE
74	EXISTING EXTERIOR SIGNAGE
75	EXISTING EXTERIOR SIGNAGE
76	EXISTING EXTERIOR SIGNAGE
77	EXISTING EXTERIOR SIGNAGE
78	EXISTING EXTERIOR SIGNAGE
79	EXISTING EXTERIOR SIGNAGE
80	EXISTING EXTERIOR SIGNAGE
81	EXISTING EXTERIOR SIGNAGE
82	EXISTING EXTERIOR SIGNAGE
83	EXISTING EXTERIOR SIGNAGE
84	EXISTING EXTERIOR SIGNAGE
85	EXISTING EXTERIOR SIGNAGE
86	EXISTING EXTERIOR SIGNAGE
87	EXISTING EXTERIOR SIGNAGE
88	EXISTING EXTERIOR SIGNAGE
89	EXISTING EXTERIOR SIGNAGE
90	EXISTING EXTERIOR SIGNAGE
91	EXISTING EXTERIOR SIGNAGE
92	EXISTING EXTERIOR SIGNAGE
93	EXISTING EXTERIOR SIGNAGE
94	EXISTING EXTERIOR SIGNAGE
95	EXISTING EXTERIOR SIGNAGE
96	EXISTING EXTERIOR SIGNAGE
97	EXISTING EXTERIOR SIGNAGE
98	EXISTING EXTERIOR SIGNAGE
99	EXISTING EXTERIOR SIGNAGE
100	EXISTING EXTERIOR SIGNAGE

FOR EXISTING BUILDING OCCUPANCY AND HUMANITY PLEASE CALCULATE THE FLOOR AREA TO OBTAIN AND ADD 10% TO OBTAIN THE TOTAL FLOOR AREA.

REFERENCES

NO.	DESCRIPTION	DATE
1	PLACEMENT SUBMITTAL	08/20/24
2	PLACEMENT SUBMITTAL	08/20/24

LEGEND

	ACCESSIBLE ROUTE
	NOT IN CONTRACT
	LIMIT OF WORK

- GENERAL NOTES**
1. SITEWORK IMPROVEMENTS REQUIRES OUTDOOR LIBRARY NOT IN THE SCOPE OF WORK.
  2. THE CLIENT IS RESPONSIBLE FOR OBTAINING ALL NECESSARY PERMITS AND APPROVALS FOR OTHER SITE IMPROVEMENTS AND LANDSCAPE CHANGES FOR THE PROJECT.
  3. CONTRACTOR'S RESPONSIBILITY IS TO VERIFY THE LOT BOUNDARY AND EXISTING LOCAL LOCATION OF THE NEW STRUCTURE REFER TO CENL AND LANDSCAPE ARCHITECT'S RECORD DRAWINGS.
  4. REFER TO CENL AND LANDSCAPE ARCHITECT'S RECORD DRAWINGS FOR ALL UTILITY INFORMATION PERTAINING TO THE PROJECT.
  5. VERIFY GENERAL UTILITIES IN THE NEARBY FOR PROPOSED ALLOCATION OF WATER, POWER, AND ELECTRICITY BEFORE CONSTRUCTION.
  6. THE CLIENT SHALL VERIFY ANY PROPOSED RECONSTRUCTION, REFER TO CENL AND LANDSCAPE ARCHITECT'S RECORD DRAWINGS.

**CLIENT LOGO AND ADDRESS AREA**  
 411 E. CHURCH AVE.  
 PLACENTIA, CA 92679

**placentia**  
 LIBRARY DISTRICT

**PROJECT NAME**  
 OUTDOOR LIBRARY

**DESIGNER/ARCHITECT**  
 IDS GROUP  
 1 FETTERS CANYON ROAD, SUITE 100  
 IRVINE, CA 92618  
 TEL: 949-267-4500, FAX: 949-267-4500

**411 E. CHURCH AVE.**  
 PLACENTIA, CA 92679



**PROJECT IDENTIFICATION**

NO.	DESCRIPTION	DATE
1	PLACEMENT SUBMITTAL	08/20/24
2	PLACEMENT SUBMITTAL	08/20/24

**PROJECT IDENTIFICATION**

PROJECT NO. 23X117.00

DESIGNED BY: [Name]

CHECKED BY: [Name]

APPROVED BY: [Name]

**OVERALL SITE PLAN AND ACCESSIBLE ROUTE**

SHEET NUMBER: A-001

SHEET NO. 31 OF 53

**OVERALL SITE PLAN AND ACCESSIBLE ROUTE**

SHEET NUMBER: A-001

SHEET NO. 31 OF 53

**OVERALL SITE PLAN AND ACCESSIBLE ROUTE**

SHEET NUMBER: A-001

SHEET NO. 31 OF 53

**OVERALL SITE PLAN AND ACCESSIBLE ROUTE**

SHEET NUMBER: A-001

SHEET NO. 31 OF 53

**OVERALL SITE PLAN AND ACCESSIBLE ROUTE**

SHEET NUMBER: A-001

SHEET NO. 31 OF 53

**OVERALL SITE PLAN AND ACCESSIBLE ROUTE**

SHEET NUMBER: A-001

SHEET NO. 31 OF 53

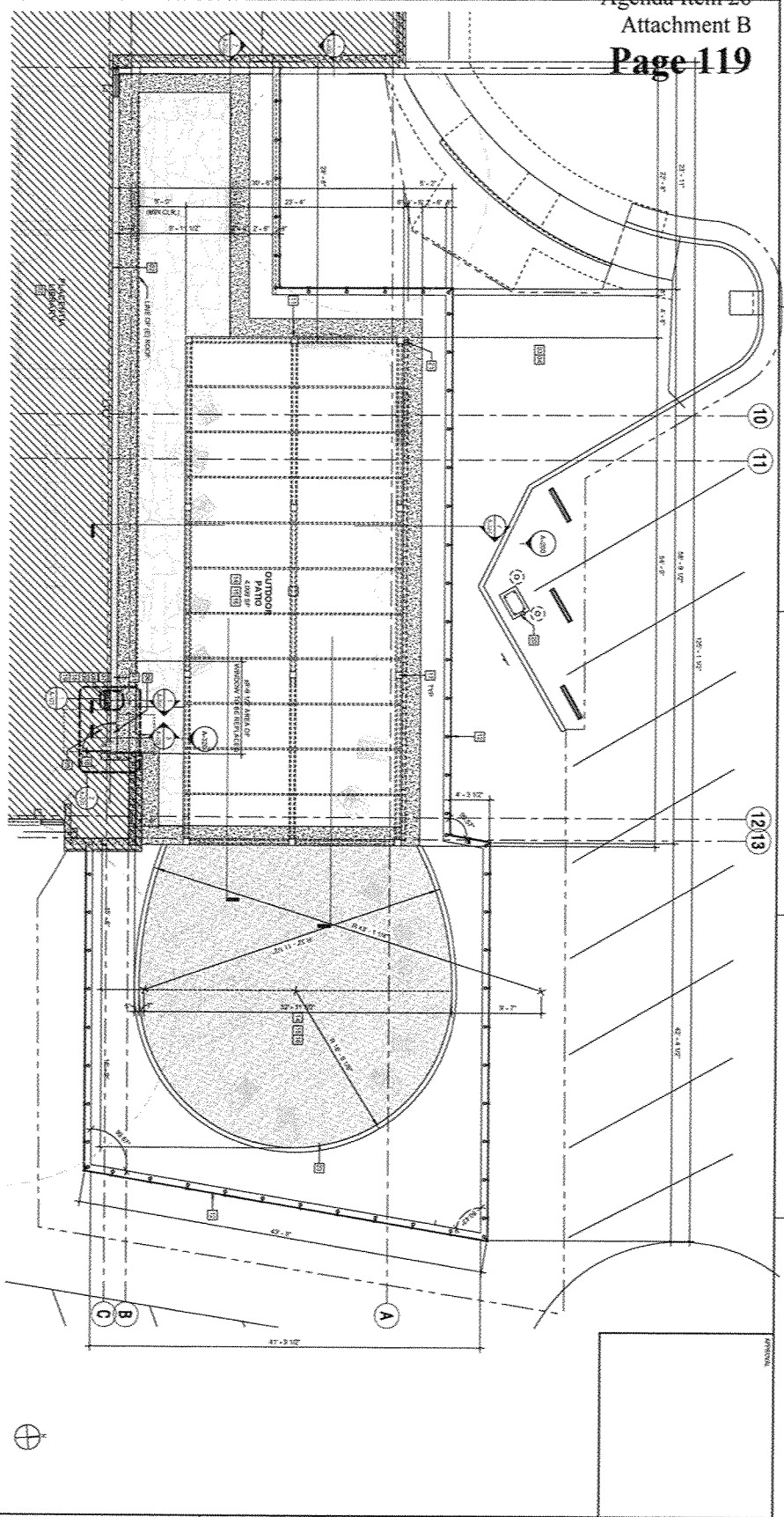

**GENERAL NOTES**

1. SEE GENERAL NOTES FOR ARCHITECTURAL NOTES AND SPECIFICATIONS.
2. MATCH AND REVEAL ALL EXISTING PARTITIONS AFTER DEMOLITION WITH FINISHING AND REPAIR WORK. MATCH AND REVEAL ALL EXISTING PARTITIONS WITH FINISHING AND REPAIR WORK. MATCH AND REVEAL ALL EXISTING PARTITIONS WITH FINISHING AND REPAIR WORK.
3. COORDINATE THE WORK SHOWN ON THE DRAWINGS WITH THE PROJECT MANUAL IN ORDER TO COMPLETE THE PROJECT AS INTENDED.
4. ALL CONSTRUCTION SHALL BE IN ACCORDANCE WITH THE LATEST CODES AS ADOPTED BY THE REGIONAL AGENCY.
5. ALL WORK SHALL BE SUBJECT TO CONTRACT MODIFICATIONS AND CHANGES. THE CONTRACTOR SHALL BE RESPONSIBLE FOR OBTAINING ALL NECESSARY PERMITS AND APPROVALS FROM THE REGIONAL AGENCY.
6. THE CONTRACTOR SHALL PROVIDE AND MAINTAIN THE EXISTING UTILITIES AND SHALL BE RESPONSIBLE FOR OBTAINING ALL NECESSARY PERMITS AND APPROVALS FROM THE REGIONAL AGENCY.
7. THE CONTRACTOR SHALL REMOVE AND OCCUPATIONAL ALL EXISTING UTILITIES AND REPAIR OR REPLACE AS NECESSARY. THE CONTRACTOR SHALL BE RESPONSIBLE FOR OBTAINING ALL NECESSARY PERMITS AND APPROVALS FROM THE REGIONAL AGENCY.
8. ALL EXISTING UTILITIES SHALL BE PROTECTED AND SHALL NOT BE REMOVED UNLESS NECESSARY. THE CONTRACTOR SHALL BE RESPONSIBLE FOR OBTAINING ALL NECESSARY PERMITS AND APPROVALS FROM THE REGIONAL AGENCY.
9. ALL EXISTING UTILITIES SHALL BE PROTECTED AND SHALL NOT BE REMOVED UNLESS NECESSARY. THE CONTRACTOR SHALL BE RESPONSIBLE FOR OBTAINING ALL NECESSARY PERMITS AND APPROVALS FROM THE REGIONAL AGENCY.
10. COORDINATE THE WORK SHOWN ON THE DRAWINGS WITH THE PROJECT MANUAL IN ORDER TO COMPLETE THE PROJECT AS INTENDED.
11. COORDINATE THE WORK SHOWN ON THE DRAWINGS WITH THE PROJECT MANUAL IN ORDER TO COMPLETE THE PROJECT AS INTENDED.
12. COORDINATE THE WORK SHOWN ON THE DRAWINGS WITH THE PROJECT MANUAL IN ORDER TO COMPLETE THE PROJECT AS INTENDED.

**LEGEND**

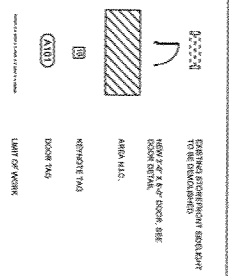

**KEYNOTES**

NO.	DESCRIPTION
01	ENLARGED OUTDOOR PLAN
02	EXISTING CONDITIONS
03	NEW WORK
04	DOOR DETAIL
05	EXISTING UTILITIES
06	NEW UTILITIES
07	EXISTING PARTITIONS
08	NEW PARTITIONS
09	EXISTING FLOORS
10	NEW FLOORS
11	EXISTING ROOFS
12	NEW ROOFS
13	EXISTING WALLS
14	NEW WALLS
15	EXISTING CEILING
16	NEW CEILING
17	EXISTING MECHANICAL
18	NEW MECHANICAL
19	EXISTING ELECTRICAL
20	NEW ELECTRICAL
21	EXISTING PIPING
22	NEW PIPING
23	EXISTING LANDSCAPE
24	NEW LANDSCAPE
25	EXISTING SITEWORK
26	NEW SITEWORK

01 ENLARGED OUTDOOR PLAN | 3/16" = 1'-0" | 1

 <p><b>IDS GROUP</b> 11675 CANON ROAD, SUITE 150 IRVINE, CA 92618 TEL: 949.267.4900 FAX: 949.267.4905</p>	<p><b>placentia</b> LIBRARY DISTRICT</p>	<p>CLIENT LOGO AND ADDRESS AREA 411 E. CHAPMAN AVE. PLACENTIA, CA 92670</p>	<p><b>OUTDOOR LIBRARY</b></p>	<p><b>PROJECT INFO</b> 411 E. CHAPMAN AVE. PLACENTIA, CA 92670 PROJECT NAME: <b>OUTDOOR LIBRARY</b></p>
<p><b>PROJECT IDENTIFICATION</b> PROJECT NO.: 23X117.00 SHEET NO.: 32 OF 33</p>	<p><b>DESIGNER</b> A-101</p>	<p><b>DRAWN BY</b> MF</p>	<p><b>CHECKED BY</b> MS</p>	<p><b>APPROVED BY</b> MS</p>

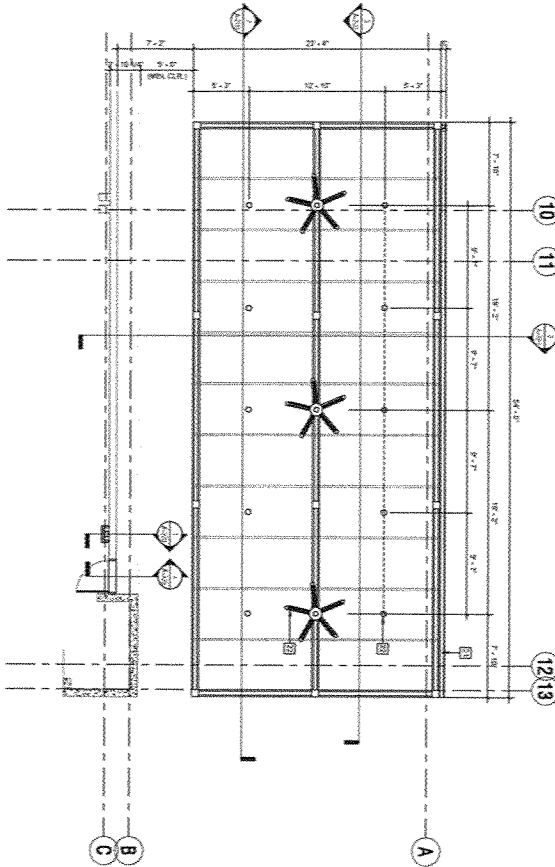

REFLECTED CEILING PLAN Site # 142 1

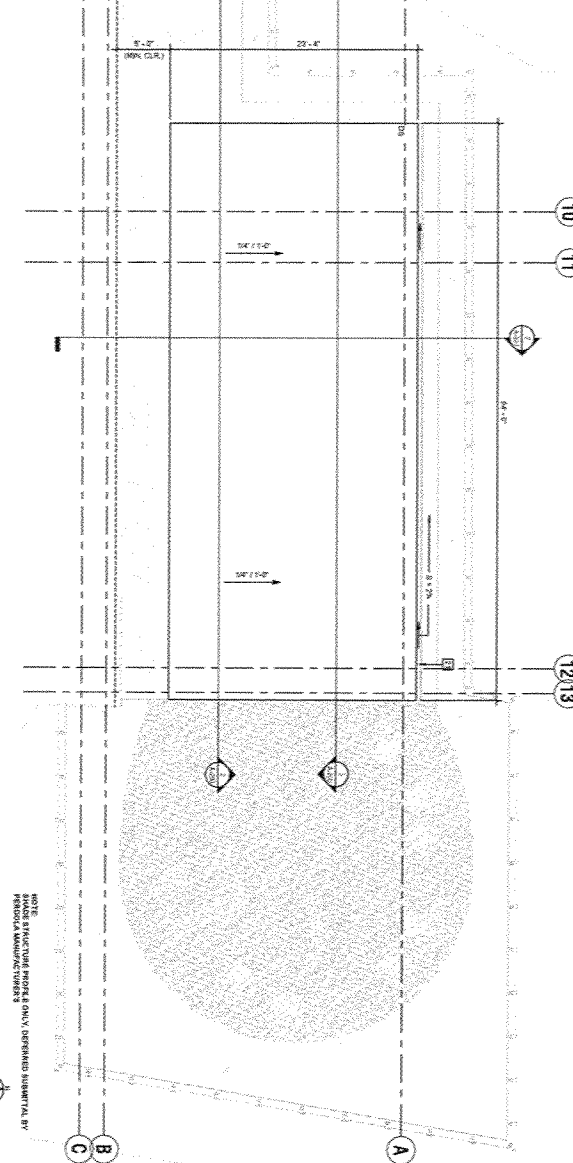

ROOF PLAN Site # 142 2

DATE	DESCRIPTION
20	REVISED RCP AND RP FOR SUBMITTAL
21	REVISED RCP AND RP FOR SUBMITTAL



**IDS GROUP**  
1 FETTER CANYON ROAD, SUITE 130  
PLACENTIA, CA 92666  
TEL: 949-581-4800 FAX: 949-581-4809

**OUTDOOR LIBRARY**  
411 E. CHAPMAN AVE.  
PLACENTIA, CA 92669



**A-102**  
SHEET NO. 33 OF 53

**REFLECTED CEILING AND ROOF PLAN**

PROJECT NUMBER: A-102  
SHEET NO. 33 OF 53

REV#	DESCRIPTION	DATE
A	PLAN CHECK SUBMITTAL	8/26/24

**PROJECT IDENTIFICATION**  
PROJECT NAME: PLACENTIA LIBRARY DISTRICT OUTDOOR LIBRARY  
PROJECT NO.: 23X117.00  
OWNER: PLACENTIA LIBRARY DISTRICT  
ARCHITECT: IDS GROUP  
DATE: 8/20/2024

**DESIGNER INFORMATION**  
DESIGNER: ROBERT J. FRANCIS  
LICENSE NO.: 73739  
STATE OF CALIFORNIA

**CLIENT INFORMATION**  
CLIENT: PLACENTIA LIBRARY DISTRICT  
ADDRESS: 411 E. CHAPMAN AVE., PLACENTIA, CA 92669

**PROJECT INFORMATION**  
PROJECT NAME: OUTDOOR LIBRARY  
PROJECT NO.: 23X117.00

**DATE**  
DATE: 8/20/2024

**APPROVED BY**  
APPROVED BY: [Signature]  
APPROVED BY: [Signature]

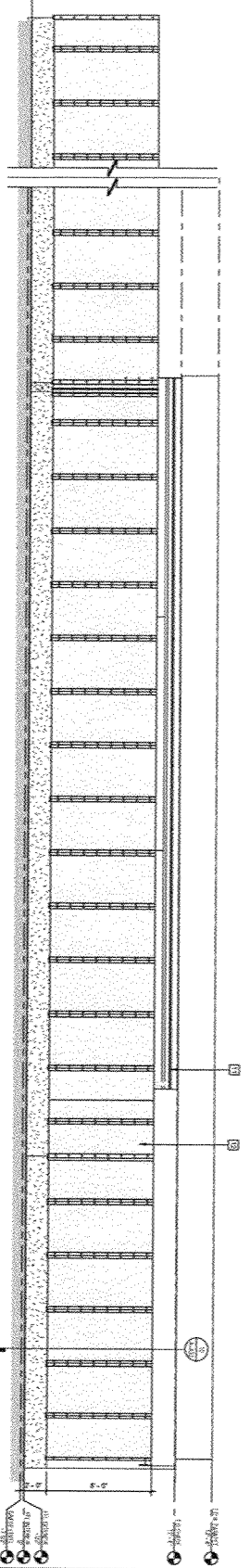
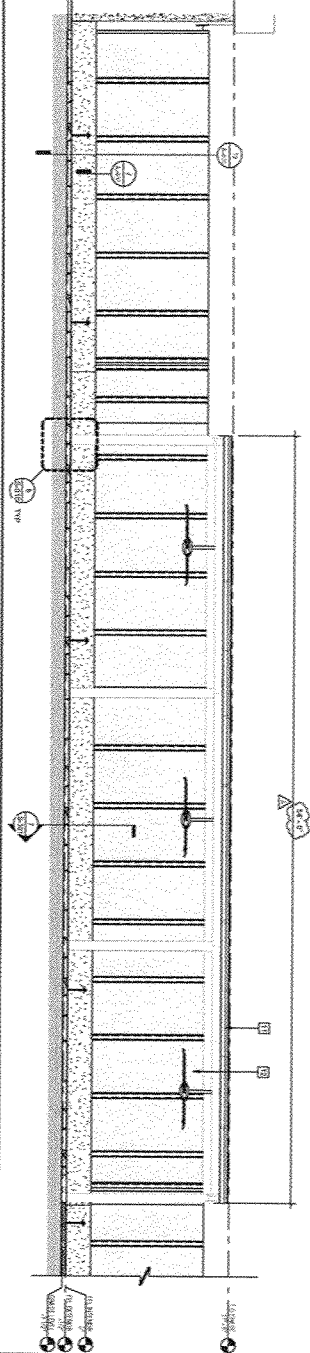
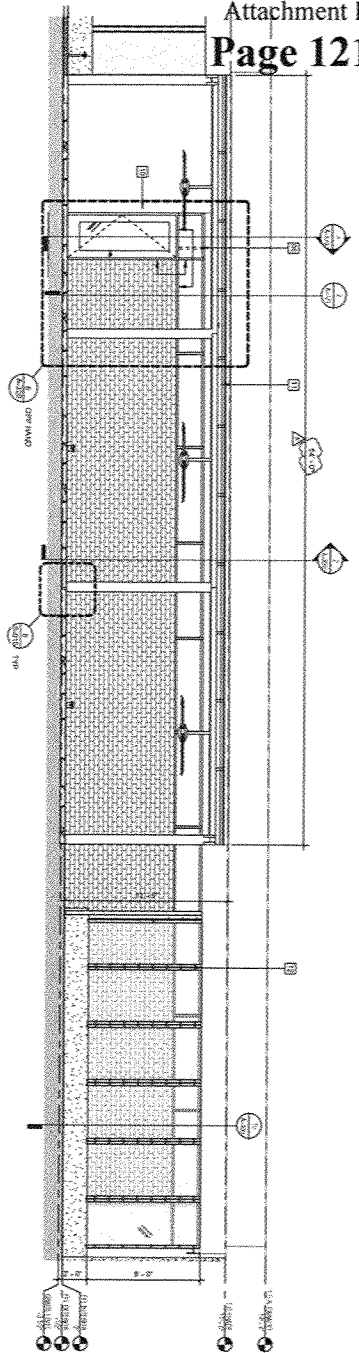

REVISIONS

NO.	DATE	DESCRIPTION
01		ISSUE FOR PERMITTING
02		REVISED PER PERMITTING
03		REVISED PER PERMITTING
04		REVISED PER PERMITTING
05		REVISED PER PERMITTING
06		REVISED PER PERMITTING
07		REVISED PER PERMITTING
08		REVISED PER PERMITTING
09		REVISED PER PERMITTING
10		REVISED PER PERMITTING
11		REVISED PER PERMITTING
12		REVISED PER PERMITTING

CLIENT LOGO AND ADDRESS AREA  
411 E. CHURCH AVE  
PLACENTIA, CA 92660

**OUTDOOR LIBRARY**

IDS GROUP  
1 PEPPER CANYON ROAD, SUITE 100  
IRVINE, CA 92614  
TEL: 949-261-8500 FAX: 949-261-8500

REV#	DESCRIPTION	DATE
A	PERMIT CHECK SUBMITTAL	08/20/24
B	PERMIT CHECK SUBMITTAL	08/20/24

**PROJECT IDENTIFICATION**

THIS DRAWING AND ALL OTHER DRAWINGS ARE THE PROPERTY OF IDS GROUP AND SHALL NOT BE REPRODUCED OR TRANSMITTED IN ANY FORM OR BY ANY MEANS, ELECTRONIC OR MECHANICAL, WITHOUT THE WRITTEN PERMISSION OF IDS GROUP.

IDS PROJECT NO. 23X117.00

DRAWN BY: Author

CHECKED BY: Author

APPROVED BY: Approver

**ELEVATIONS AND SECTIONS**

**A-200**

SHEET NO. 34 OF 53

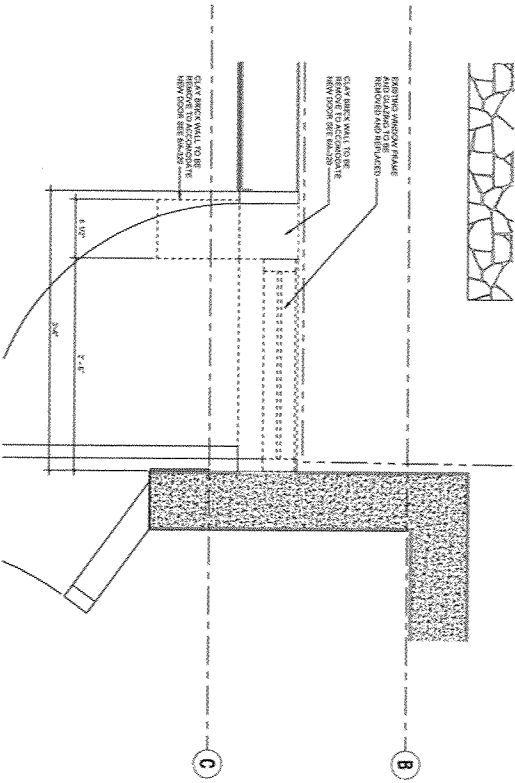

DEMOLITION PLAN 1/2" = 1'-0" 1

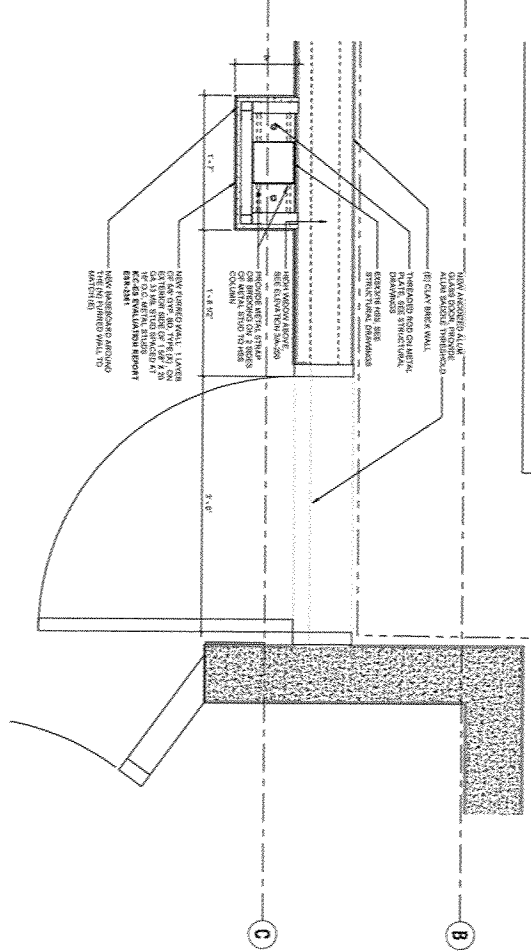

ENLARGED OUTDOOR ENTRY PLAN 1/2" = 1'-0" 2

DATE



CLIENT LOGO AND ADDRESS AREA  
411 E. CANONVALE AVENUE, PLACENTIA, CA 92676

PROJECT NAME  
**OUTDOOR LIBRARY**

411 E. CANONVALE AVENUE  
PLACENTIA, CA 92676



1 PETERS CANYON ROAD, SUITE 100  
IRVINE, CA 92618  
TEL: 949-261-4800 FAX: 949-261-7000



REV	DESCRIPTION	DATE
1	FINAL CHECK SUBMITTAL	8/20/24
2	FINAL CHECK SUBMITTAL	8/20/24

**PROJECT IDENTIFICATION**  
DATE SUBMITTED: 8/20/24  
DATE APPROVED: 8/20/24  
PROJECT NO: 23A117.00

**DESIGNER**  
DRAWN BY: Alpha  
CHECKED BY: Checker  
APPROVED BY: Approver

**SHEET TITLE**  
ENLARGED OUTDOOR ENTRY PLAN

**SHEET NUMBER**  
A-201

**SHEET NO.** 35 **OF** 33



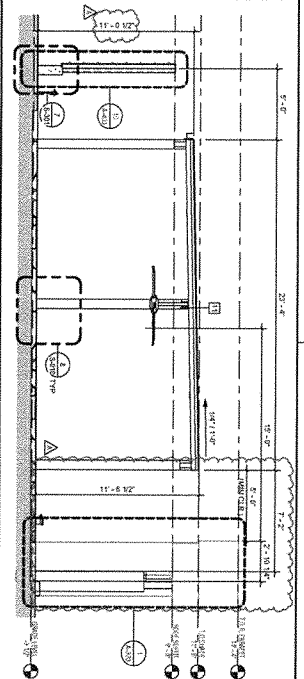
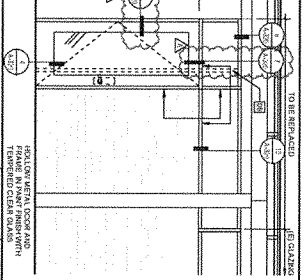
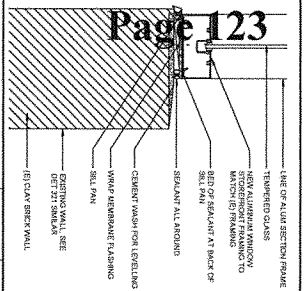

### DOOR & FRAME GENERAL NOTES

- 1. DOOR AND FRAME ASSEMBLY SHALL COMPLY WITH ALL GENERAL NOTES.
- 2. THE DOOR AND FRAME SHALL BE COMPATIBLE WITH THE FINISHES AND MATERIALS SPECIFIED FOR THE COOR.
- 3. THE DOOR AND FRAME SHALL BE FABRICATED BY THE MANUFACTURER OF THE DOOR AND FRAME.
- 4. THE DOOR AND FRAME SHALL BE FABRICATED BY THE MANUFACTURER OF THE DOOR AND FRAME.
- 5. THE DOOR AND FRAME SHALL BE FABRICATED BY THE MANUFACTURER OF THE DOOR AND FRAME.
- 6. THE DOOR AND FRAME SHALL BE FABRICATED BY THE MANUFACTURER OF THE DOOR AND FRAME.
- 7. THE DOOR AND FRAME SHALL BE FABRICATED BY THE MANUFACTURER OF THE DOOR AND FRAME.
- 8. THE DOOR AND FRAME SHALL BE FABRICATED BY THE MANUFACTURER OF THE DOOR AND FRAME.
- 9. THE DOOR AND FRAME SHALL BE FABRICATED BY THE MANUFACTURER OF THE DOOR AND FRAME.
- 10. THE DOOR AND FRAME SHALL BE FABRICATED BY THE MANUFACTURER OF THE DOOR AND FRAME.

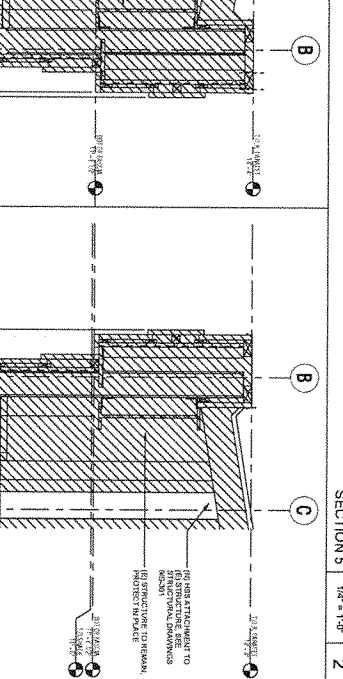
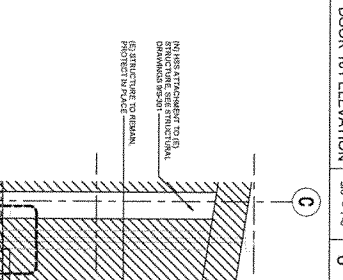
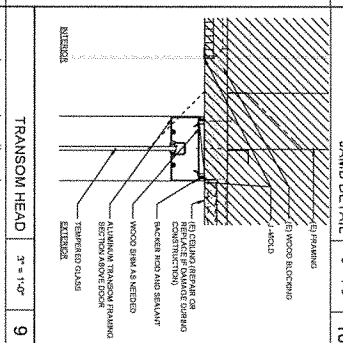

### DOOR & FRAME MATERIALS

- 1. INSULATION: MINIMUM DOOR ASSEMBLY R-VALUE IS REQUIRED.
- 2. DOOR AND FRAME FINISHES: PAINTED FINISH.
- 3. GLASS TYPES: 1/2\"/>

### DOOR HARDWARE

QTY	DESCRIPTION	CATALOG NO.	FINISH	MARK
1	DOOR HANDLE	12345678	BRASS	ABC
1	DOOR LOCK	12345678	BRASS	ABC
1	DOOR LATCH	12345678	BRASS	ABC
1	DOOR STOP	12345678	BRASS	ABC
1	DOOR STRIKE	12345678	BRASS	ABC
1	DOOR HINGE	12345678	BRASS	ABC
1	DOOR ROLLER	12345678	BRASS	ABC
1	DOOR SEAL	12345678	BRASS	ABC
1	DOOR SWEEP	12345678	BRASS	ABC
1	DOOR GUIDE	12345678	BRASS	ABC
1	DOOR STOP	12345678	BRASS	ABC
1	DOOR STRIKE	12345678	BRASS	ABC
1	DOOR HINGE	12345678	BRASS	ABC
1	DOOR ROLLER	12345678	BRASS	ABC
1	DOOR SEAL	12345678	BRASS	ABC
1	DOOR SWEEP	12345678	BRASS	ABC
1	DOOR GUIDE	12345678	BRASS	ABC

### KEYNOTES

- 1. REVISIONS TO THIS SET SHALL BE INDICATED BY A CIRCLED NUMBER AND DATE.
- 2. THE DOOR AND FRAME SHALL BE COMPATIBLE WITH THE FINISHES AND MATERIALS SPECIFIED FOR THE COOR.
- 3. THE DOOR AND FRAME SHALL BE FABRICATED BY THE MANUFACTURER OF THE DOOR AND FRAME.
- 4. THE DOOR AND FRAME SHALL BE FABRICATED BY THE MANUFACTURER OF THE DOOR AND FRAME.
- 5. THE DOOR AND FRAME SHALL BE FABRICATED BY THE MANUFACTURER OF THE DOOR AND FRAME.
- 6. THE DOOR AND FRAME SHALL BE FABRICATED BY THE MANUFACTURER OF THE DOOR AND FRAME.
- 7. THE DOOR AND FRAME SHALL BE FABRICATED BY THE MANUFACTURER OF THE DOOR AND FRAME.
- 8. THE DOOR AND FRAME SHALL BE FABRICATED BY THE MANUFACTURER OF THE DOOR AND FRAME.
- 9. THE DOOR AND FRAME SHALL BE FABRICATED BY THE MANUFACTURER OF THE DOOR AND FRAME.
- 10. THE DOOR AND FRAME SHALL BE FABRICATED BY THE MANUFACTURER OF THE DOOR AND FRAME.

CLIENT (OOO) AND ADDRESS AREA  
411 E. CHAPMAN AVE  
PLACENTIA, CA 92679

PROJECT NAME  
OUTDOOR LIBRARY

IDS GROUP  
1 PETERS CANYON ROAD, SUITE 130  
PLACENTIA, CA 92679  
TEL: 949-987-0800, FAX: 949-987-0800

REV	DESCRIPTION	DATE
1	PLANT CHECK SUBMITTAL	08/20/24
2	PLANT CHECK SUBMITTAL	08/20/24

PROJECT IDENTIFICATION  
NO. 23X117.00  
THE GENERAL SET OF THIS SHEET IS A 3X  
THIS SHEET IS A PART OF THE PROJECT AND  
SHALL NOT BE REPRODUCED OR COPIED  
WITHOUT THE WRITTEN PERMISSION OF IDS GROUP

IDS PROJECT NO. 23X117.00

DRAWN BY MF  
CHECKED BY SS  
APPROVED BY JS

SHEET NUMBER  
A-320

SHEET NO. 38 OF 53

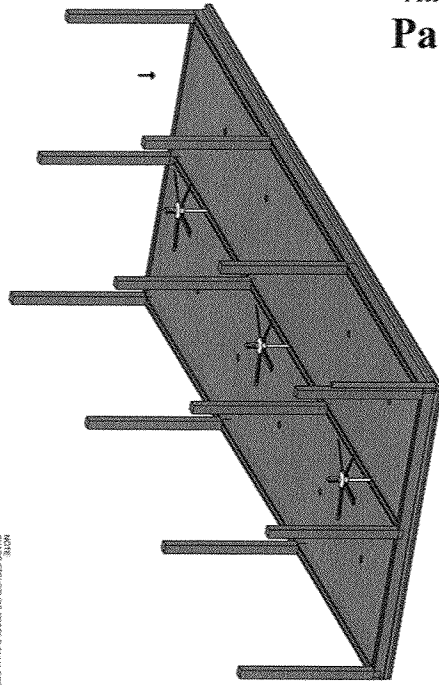

AXONOMETRIC-SHADE STRUCTURE

NOTE: SHADE STRUCTURE FINISHES OAK & DISTRESSED SUBMITTAL BY THORCOCK MANUFACTURING

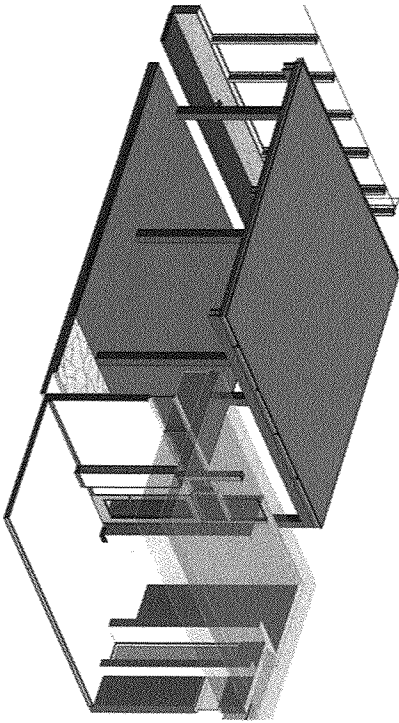

AXONOMETRIC-DOOR OPENING TO OUTDOOR LIBRARY

3

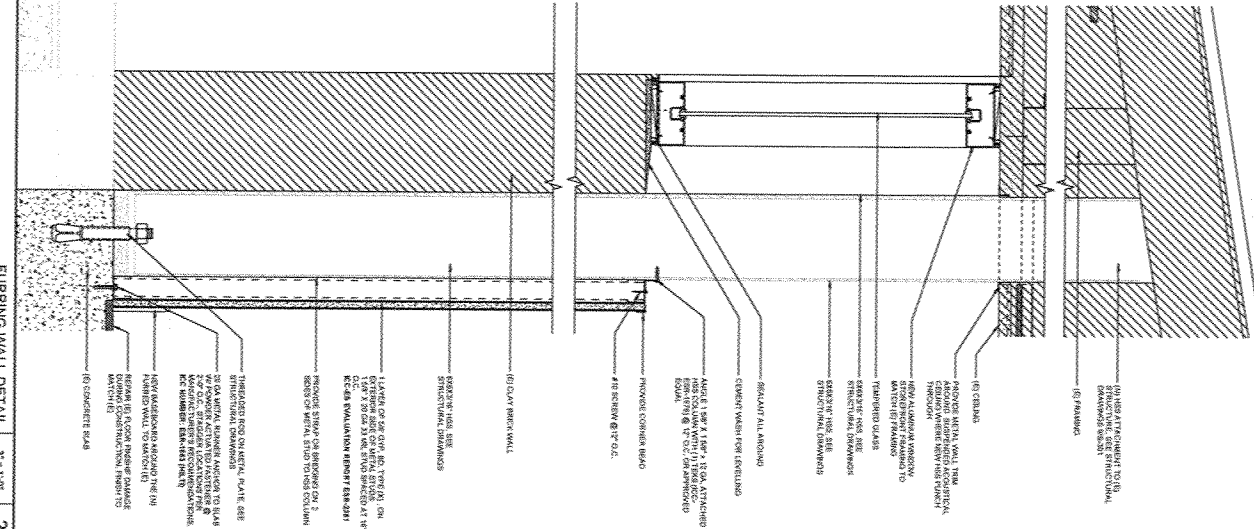

FURRING WALL DETAIL 3" x 13"

2

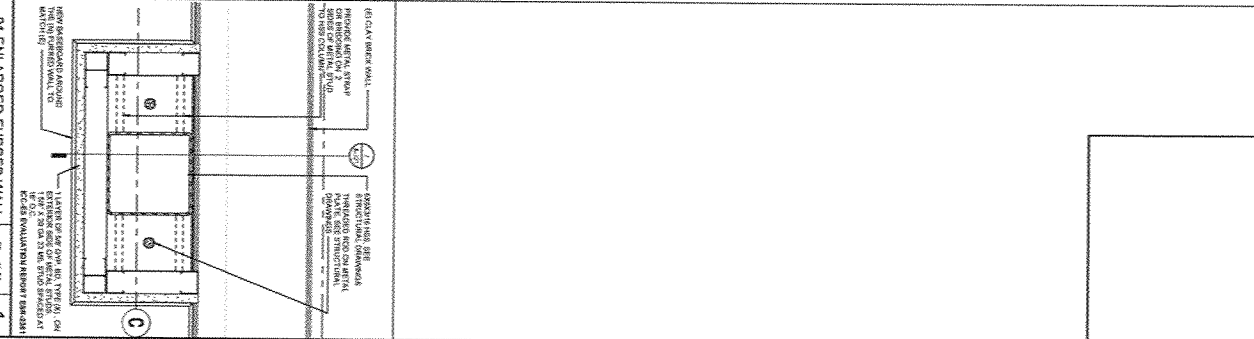

01 ENLARGED FURRED WALL 3" x 13"

1

SHEET



CLIENT LOGO AND ADDRESS AREA  
411 E. CHERRY AVE  
PLACENTIA, CA 92669

PROJECT NAME  
**OUTDOOR LIBRARY**

PROJECT NUMBER  
411 E. CHERRY AVE  
PLACENTIA, CA 92669



1 PETERS CANYON ROAD, SUITE 130  
IRVINE, CA 92618  
TEL: 949.381.8500 FAX: 949.381.0800



REV#	DESCRIPTION	DATE
A	FINAL CHECK SUBMITTAL	08/20/24
B	PERIODIC CHECK SUBMITTAL	08/20/24

**PROJECT IDENTIFICATION**  
PROJECT NAME: 411 E. CHERRY AVE  
PROJECT NUMBER: 411 E. CHERRY AVE  
PROJECT ADDRESS: 411 E. CHERRY AVE  
PROJECT CITY: PLACENTIA, CA 92669  
PROJECT STATE: CA  
PROJECT ZIP: 92669  
PROJECT COUNTY: SAN JUAN BAPTISTA  
PROJECT DISTRICT: PLACENTIA  
PROJECT PHASE: CONSTRUCTION  
PROJECT START DATE: 08/20/24  
PROJECT END DATE: 08/20/24  
PROJECT STATUS: SUBMITTAL

**DESIGN INFORMATION**  
DESIGNED BY: [Signature]  
CHECKED BY: [Signature]  
APPROVED BY: [Signature]

SHEET NUMBER  
**A-321**

SHEET NO. 37 OF 53



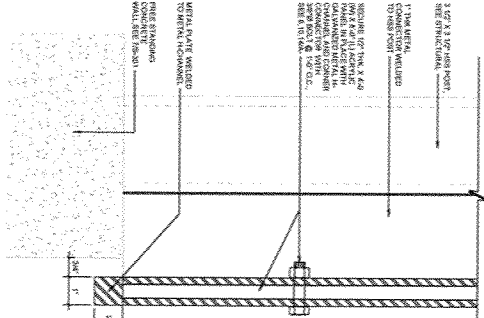
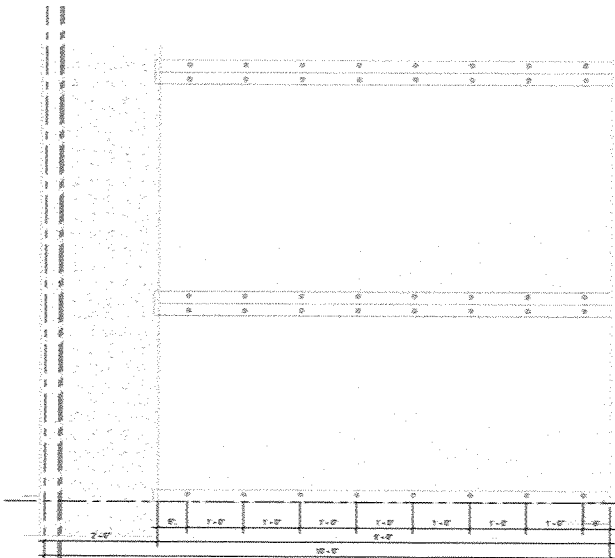
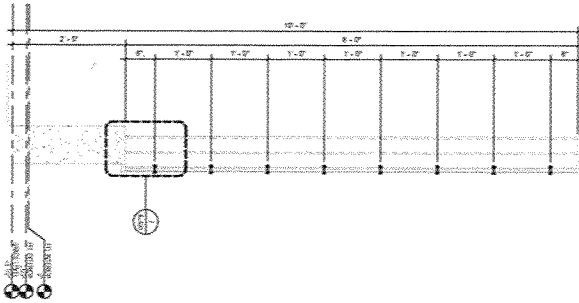
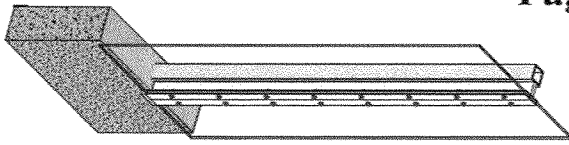

AXONOMETRIC-ACRYLIC FENCE

14

FENCE SECTION

1" = 1'-0"

10

FENCE PARTIAL ELEVATION

1" = 1'-0"

6

FENCE BOTTOM CONNECTION

6" = 1'-0"

2

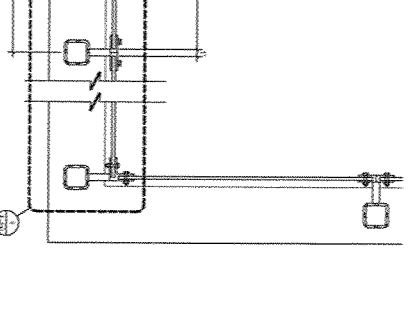
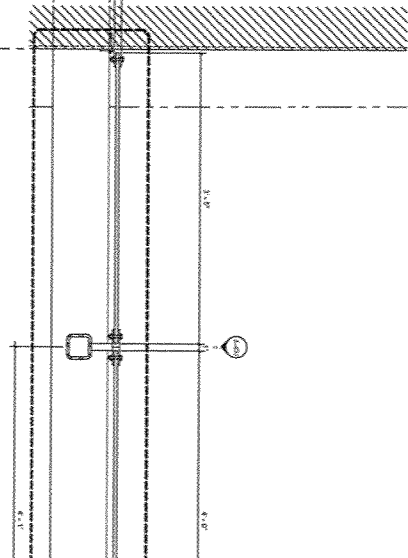
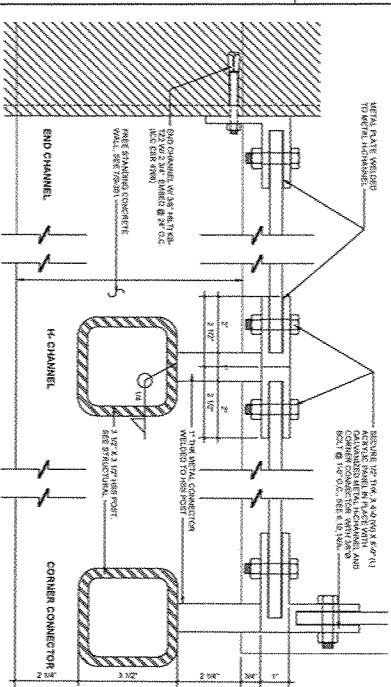

COLUMN ATTACHMENT AND PANEL CONNECTORS DETAILS

6" = 1'-0"

9

9

FENCE - PARTIAL PLAN

1 1/2" = 1'-0"

1



CLERK: LOU ANN SANDERS-ARLA  
411 E. CHAPMAN AVE.  
PLACENTIA, CA 92670

PROJECT NAME  
OUTDOOR LIBRARY

411 E. CHAPMAN AVE.  
PLACENTIA, CA 92670



1 PETERS CANYON ROAD, SUITE 100  
IRVINE, CA 92618  
TEL: 949-267-4000 FAX: 949-267-0900



REV.	DESCRIPTION	DATE
1	ISSUED FOR PERMIT	8/20/24
2	ISSUED FOR PERMIT	8/20/24
3	ISSUED FOR PERMIT	8/20/24
4	ISSUED FOR PERMIT	8/20/24
5	ISSUED FOR PERMIT	8/20/24
6	ISSUED FOR PERMIT	8/20/24
7	ISSUED FOR PERMIT	8/20/24
8	ISSUED FOR PERMIT	8/20/24
9	ISSUED FOR PERMIT	8/20/24
10	ISSUED FOR PERMIT	8/20/24

PROJECT IDENTIFICATION  
 PROJECT NO. 23X117.00  
 DRAWN BY: A. Francis  
 CHECKED BY: A. Francis  
 APPROVED BY: A. Francis

SHEET NO. 38 OF 50  
**A-400**

FENCE DETAILS



MASONRY

ALL MASONRY SHALL BE CONSTRUCTED ACCORDING TO THE LATEST EDITIONS OF THE FOLLOWING CODES AND STANDARDS UNLESS OTHERWISE SPECIFIED:

- 2. 2019 INTERNATIONAL BUILDING CODE (IBC)
- 3. 2021 INTERNATIONAL ENERGY EFFICIENCY CODE (IECC)
- 4. 2019 INTERNATIONAL MECHANICAL AND PLUMBING CODE (IMC)
- 5. 2019 INTERNATIONAL PLUMBING CODE (IPC)
- 6. 2015 INTERNATIONAL CONCRETE AND ALUMINUM DESIGN CODES (ACI 308R-15)
- 7. 2015 INTERNATIONAL CODES AND STANDARDS FOR STRUCTURAL ALUMINUM DESIGN (AISC 308-15)

ACI	ASTM	ASTM	ASTM	ASTM	ASTM	ASTM	ASTM	ASTM	ASTM	ASTM	ASTM
1	4	305	308	309	311	315	322	323	324	325	327
CONCRETE	STEEL	STEEL	STEEL	STEEL	STEEL	STEEL	STEEL	STEEL	STEEL	STEEL	STEEL
...	...	...	...	...	...	...	...	...	...	...	...

**3. ADORNMENTS SHALL CONFORM TO ASTM C1107 FOR FINISHES AND ASTM C1108 FOR SETTING.**

NO.	DESCRIPTION	CONCRETE SPECIAL INSPECTION	STRUCTURAL SPECIAL INSPECTION	REFERENCE	TEST
1.	INSPECT AND TEST REINFORCING BARS INCLUDING VERIFICATION OF CORRECTION OF REBAR POSITION AND COVERAGE WITH S.W. COMPLY WITH SECTION 05120 OF THE SPECIFICATIONS.	X		ACI 308.1, 308.2, 308.3, 308.4, 308.5, 308.6, 308.7, 308.8, 308.9, 308.10, 308.11, 308.12, 308.13, 308.14, 308.15, 308.16, 308.17, 308.18, 308.19, 308.20, 308.21, 308.22, 308.23, 308.24, 308.25, 308.26, 308.27, 308.28, 308.29, 308.30, 308.31, 308.32, 308.33, 308.34, 308.35, 308.36, 308.37, 308.38, 308.39, 308.40, 308.41, 308.42, 308.43, 308.44, 308.45, 308.46, 308.47, 308.48, 308.49, 308.50, 308.51, 308.52, 308.53, 308.54, 308.55, 308.56, 308.57, 308.58, 308.59, 308.60, 308.61, 308.62, 308.63, 308.64, 308.65, 308.66, 308.67, 308.68, 308.69, 308.70, 308.71, 308.72, 308.73, 308.74, 308.75, 308.76, 308.77, 308.78, 308.79, 308.80, 308.81, 308.82, 308.83, 308.84, 308.85, 308.86, 308.87, 308.88, 308.89, 308.90, 308.91, 308.92, 308.93, 308.94, 308.95, 308.96, 308.97, 308.98, 308.99, 309.00, 309.01, 309.02, 309.03, 309.04, 309.05, 309.06, 309.07, 309.08, 309.09, 309.10, 309.11, 309.12, 309.13, 309.14, 309.15, 309.16, 309.17, 309.18, 309.19, 309.20, 309.21, 309.22, 309.23, 309.24, 309.25, 309.26, 309.27, 309.28, 309.29, 309.30, 309.31, 309.32, 309.33, 309.34, 309.35, 309.36, 309.37, 309.38, 309.39, 309.40, 309.41, 309.42, 309.43, 309.44, 309.45, 309.46, 309.47, 309.48, 309.49, 309.50, 309.51, 309.52, 309.53, 309.54, 309.55, 309.56, 309.57, 309.58, 309.59, 309.60, 309.61, 309.62, 309.63, 309.64, 309.65, 309.66, 309.67, 309.68, 309.69, 309.70, 309.71, 309.72, 309.73, 309.74, 309.75, 309.76, 309.77, 309.78, 309.79, 309.80, 309.81, 309.82, 309.83, 309.84, 309.85, 309.86, 309.87, 309.88, 309.89, 309.90, 309.91, 309.92, 309.93, 309.94, 309.95, 309.96, 309.97, 309.98, 309.99, 310.00	CONCRETE, REBAR, TIE BARS
2.	INSPECT AND TEST REINFORCING BARS INCLUDING VERIFICATION OF CORRECTION OF REBAR POSITION AND COVERAGE WITH S.W. COMPLY WITH SECTION 05120 OF THE SPECIFICATIONS.	X		ACI 308.1, 308.2, 308.3, 308.4, 308.5, 308.6, 308.7, 308.8, 308.9, 308.10, 308.11, 308.12, 308.13, 308.14, 308.15, 308.16, 308.17, 308.18, 308.19, 308.20, 308.21, 308.22, 308.23, 308.24, 308.25, 308.26, 308.27, 308.28, 308.29, 308.30, 308.31, 308.32, 308.33, 308.34, 308.35, 308.36, 308.37, 308.38, 308.39, 308.40, 308.41, 308.42, 308.43, 308.44, 308.45, 308.46, 308.47, 308.48, 308.49, 308.50, 308.51, 308.52, 308.53, 308.54, 308.55, 308.56, 308.57, 308.58, 308.59, 308.60, 308.61, 308.62, 308.63, 308.64, 308.65, 308.66, 308.67, 308.68, 308.69, 308.70, 308.71, 308.72, 308.73, 308.74, 308.75, 308.76, 308.77, 308.78, 308.79, 308.80, 308.81, 308.82, 308.83, 308.84, 308.85, 308.86, 308.87, 308.88, 308.89, 308.90, 308.91, 308.92, 308.93, 308.94, 308.95, 308.96, 308.97, 308.98, 308.99, 309.00, 309.01, 309.02, 309.03, 309.04, 309.05, 309.06, 309.07, 309.08, 309.09, 309.10, 309.11, 309.12, 309.13, 309.14, 309.15, 309.16, 309.17, 309.18, 309.19, 309.20, 309.21, 309.22, 309.23, 309.24, 309.25, 309.26, 309.27, 309.28, 309.29, 309.30, 309.31, 309.32, 309.33, 309.34, 309.35, 309.36, 309.37, 309.38, 309.39, 309.40, 309.41, 309.42, 309.43, 309.44, 309.45, 309.46, 309.47, 309.48, 309.49, 309.50, 309.51, 309.52, 309.53, 309.54, 309.55, 309.56, 309.57, 309.58, 309.59, 309.60, 309.61, 309.62, 309.63, 309.64, 309.65, 309.66, 309.67, 309.68, 309.69, 309.70, 309.71, 309.72, 309.73, 309.74, 309.75, 309.76, 309.77, 309.78, 309.79, 309.80, 309.81, 309.82, 309.83, 309.84, 309.85, 309.86, 309.87, 309.88, 309.89, 309.90, 309.91, 309.92, 309.93, 309.94, 309.95, 309.96, 309.97, 309.98, 309.99, 310.00	CONCRETE, REBAR, TIE BARS

NO.	DESCRIPTION	CONTRACTOR SPECIAL INSPECTION	STRUCTURAL SPECIAL INSPECTION	REFERENCE	TEST
1.	INSPECT AND TEST REINFORCING BARS INCLUDING VERIFICATION OF CORRECTION OF REBAR POSITION AND COVERAGE WITH S.W. COMPLY WITH SECTION 05120 OF THE SPECIFICATIONS.	X		ACI 308.1, 308.2, 308.3, 308.4, 308.5, 308.6, 308.7, 308.8, 308.9, 308.10, 308.11, 308.12, 308.13, 308.14, 308.15, 308.16, 308.17, 308.18, 308.19, 308.20, 308.21, 308.22, 308.23, 308.24, 308.25, 308.26, 308.27, 308.28, 308.29, 308.30, 308.31, 308.32, 308.33, 308.34, 308.35, 308.36, 308.37, 308.38, 308.39, 308.40, 308.41, 308.42, 308.43, 308.44, 308.45, 308.46, 308.47, 308.48, 308.49, 308.50, 308.51, 308.52, 308.53, 308.54, 308.55, 308.56, 308.57, 308.58, 308.59, 308.60, 308.61, 308.62, 308.63, 308.64, 308.65, 308.66, 308.67, 308.68, 308.69, 308.70, 308.71, 308.72, 308.73, 308.74, 308.75, 308.76, 308.77, 308.78, 308.79, 308.80, 308.81, 308.82, 308.83, 308.84, 308.85, 308.86, 308.87, 308.88, 308.89, 308.90, 308.91, 308.92, 308.93, 308.94, 308.95, 308.96, 308.97, 308.98, 308.99, 309.00, 309.01, 309.02, 309.03, 309.04, 309.05, 309.06, 309.07, 309.08, 309.09, 309.10, 309.11, 309.12, 309.13, 309.14, 309.15, 309.16, 309.17, 309.18, 309.19, 309.20, 309.21, 309.22, 309.23, 309.24, 309.25, 309.26, 309.27, 309.28, 309.29, 309.30, 309.31, 309.32, 309.33, 309.34, 309.35, 309.36, 309.37, 309.38, 309.39, 309.40, 309.41, 309.42, 309.43, 309.44, 309.45, 309.46, 309.47, 309.48, 309.49, 309.50, 309.51, 309.52, 309.53, 309.54, 309.55, 309.56, 309.57, 309.58, 309.59, 309.60, 309.61, 309.62, 309.63, 309.64, 309.65, 309.66, 309.67, 309.68, 309.69, 309.70, 309.71, 309.72, 309.73, 309.74, 309.75, 309.76, 309.77, 309.78, 309.79, 309.80, 309.81, 309.82, 309.83, 309.84, 309.85, 309.86, 309.87, 309.88, 309.89, 309.90, 309.91, 309.92, 309.93, 309.94, 309.95, 309.96, 309.97, 309.98, 309.99, 310.00	CONCRETE, REBAR, TIE BARS

**POST-INSTALLED ANCHORAGE INTO CONCRETE**

ANCHORAGE SHALL BE INSTALLED PER ACI 308.4C.

ALL ANCHORING SHALL BE PERFORMED BY A QUALIFIED CONTRACTOR AND SHALL BE APPROVED BY THE ARCHITECT.

ANCHORING SHALL BE INSTALLED PER ACI 308.4C AND SHALL COMPLY WITH SECTION 05120 OF THE SPECIFICATIONS.

ANCHORING SHALL BE INSTALLED PER ACI 308.4C AND SHALL COMPLY WITH SECTION 05120 OF THE SPECIFICATIONS.

ANCHORING SHALL BE INSTALLED PER ACI 308.4C AND SHALL COMPLY WITH SECTION 05120 OF THE SPECIFICATIONS.

ANCHORING SHALL BE INSTALLED PER ACI 308.4C AND SHALL COMPLY WITH SECTION 05120 OF THE SPECIFICATIONS.

ANCHORING SHALL BE INSTALLED PER ACI 308.4C AND SHALL COMPLY WITH SECTION 05120 OF THE SPECIFICATIONS.

ANCHORING SHALL BE INSTALLED PER ACI 308.4C AND SHALL COMPLY WITH SECTION 05120 OF THE SPECIFICATIONS.

ANCHORING SHALL BE INSTALLED PER ACI 308.4C AND SHALL COMPLY WITH SECTION 05120 OF THE SPECIFICATIONS.

ANCHORING SHALL BE INSTALLED PER ACI 308.4C AND SHALL COMPLY WITH SECTION 05120 OF THE SPECIFICATIONS.

ANCHORING SHALL BE INSTALLED PER ACI 308.4C AND SHALL COMPLY WITH SECTION 05120 OF THE SPECIFICATIONS.

ANCHORING SHALL BE INSTALLED PER ACI 308.4C AND SHALL COMPLY WITH SECTION 05120 OF THE SPECIFICATIONS.

ANCHORING SHALL BE INSTALLED PER ACI 308.4C AND SHALL COMPLY WITH SECTION 05120 OF THE SPECIFICATIONS.

**DEFERRED APPROVAL**

CONTRACTOR SHALL OBTAIN COMPLETE DESIGN PERFORMANCE BY A QUALIFIED REGISTERED ENGINEER FOR THE STRUCTURE.

DEFERRED APPROVAL

CONTRACTOR SHALL OBTAIN COMPLETE DESIGN PERFORMANCE BY A QUALIFIED REGISTERED ENGINEER FOR THE STRUCTURE.

**GENERAL NOTES**

1. GENERAL NOTES

2. GENERAL NOTES

3. GENERAL NOTES

4. GENERAL NOTES

5. GENERAL NOTES

6. GENERAL NOTES

7. GENERAL NOTES

8. GENERAL NOTES

9. GENERAL NOTES

10. GENERAL NOTES

11. GENERAL NOTES

12. GENERAL NOTES

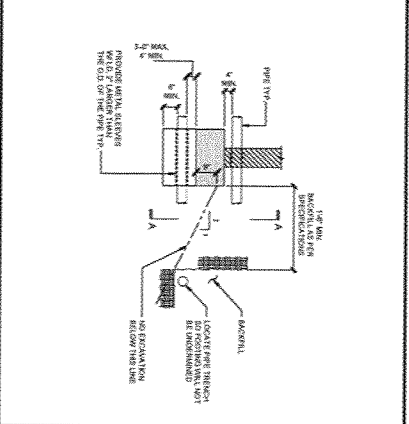
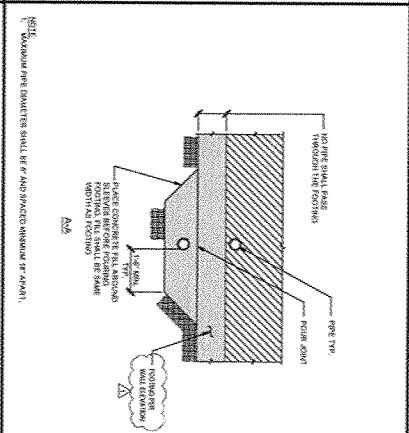
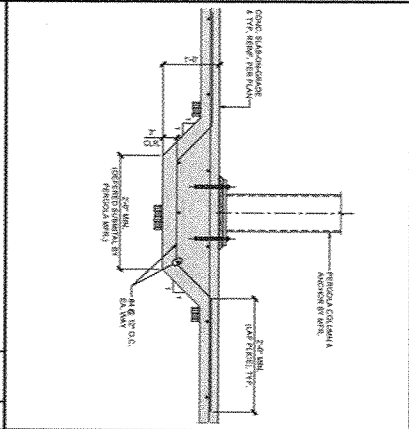
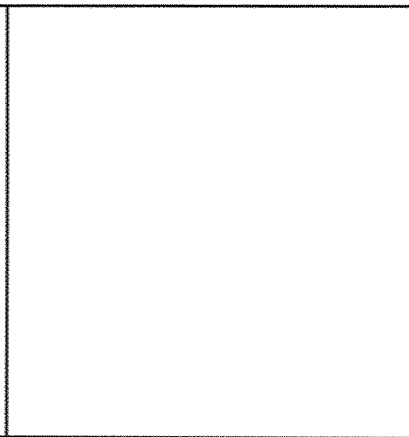
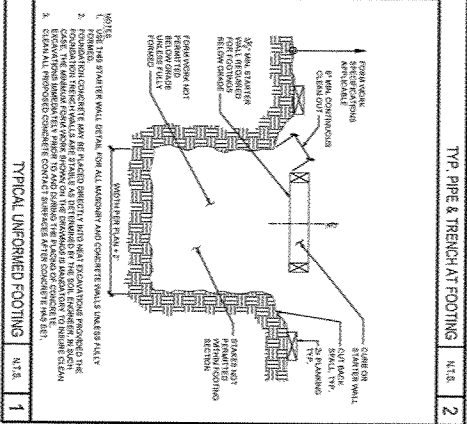
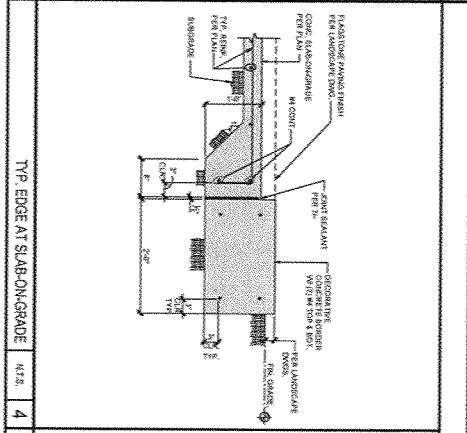
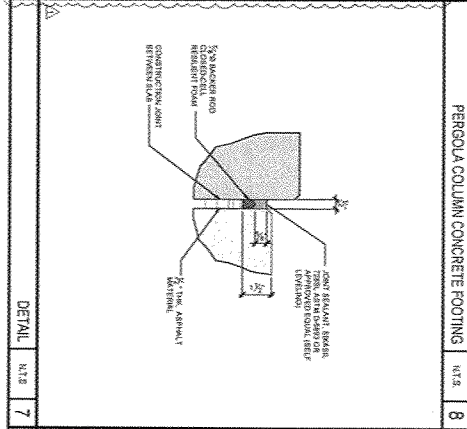
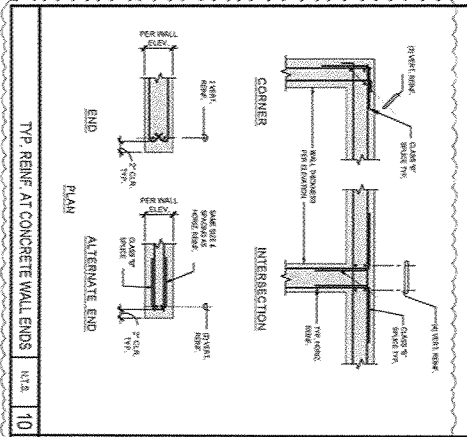

**TENSION DEVELOPMENT LENGTHS OF STANDARD HOOKS**

GRADE	BAR SIZE	MINIMUM TENSION DEVELOPMENT LENGTH (IN)
40	3/8"	400
	1/2"	500
	3/4"	600
	1"	700
60	3/8"	500
	1/2"	600
	3/4"	700
	1"	800
80	3/8"	600
	1/2"	700
	3/4"	800
	1"	900
100	3/8"	700
	1/2"	800
	3/4"	900
	1"	1000
150	3/8"	800
	1/2"	900
	3/4"	1000
	1"	1100

**NOTES:**

- ALL TENSION DEVELOPMENT LENGTHS ARE FROM FACE OF HOOK TO END OF BAR.
- MINIMUM COVER = 3"

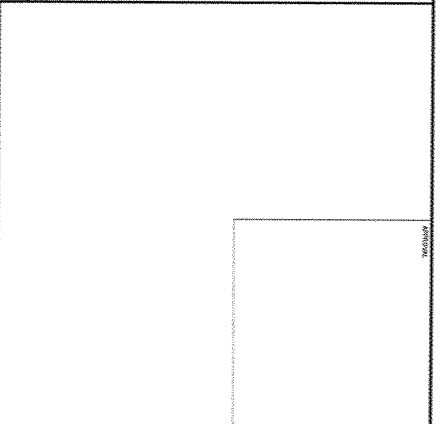
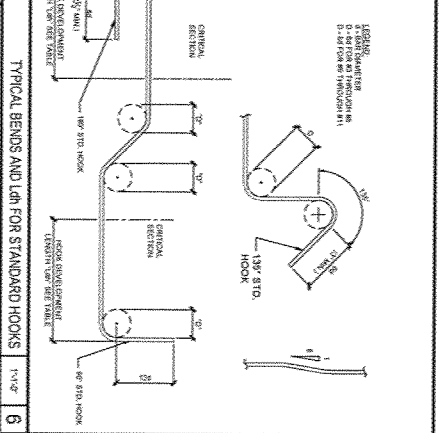
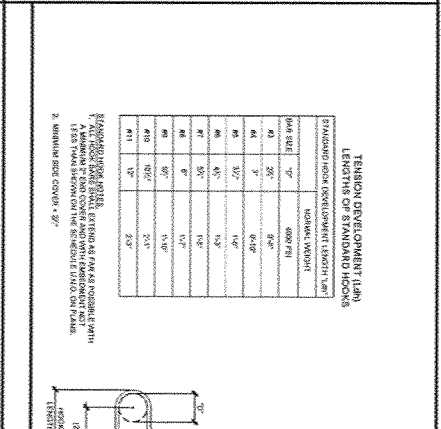

**PROJECT IDENTIFICATION**

PROJECT NO. 231117.00

DATE 03/19/24

DESIGNER EDGAR LONTOK

CHECKED BY CM WA

APPROVED BY SH

**TYPICAL DETAILS**

SHEET NO. 41 OF 53

**IDB GROUP**

1 PETER CANYON ROAD, SUITE 100  
IRVINE, CA 92618  
TEL: 949-871-6800 FAX: 949-871-6803

**placentia**  
LIBRARY + DISTRICT

411 E. CHAPMAN AVE  
PLACENTIA, CA 92870

**OUTDOOR LIBRARY**

**placentia**  
LIBRARY + DISTRICT

411 E. CHAPMAN AVE  
PLACENTIA, CA 92870

**OUTDOOR LIBRARY**

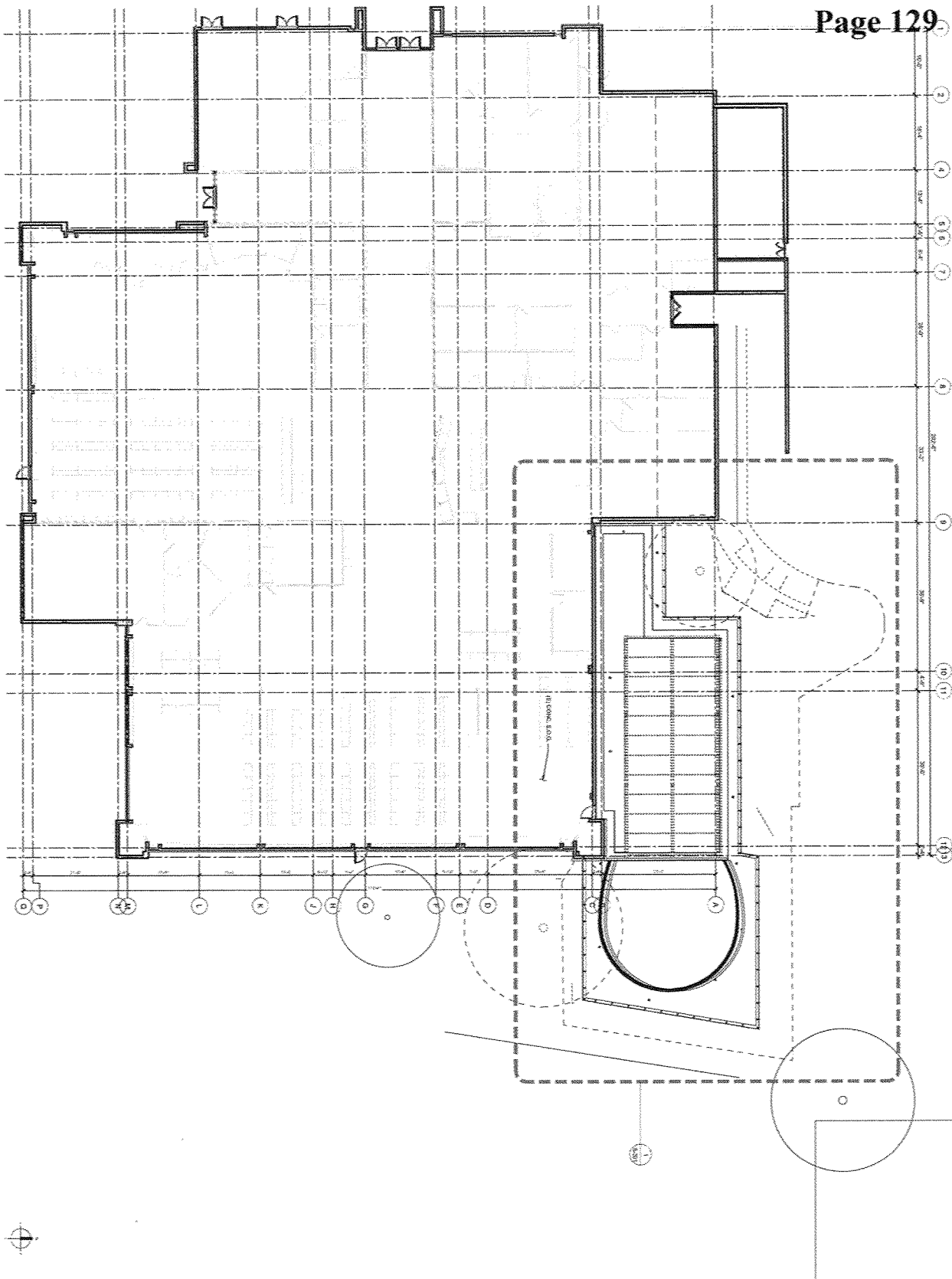

SITE PLAN  
3/24" x 1/4"  
1

 <p>CLIENT: 1500 AND GERRISH AREA 411 E. CHAPMAN AVE, PASADENA, CA 92309</p>		<p><b>OUTDOOR LIBRARY</b></p>		<p>411 E. CHAPMAN AVE. PASADENA, CA 92309</p>	
<p>PROJECT NAME</p>		<p>DATE</p>		<p>DATE SHEET: 06/19/2024</p>	
<p>PROJECT NUMBER</p>		<p>REV. DESCRIPTION</p>		<p>DATE</p>	
<p>SHEET NO. 4 OF 53</p>		<p>1 PLD CHECK SUBMITTAL</p>		<p>06/04</p>	
<p>S-101</p>		<p>2 PLD CHECK LIBRARY</p>		<p>06/04</p>	
<p>SITE PLAN</p>		<p>PROJECT IDENTIFICATION</p>		<p>PROJECT NO. 23A117.00</p>	
<p>DRAWN BY DB</p>		<p>THE ORGANIC ARCHITECTURE GROUP, INC. (OAG) IS AN EQUAL OPPORTUNITY AND AFFIRMATIVE ACTION EMPLOYER. WE DO NOT DISCRIMINATE ON THE BASIS OF RACE, GENDER, RELIGION, ETHNICITY, NATIONAL ORIGIN, SEXUAL ORIENTATION, OR ANY OTHER PROTECTED CLASS. WE ARE AN EQUAL OPPORTUNITY AND AFFIRMATIVE ACTION EMPLOYER.</p>		<p>DRAWN BY DB</p>	
<p>CHECKED BY CA, VM</p>		<p>LIBRARY DISTRICT</p>		<p>CHECKED BY CA, VM</p>	
<p>APPROVED BY SH</p>		<p>LIBRARY DISTRICT</p>		<p>APPROVED BY SH</p>	
<p>DATE</p>		<p>LIBRARY DISTRICT</p>		<p>DATE</p>	

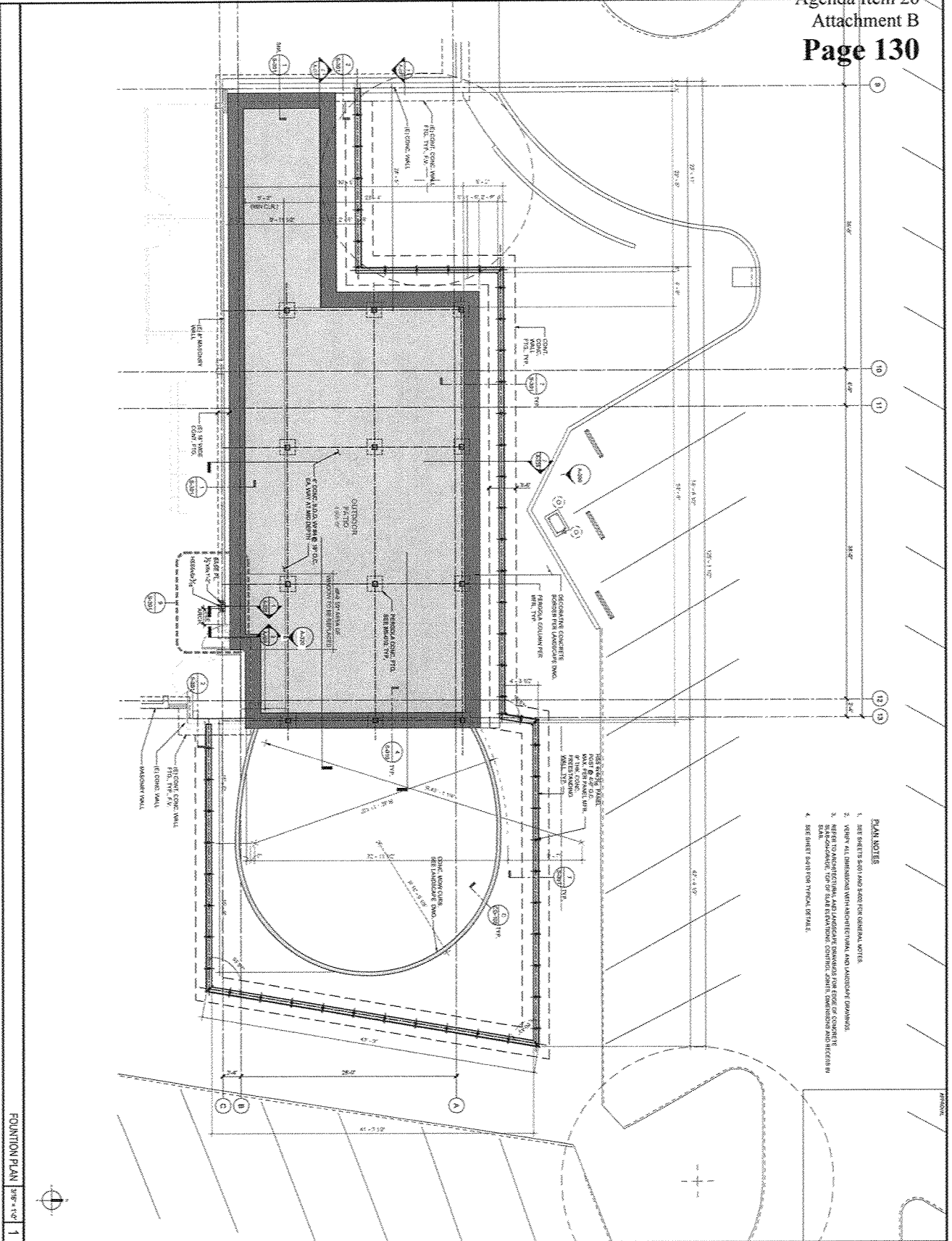

- PLAN NOTES**
1. SEE SHEETS S-201 AND S-202 FOR GENERAL NOTES.
  2. VERIFY ALL DIMENSIONS WITH ARCHITECTURAL AND LANDSCAPE DRAWINGS.
  3. REFER TO ARCHITECTURAL AND LANDSCAPE DRAWINGS FOR ELEVATION OF CONCRETE FINISHES AND FINISH OF GROUND SURFACE. VERIFY ELEVATION CONTROL POINT DIMENSIONS AND HEIGHTS IN THIS DRAWING.
  4. SEE SHEET S-201 FOR TYPICAL DETAILS.

FOUNDATION PLAN 3/8" = 1'-0" 1

		GREAT 1000 AND SUCCESS AREA 411 E. CHRYSTAL AVE. PLACENTIA, CA 92669										
<b>OUTDOOR LIBRARY</b>		411 E. CHRYSTAL AVE. PLACENTIA, CA 92669										
		1 PETER COUNTY ROAD, SUITE 130 TEL: 909.387.8855 FAX: 909.387.6880										
DATE: 08/21/2024												
<table border="1"> <thead> <tr> <th>REV.</th> <th>DESCRIPTION</th> <th>DATE</th> </tr> </thead> <tbody> <tr> <td>01</td> <td>FINAL CHECK SUBMITTAL</td> <td>08/20/24</td> </tr> <tr> <td>02</td> <td>FINAL CHECK SUBMITTAL</td> <td>08/20/24</td> </tr> </tbody> </table>	REV.	DESCRIPTION	DATE	01	FINAL CHECK SUBMITTAL	08/20/24	02	FINAL CHECK SUBMITTAL	08/20/24	PROJECT IDENTIFICATION THIS DRAWING IS THE PROPERTY OF IDS GROUP AND IS NOT TO BE REPRODUCED OR TRANSMITTED IN ANY FORM OR BY ANY MEANS, ELECTRONIC OR MECHANICAL, INCLUDING PHOTOCOPYING, RECORDING, OR BY ANY INFORMATION STORAGE AND RETRIEVAL SYSTEM, WITHOUT THE WRITTEN PERMISSION OF IDS GROUP.		
REV.	DESCRIPTION	DATE										
01	FINAL CHECK SUBMITTAL	08/20/24										
02	FINAL CHECK SUBMITTAL	08/20/24										
IDS PROJECT NO. 23A117.00												
DRAWN BY: DB												
CHECKED BY: CA, VM												
APPROVED BY: SH												
SHEET TITLE: FOUNDATION PLAN												
SHEET NO. 6 OF 51												



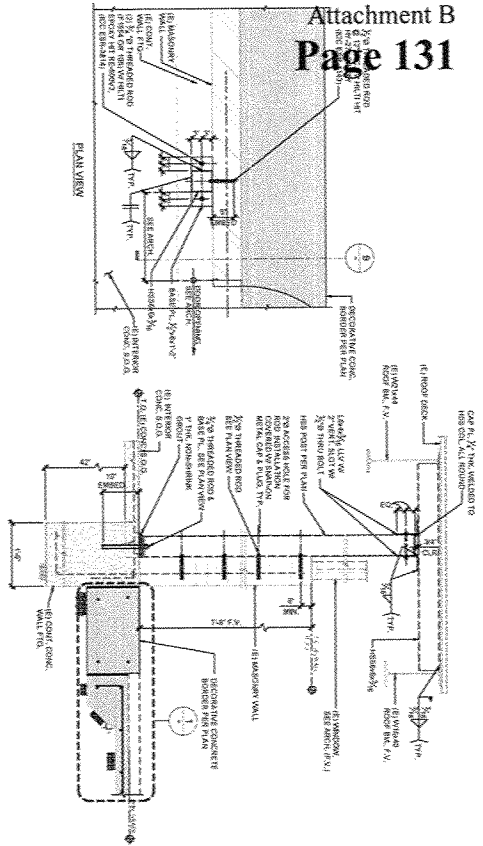

WALL SECTION 3/8" x 1/8" 9

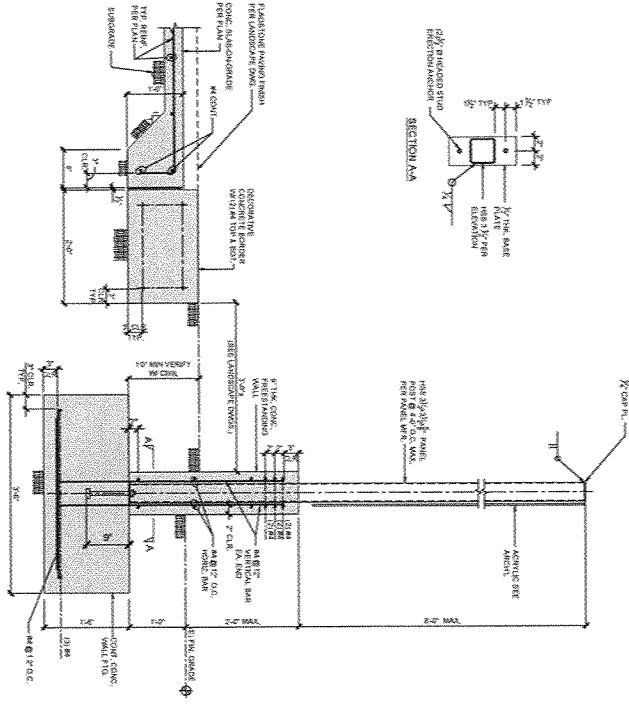

PRECASTING WALL SECTION 1" x 1/8" 7

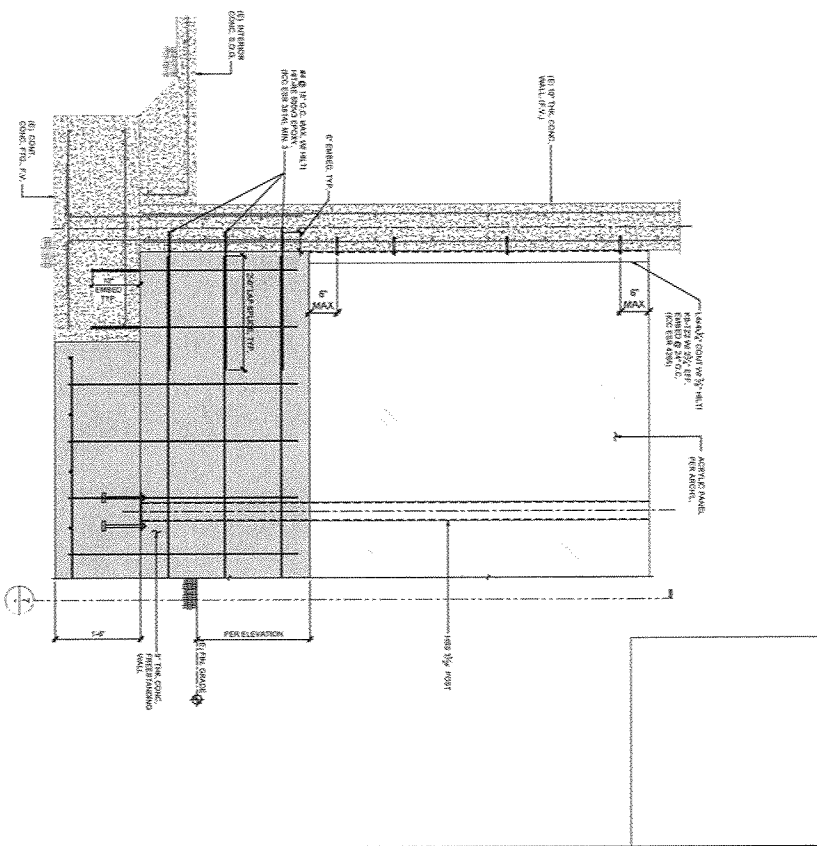

CONC. WALL TO EXIST WALL 1" x 1/8" 2

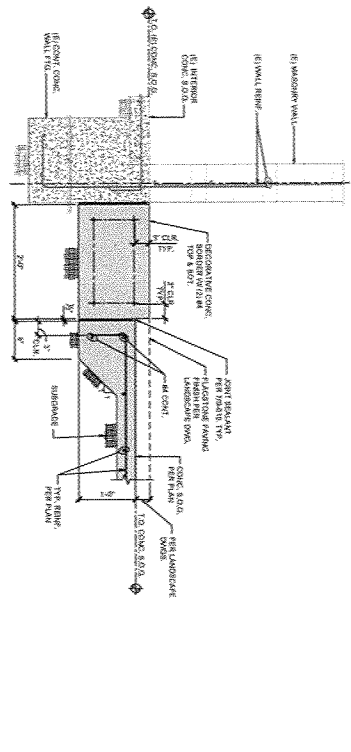

CONC. SLAB-ON-GRADE TO (E) WALL 1" x 1/8" 1



CLIENT LOGO AND ADDRESS: 411 E. CHAPMAN AVE. PLACENTIA, CA 92673

OUTDOOR LIBRARY

411 E. CHAPMAN AVE. PLACENTIA, CA 92673



1 PETER CANBERG, SUITE 150 TEL: 949.287.8800 FAX: 949.287.8800



REV.	DESCRIPTION	DATE
1	ISSUED FOR PERMITS	08/19/24
2	FOR CONSTRUCTION	08/19/24

PROJECT IDENTIFICATION  
THE DRAWING AND CONTENTS ARE THE PROPERTY OF IDS GROUP AND SHALL REMAIN THE PROPERTY OF IDS GROUP. NO PART OF THIS DRAWING OR CONTENTS SHALL BE REPRODUCED OR TRANSMITTED IN ANY FORM OR BY ANY MEANS, ELECTRONIC OR MECHANICAL, WITHOUT THE WRITTEN PERMISSION OF IDS GROUP.

DESIGNER: EDGAR LOANTOC  
CHECKED BY: CM, VA  
APPROVED BY: SH  
SHEET NO. 4 OF 13

SECTIONS AND DETAILS  
S-301

1. THESE STANDARDS AND SPECIFICATIONS TO ESTABLISH A BASIS OF DESIGN FOR THE ELECTRICAL SYSTEM. THE CONTRACTOR SHALL BE RESPONSIBLE FOR OBTAINING THE NECESSARY PERMITS AND APPROVALS FROM THE CITY OF PALM SPRINGS. THE CONTRACTOR SHALL BE RESPONSIBLE FOR OBTAINING THE NECESSARY PERMITS AND APPROVALS FROM THE CITY OF PALM SPRINGS.
2. ALL ELECTRICAL WORK SHALL BE PERFORMED IN ACCORDANCE WITH THE NATIONAL ELECTRICAL CODE (NEC) AND ALL CITY CODES AND ORDINANCES. THE CONTRACTOR SHALL BE RESPONSIBLE FOR OBTAINING THE NECESSARY PERMITS AND APPROVALS FROM THE CITY OF PALM SPRINGS.
3. THE CONTRACTOR SHALL BE RESPONSIBLE FOR OBTAINING THE NECESSARY PERMITS AND APPROVALS FROM THE CITY OF PALM SPRINGS.
4. THE CONTRACTOR SHALL BE RESPONSIBLE FOR OBTAINING THE NECESSARY PERMITS AND APPROVALS FROM THE CITY OF PALM SPRINGS.
5. THE CONTRACTOR SHALL BE RESPONSIBLE FOR OBTAINING THE NECESSARY PERMITS AND APPROVALS FROM THE CITY OF PALM SPRINGS.
6. THE CONTRACTOR SHALL BE RESPONSIBLE FOR OBTAINING THE NECESSARY PERMITS AND APPROVALS FROM THE CITY OF PALM SPRINGS.
7. THE CONTRACTOR SHALL BE RESPONSIBLE FOR OBTAINING THE NECESSARY PERMITS AND APPROVALS FROM THE CITY OF PALM SPRINGS.
8. THE CONTRACTOR SHALL BE RESPONSIBLE FOR OBTAINING THE NECESSARY PERMITS AND APPROVALS FROM THE CITY OF PALM SPRINGS.
9. THE CONTRACTOR SHALL BE RESPONSIBLE FOR OBTAINING THE NECESSARY PERMITS AND APPROVALS FROM THE CITY OF PALM SPRINGS.
10. THE CONTRACTOR SHALL BE RESPONSIBLE FOR OBTAINING THE NECESSARY PERMITS AND APPROVALS FROM THE CITY OF PALM SPRINGS.

ELECTRICAL SYMBOL LIST

POWER	LIGHTING

**POWER**  
 BREAKER, JUNCTION BOX, PANEL, etc.  
**LIGHTING**  
 LIGHT FIXTURE, SWITCH, etc.

**STANDARD ABBREVIATIONS**  
 A - ABBREVIATION  
 B - ABBREVIATION  
 C - ABBREVIATION  
 D - ABBREVIATION  
 E - ABBREVIATION  
 F - ABBREVIATION  
 G - ABBREVIATION  
 H - ABBREVIATION  
 I - ABBREVIATION  
 J - ABBREVIATION  
 K - ABBREVIATION  
 L - ABBREVIATION  
 M - ABBREVIATION  
 N - ABBREVIATION  
 O - ABBREVIATION  
 P - ABBREVIATION  
 Q - ABBREVIATION  
 R - ABBREVIATION  
 S - ABBREVIATION  
 T - ABBREVIATION  
 U - ABBREVIATION  
 V - ABBREVIATION  
 W - ABBREVIATION  
 X - ABBREVIATION  
 Y - ABBREVIATION  
 Z - ABBREVIATION

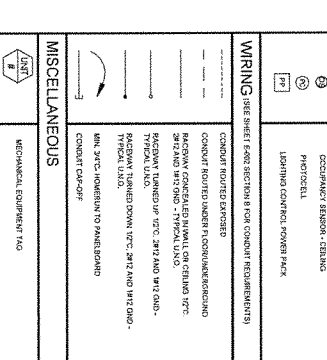
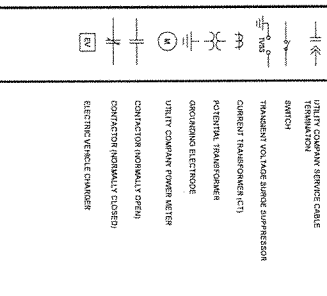

**APPLICABLE CODES**

- 2022 CALIFORNIA ELECTRICAL CODE (CALIF. E.C.C.)
- 2022 CALIFORNIA MECHANICAL CODE (CALIF. M.C.C.)
- 2022 CALIFORNIA PLUMBING CODE (CALIF. P.C.C.)
- 2022 CALIFORNIA FIRE CODE (CALIF. F.C.C.)
- 2022 CALIFORNIA BUILDING CODE (CALIF. B.C.C.)
- 2022 CALIFORNIA FIRE ALARM CODE (CALIF. F.A.C.)
- 2022 CALIFORNIA FIRE DETECTOR CODE (CALIF. F.D.C.)
- 2022 CALIFORNIA FIRE EXTINGUISHER CODE (CALIF. F.E.C.)
- 2022 CALIFORNIA FIRE SMOKE DETECTOR CODE (CALIF. F.S.D.C.)
- 2022 CALIFORNIA FIRE SMOKE DETECTOR ALARM CODE (CALIF. F.S.D.A.C.)
- 2022 CALIFORNIA FIRE SMOKE DETECTOR ALARM AND NOTIFICATION CODE (CALIF. F.S.D.A.N.C.)
- 2022 CALIFORNIA FIRE SMOKE DETECTOR ALARM AND NOTIFICATION AND COMMUNICATION CODE (CALIF. F.S.D.A.N.C.C.)
- 2022 CALIFORNIA FIRE SMOKE DETECTOR ALARM AND NOTIFICATION AND COMMUNICATION AND COMMUNICATION CODE (CALIF. F.S.D.A.N.C.C.C.)
- 2022 CALIFORNIA FIRE SMOKE DETECTOR ALARM AND NOTIFICATION AND COMMUNICATION AND COMMUNICATION AND COMMUNICATION CODE (CALIF. F.S.D.A.N.C.C.C.C.)

**placentia**  
LIBRARY DISTRICT

CLIENT AND ADDRESS AREA  
411 E CHAPMAN AVE. PLACENTIA, CA 92670

**OUTDOOR LIBRARY**

IDS GROUP  
1 PETERS CANYON ROAD, SUITE 100  
IRVINE, CA 92618  
TEL: 949-261-6500, FAX: 949-261-2890

PROJECT NO: 23111.00  
SHEET NO: OF 33

**E-001**  
GENERAL NOTES,  
SYMBOL LIST &  
SHEET INDEX

NO.	DESCRIPTION	DATE
1	ISSUED FOR PERMITTING	06/01/24
2	ISSUED FOR PERMITTING	06/01/24
3	ISSUED FOR PERMITTING	06/01/24
4	ISSUED FOR PERMITTING	06/01/24
5	ISSUED FOR PERMITTING	06/01/24
6	ISSUED FOR PERMITTING	06/01/24
7	ISSUED FOR PERMITTING	06/01/24
8	ISSUED FOR PERMITTING	06/01/24
9	ISSUED FOR PERMITTING	06/01/24
10	ISSUED FOR PERMITTING	06/01/24

**PROJECT IDENTIFICATION**

PROJECT NO: 23111.00  
 SHEET NO: E-001

**DESIGNER**  
IDS GROUP

**DATE**  
06/01/24

**PROJECT IDENTIFICATION**  
 PROJECT NO: 23111.00  
 SHEET NO: E-001

**DESIGNER**  
IDS GROUP

**DATE**  
06/01/24







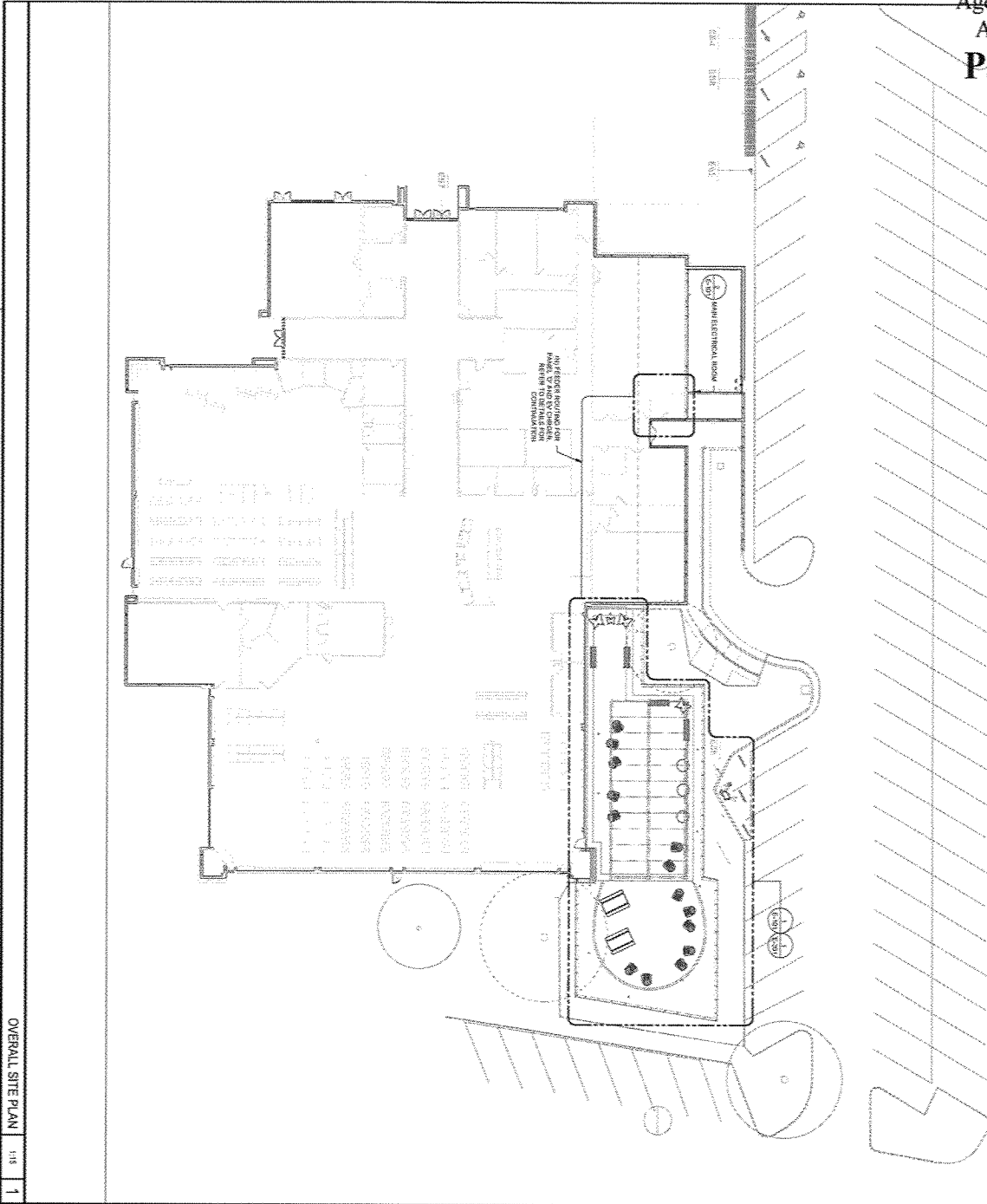

OVERALL SITE PLAN 1/8 1

**SITE PLAN GENERAL NOTES**

1. REFER TO SHEET E-100 FOR GENERAL NOTES AND SPECIFICATIONS.
2. REFER TO SHEET E-101 FOR ELECTRICAL AND MECHANICAL SPECIFICATIONS.
3. REFER TO SHEET E-102 FOR PLUMBING AND MECHANICAL SPECIFICATIONS.
4. REFER TO SHEET E-103 FOR STRUCTURAL AND FOUNDATION SPECIFICATIONS.
5. REFER TO SHEET E-104 FOR CIVIL AND LANDSCAPE ARCHITECTURE SPECIFICATIONS.
6. REFER TO SHEET E-105 FOR INTERIOR ARCHITECTURE SPECIFICATIONS.
7. REFER TO SHEET E-106 FOR EXTERIOR ARCHITECTURE SPECIFICATIONS.
8. REFER TO SHEET E-107 FOR SIGNAGE AND GRAPHIC DESIGN SPECIFICATIONS.
9. REFER TO SHEET E-108 FOR FURNITURE AND FIXTURE SPECIFICATIONS.
10. REFER TO SHEET E-109 FOR SPECIALTY MILLWORK SPECIFICATIONS.
11. REFER TO SHEET E-110 FOR SPECIALTY GLASS AND GLAZING SPECIFICATIONS.

**OUTDOOR LIBRARY**



411 E. CHAMPAIGN AVENUE  
PLACENTIA, CA 92679



1 FETTER CANYON ROAD SUITE 130  
IRVINE, CA 92618  
TEL: 949-261-9500, FAX: 949-261-2800

Professional Engineer Seal for Alan Lopez, No. 51888, State of California, License No. 51888, dated 08/20/2024.

NO.	DESCRIPTION	DATE
1	PRELIMINARY DESIGN	08/20/24
2	FINAL DESIGN	08/20/24

**PROJECT IDENTIFICATION**

PROJECT NO. 23X117.00

ISSUE NO. 01

SHEET NO. E-100 OF 53

**OVERALL SITE PLAN**

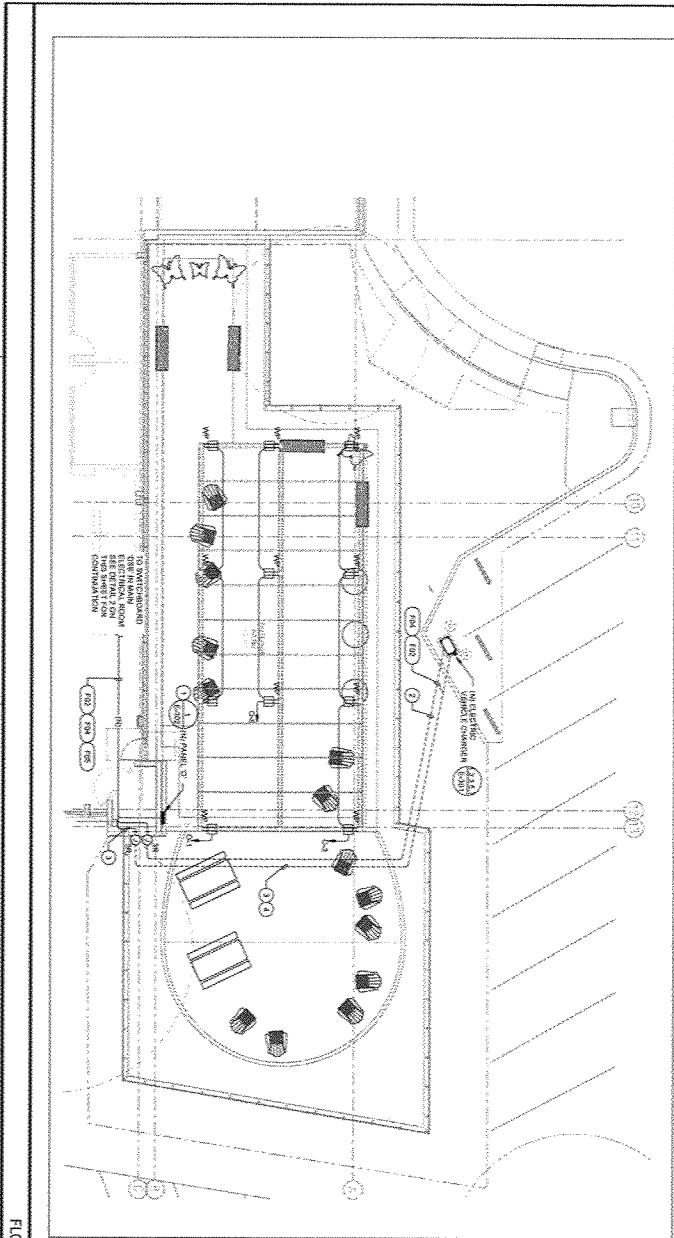

MAIN ELECTRICAL ROOM

1/8" = 1'-0" 2

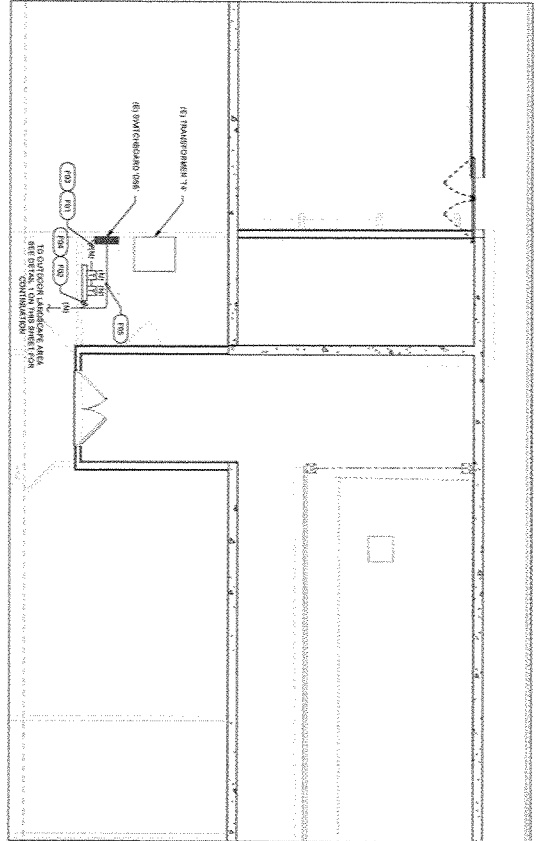

TO OUTDOOR LIBRARY AREA

1/8" = 1'-0" 2

FLOOR PLAN

1/8" = 1'-0" 1

GENERAL NOTES

1. REFER TO ALL OTHER ELECTRICAL AND MECHANICAL DRAWINGS FOR ALL OTHER NOTES AND SPECIFICATIONS.
2. ALL ELECTRICAL WORK SHALL BE IN ACCORDANCE WITH THE 2020 NATIONAL ELECTRICAL CODE (NEC) AND ALL LOCAL ORDINANCES.
3. ALL ELECTRICAL WORK SHALL BE INSTALLED IN ACCORDANCE WITH THE 2020 NATIONAL ELECTRICAL CODE (NEC) AND ALL LOCAL ORDINANCES.
4. ALL ELECTRICAL WORK SHALL BE INSTALLED IN ACCORDANCE WITH THE 2020 NATIONAL ELECTRICAL CODE (NEC) AND ALL LOCAL ORDINANCES.
5. ALL ELECTRICAL WORK SHALL BE INSTALLED IN ACCORDANCE WITH THE 2020 NATIONAL ELECTRICAL CODE (NEC) AND ALL LOCAL ORDINANCES.
6. ALL ELECTRICAL WORK SHALL BE INSTALLED IN ACCORDANCE WITH THE 2020 NATIONAL ELECTRICAL CODE (NEC) AND ALL LOCAL ORDINANCES.
7. ALL ELECTRICAL WORK SHALL BE INSTALLED IN ACCORDANCE WITH THE 2020 NATIONAL ELECTRICAL CODE (NEC) AND ALL LOCAL ORDINANCES.
8. ALL ELECTRICAL WORK SHALL BE INSTALLED IN ACCORDANCE WITH THE 2020 NATIONAL ELECTRICAL CODE (NEC) AND ALL LOCAL ORDINANCES.
9. ALL ELECTRICAL WORK SHALL BE INSTALLED IN ACCORDANCE WITH THE 2020 NATIONAL ELECTRICAL CODE (NEC) AND ALL LOCAL ORDINANCES.
10. ALL ELECTRICAL WORK SHALL BE INSTALLED IN ACCORDANCE WITH THE 2020 NATIONAL ELECTRICAL CODE (NEC) AND ALL LOCAL ORDINANCES.
11. BRACKETS AND ALL OTHER ELECTRICAL WORK SHALL BE INSTALLED IN ACCORDANCE WITH THE 2020 NATIONAL ELECTRICAL CODE (NEC) AND ALL LOCAL ORDINANCES.
12. ALL ELECTRICAL WORK SHALL BE INSTALLED IN ACCORDANCE WITH THE 2020 NATIONAL ELECTRICAL CODE (NEC) AND ALL LOCAL ORDINANCES.

KEY NOTES

1. NEW SIGNALS TO FIELD FROM MAIN ELECTRICAL ROOM. SEE SHEET E-102 FOR DETAILS.
2. REFER TO ALL OTHER ELECTRICAL AND MECHANICAL DRAWINGS FOR ALL OTHER NOTES AND SPECIFICATIONS.
3. ALL ELECTRICAL WORK SHALL BE IN ACCORDANCE WITH THE 2020 NATIONAL ELECTRICAL CODE (NEC) AND ALL LOCAL ORDINANCES.
4. ALL ELECTRICAL WORK SHALL BE INSTALLED IN ACCORDANCE WITH THE 2020 NATIONAL ELECTRICAL CODE (NEC) AND ALL LOCAL ORDINANCES.

		411 E. GARDEN AVE. PLACENTIA, CA 92786 PROJECT NO. 23X117.00	
<b>OUTDOOR LIBRARY</b>		IDS GROUP 1 FIFTH DAVENPORT, SUITE 130 IRVINE, CA 92618 TEL: 949.261.0200 FAX: 949.261.0200	
PROJECT IDENTIFICATION THE OWNER IS PLACENTIA LIBRARY DISTRICT. THE OWNER'S USE OF THIS DRAWING IS LIMITED TO THE PROJECT AND SITE SPECIFICALLY IDENTIFIED HEREIN. THE OWNER'S USE OF THIS DRAWING IS LIMITED TO THE PROJECT AND SITE SPECIFICALLY IDENTIFIED HEREIN. THE OWNER'S USE OF THIS DRAWING IS LIMITED TO THE PROJECT AND SITE SPECIFICALLY IDENTIFIED HEREIN.		PROJECT NO. 23X117.00 DRAWN BY: ANL CHECKED BY: SAC APPROVED BY: SAC	
SHEET TITLE <b>POWER FLOOR PLAN</b>		SHEET NO. OF 59	



General Specifications  
Electrical Input

Equipment	Quantity	Manufacturer	Model	Notes
Standard Power Pole	10	AMERICAN ELECTRIC	300	300V, 100A, 12.5' H
Standard Power Pole	10	AMERICAN ELECTRIC	300	300V, 100A, 12.5' H
Standard Power Pole	10	AMERICAN ELECTRIC	300	300V, 100A, 12.5' H
Standard Power Pole	10	AMERICAN ELECTRIC	300	300V, 100A, 12.5' H
Standard Power Pole	10	AMERICAN ELECTRIC	300	300V, 100A, 12.5' H
Standard Power Pole	10	AMERICAN ELECTRIC	300	300V, 100A, 12.5' H
Standard Power Pole	10	AMERICAN ELECTRIC	300	300V, 100A, 12.5' H
Standard Power Pole	10	AMERICAN ELECTRIC	300	300V, 100A, 12.5' H
Standard Power Pole	10	AMERICAN ELECTRIC	300	300V, 100A, 12.5' H
Standard Power Pole	10	AMERICAN ELECTRIC	300	300V, 100A, 12.5' H

**Panel Board Output**

Equipment	Quantity	Manufacturer	Model	Notes
Standard Panel Board	1	AMERICAN ELECTRIC	300	300V, 100A, 12.5' H
Standard Panel Board	1	AMERICAN ELECTRIC	300	300V, 100A, 12.5' H
Standard Panel Board	1	AMERICAN ELECTRIC	300	300V, 100A, 12.5' H
Standard Panel Board	1	AMERICAN ELECTRIC	300	300V, 100A, 12.5' H
Standard Panel Board	1	AMERICAN ELECTRIC	300	300V, 100A, 12.5' H
Standard Panel Board	1	AMERICAN ELECTRIC	300	300V, 100A, 12.5' H
Standard Panel Board	1	AMERICAN ELECTRIC	300	300V, 100A, 12.5' H
Standard Panel Board	1	AMERICAN ELECTRIC	300	300V, 100A, 12.5' H
Standard Panel Board	1	AMERICAN ELECTRIC	300	300V, 100A, 12.5' H
Standard Panel Board	1	AMERICAN ELECTRIC	300	300V, 100A, 12.5' H

**Function of Components**

Component	Quantity	Manufacturer	Model	Notes
Standard Component	1	AMERICAN ELECTRIC	300	300V, 100A, 12.5' H
Standard Component	1	AMERICAN ELECTRIC	300	300V, 100A, 12.5' H
Standard Component	1	AMERICAN ELECTRIC	300	300V, 100A, 12.5' H
Standard Component	1	AMERICAN ELECTRIC	300	300V, 100A, 12.5' H
Standard Component	1	AMERICAN ELECTRIC	300	300V, 100A, 12.5' H
Standard Component	1	AMERICAN ELECTRIC	300	300V, 100A, 12.5' H
Standard Component	1	AMERICAN ELECTRIC	300	300V, 100A, 12.5' H
Standard Component	1	AMERICAN ELECTRIC	300	300V, 100A, 12.5' H
Standard Component	1	AMERICAN ELECTRIC	300	300V, 100A, 12.5' H
Standard Component	1	AMERICAN ELECTRIC	300	300V, 100A, 12.5' H

**Safety and Connectivity Features**

Grounding and Bonding: All equipment shall be grounded and bonded in accordance with the National Electrical Code (NEC) and local codes.

Labeling: All equipment shall be clearly labeled with voltage, current, and other relevant information.

Access: All equipment shall be accessible in accordance with the National Electrical Code (NEC) and local codes.

Clearance: All equipment shall be installed with the required clearance from other equipment and structures.

Weather Protection: All outdoor equipment shall be protected from weather conditions.

Locking: All equipment shall be lockable to prevent unauthorized access.

Warning: All equipment shall be clearly marked with warning signs.

Documentation: All equipment shall be documented with a detailed inventory list.

Compliance: All equipment shall comply with all applicable codes and standards.

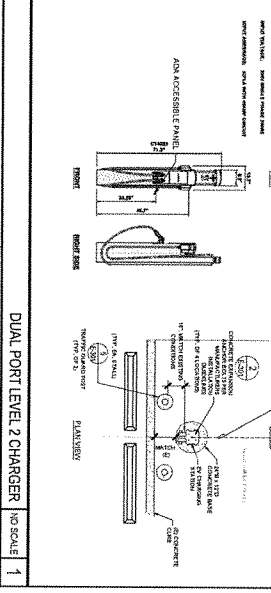
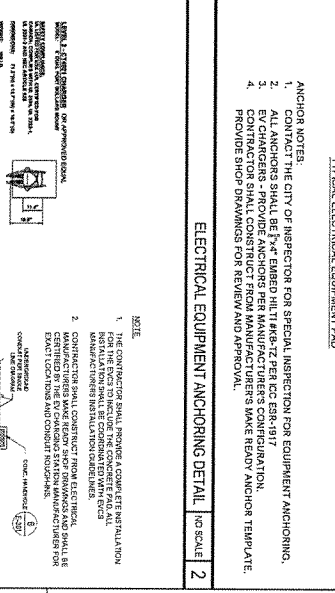
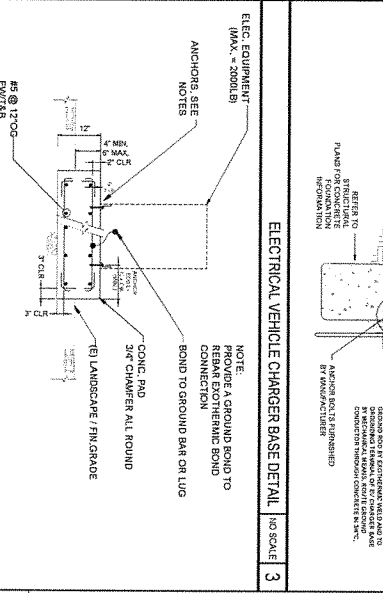
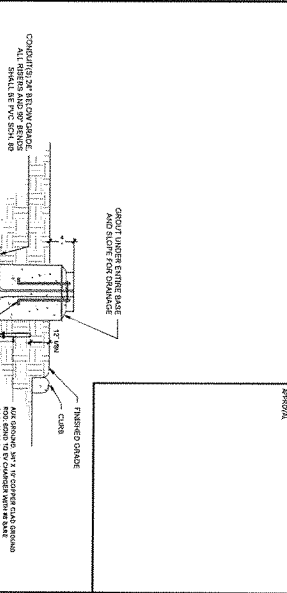
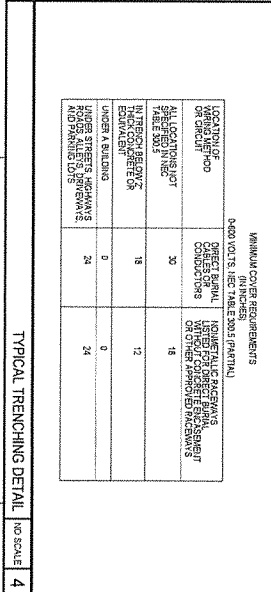
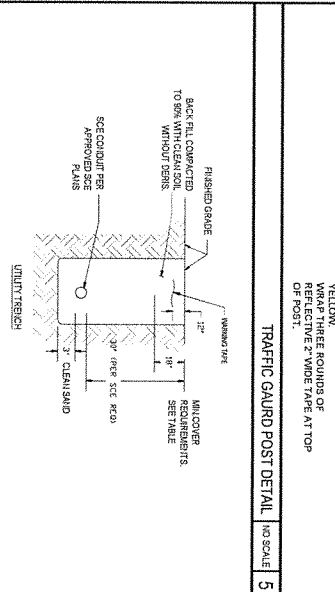
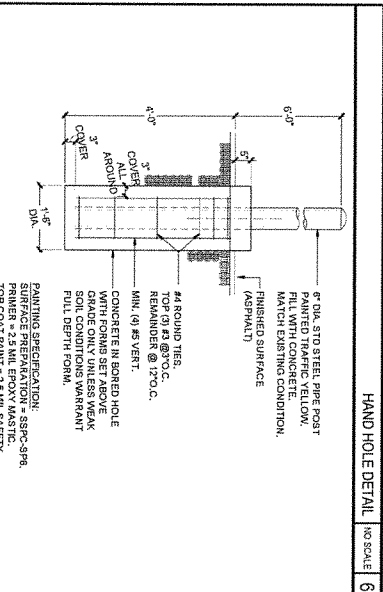
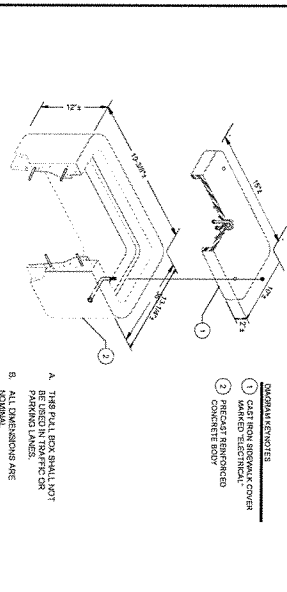

**placentia**  
LIBRARY DISTRICT

411 E. CHAPMAN AVE.  
PLACENTIA, CA 92870

**OUTDOOR LIBRARY**

**MIDS GROUP**

411 E. CHAPMAN AVE.  
PLACENTIA, CA 92870

**PROJECT IDENTIFICATION**

PROJECT NO. 23X117.00

DATE: 08/20/2024

**PROJECT IDENTIFICATION**

PROJECT NO. 23X117.00

DATE: 08/20/2024

**PROJECT IDENTIFICATION**

PROJECT NO. 23X117.00

DATE: 08/20/2024

**PROJECT IDENTIFICATION**

PROJECT NO. 23X117.00

DATE: 08/20/2024

**ELECTRICAL DETAILS**

SHEET NO. E-301

OF 33

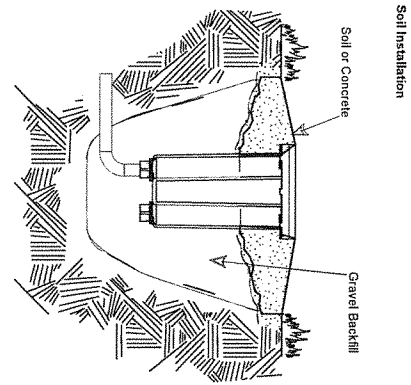

Note: Create an area around fixture to prevent collapse or debris from subsiding with light output.

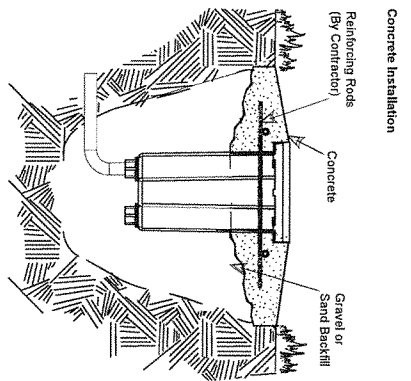

FIGURE TYPE B INSTALLATION DETAIL

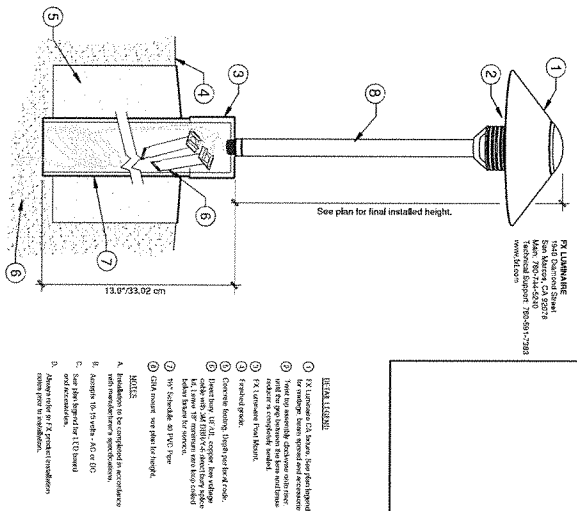

FIGURE TYPE C POLE MOUNT INSTALLATION DETAIL

- ITEMS LISTED:**
1. 1/2" diameter O.D. pipe, 1/2" thick wall
  2. 1/2" diameter O.D. pipe, 1/2" thick wall
  3. 1/2" diameter O.D. pipe, 1/2" thick wall
  4. 1/2" diameter O.D. pipe, 1/2" thick wall
  5. 1/2" diameter O.D. pipe, 1/2" thick wall
  6. 1/2" diameter O.D. pipe, 1/2" thick wall
  7. 1/2" diameter O.D. pipe, 1/2" thick wall
  8. 1/2" diameter O.D. pipe, 1/2" thick wall
- NOTES:**
1. Installation to be completed in accordance with manufacturer's instructions.
  2. All piping to be galvanized steel.
  3. All piping to be supported by 1/2" diameter O.D. pipe.
  4. All piping to be supported by 1/2" diameter O.D. pipe.
  5. All piping to be supported by 1/2" diameter O.D. pipe.
  6. All piping to be supported by 1/2" diameter O.D. pipe.
  7. All piping to be supported by 1/2" diameter O.D. pipe.
  8. All piping to be supported by 1/2" diameter O.D. pipe.

**ST-UVV SPECIFICATIONS**

**Output:**

Input Power: 60-250WAC  
Output Power: 10-40WDC  
Input Voltage: 120VAC  
Output Voltage: 5VDC

**Material:**

Material: Aluminum  
Finish: Anodized  
Color: Silver

**Dimensions:**

Height: 1.5" (38mm)  
Width: 1.5" (38mm)  
Depth: 1.5" (38mm)

**Applications:**

Applications: Emergency lighting, backup power, low-voltage lighting.

**UL Listed:**

UL Listed: E-Listed, Class 2, Limited Power Source

**TORK DT5 SERIES MULTIPURPOSE CONTINUOUS 1.2 OR 4 CHANNELS/5/7 DAY ADVANCE TIME SWITCH**

**FEATURES:**

- 1.2 or 4 channels
- 5 or 7 day advance time switch
- 1.2 or 4 channels
- 5 or 7 day advance time switch

**APPLICATIONS:**

Applications: Commercial buildings, parking lots, industrial facilities.

**INSTALLATION:**

Installation: Mount to a wall or ceiling. Requires a 120VAC power source.

**WARRANTY:**

Warranty: 3-year limited warranty.

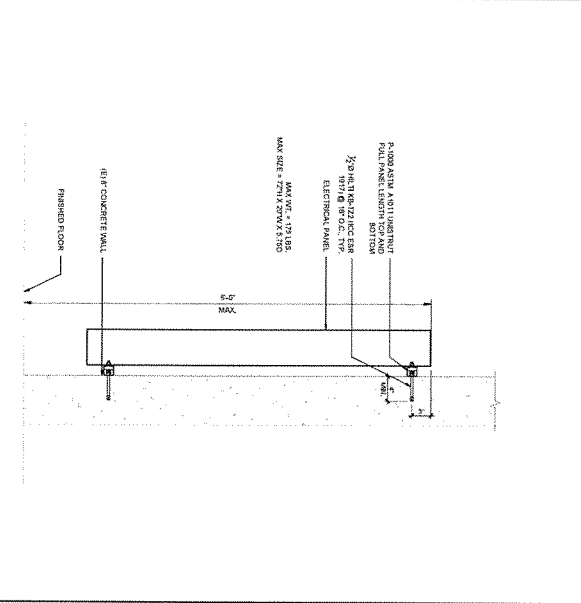
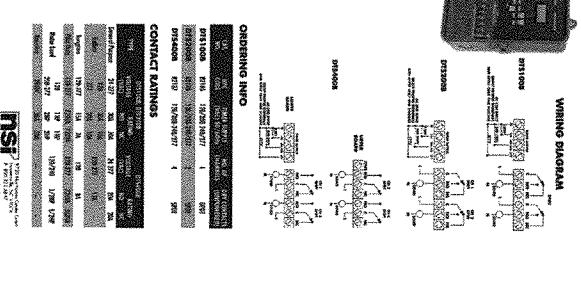

LIGHTING TRANSFORMER SPECIFICATIONS

NO SCALE 5

TIME CLOCK SPECIFICATIONS

NO SCALE 3

PANELBOARD MOUNTED ON CONCRETE WALL

NO SCALE 1

<p><b>CLIENT LOGO AND ADDRESS AREA</b></p> <p>411 E. CHAPMAN AVE PLACENTIA, CA 92870</p> <p><b>placentia</b> LIBRARY DISTRICT</p>	<p><b>PROJECT NAME</b></p> <p>OUTDOOR LIBRARY</p>	<p><b>OWNER</b></p> <p>IDS GROUP</p> <p>1 FLETCHER CANYON ROAD, SUITE 130 IRVINE, CA 92606 TEL: 949-967-4800 FAX: 949-967-0800</p>	<p><b>DESIGNER/ARCHITECT</b></p> <p>IDS GROUP</p>	<p><b>DATE</b></p> <p>8/20/2024</p>	<p><b>PROJECT IDENTIFICATION</b></p> <p>PROJECT NO. 23X117.00</p> <p>DRAWN BY: [Name]</p> <p>CHECKED BY: [Name]</p> <p>APPROVED BY: [Name]</p>	<p><b>REVISIONS</b></p> <table border="1"> <tr> <th>NO.</th> <th>DESCRIPTION</th> <th>DATE</th> </tr> <tr> <td> </td> <td> </td> <td> </td> </tr> </table>	NO.	DESCRIPTION	DATE			
NO.	DESCRIPTION	DATE										

**E-302**

SHEET NO. OF 53



**2023 TITLING**

OWNER: PLACENTA LIBRARY DISTRICT  
PROJECT NO.: 23117-00  
SHEET NO.: E-401

**1.2 REVISIONS**

NO.	REVISION	DATE	BY	CHECKED BY
1	ISSUED FOR PERMITTING	08/20/24	ALAN LOPEZ	ALAN LOPEZ
2	ISSUED FOR PERMITTING	08/20/24	ALAN LOPEZ	ALAN LOPEZ
3	ISSUED FOR PERMITTING	08/20/24	ALAN LOPEZ	ALAN LOPEZ

**2.1 MATERIALS**

NO.	DESCRIPTION	QUANTITY	UNIT
1	CONCRETE	100	YD
2	STEEL	50	TON

**2.2 MATERIALS**

NO.	DESCRIPTION	QUANTITY	UNIT
1	CONCRETE	100	YD
2	STEEL	50	TON

**2.3 MATERIALS**

NO.	DESCRIPTION	QUANTITY	UNIT
1	CONCRETE	100	YD
2	STEEL	50	TON

**1.3 ELECTRICAL REQUIREMENTS**

**1.3.1 GENERAL REQUIREMENTS**

1. ALL WIRING SHALL BE PERMITTED BY THE LOCAL AUTHORITY.

2. ALL WIRING SHALL BE IN ACCORDANCE WITH THE NATIONAL ELECTRICAL CODE (NEC) AND THE CALIFORNIA ELECTRICAL CODE (CEC).

**1.3.2 MATERIALS**

1. ALL MATERIALS SHALL BE LISTED AND APPROVED BY THE CALIFORNIA BOARD OF ELECTRICAL REGULATORY AFFAIRS (CBERA).

2. ALL MATERIALS SHALL BE INSTALLED IN ACCORDANCE WITH THE MANUFACTURER'S INSTRUCTIONS.

**1.4 ELECTRICAL REQUIREMENTS**

**1.4.1 GENERAL REQUIREMENTS**

1. ALL WIRING SHALL BE PERMITTED BY THE LOCAL AUTHORITY.

2. ALL WIRING SHALL BE IN ACCORDANCE WITH THE NATIONAL ELECTRICAL CODE (NEC) AND THE CALIFORNIA ELECTRICAL CODE (CEC).

**1.4.2 MATERIALS**

1. ALL MATERIALS SHALL BE LISTED AND APPROVED BY THE CALIFORNIA BOARD OF ELECTRICAL REGULATORY AFFAIRS (CBERA).

2. ALL MATERIALS SHALL BE INSTALLED IN ACCORDANCE WITH THE MANUFACTURER'S INSTRUCTIONS.



CLIENT: GORD AND AGNES B. AREA  
411 E. SHAWAN AVE.  
PLACENTIA, CA 92660

**PROJECT NAME**  
OUTDOOR LIBRARY

**DESIGNER**  
IDS GROUP

1 FERRIS CANYON RD, SUITE 130  
IRVINE, CA 92618  
TEL: 949-267-2800 FAX: 949-267-2800

OFFICIAL SEAL OF THE CALIFORNIA BOARD OF ELECTRICAL REGULATORY AFFAIRS

**REGISTERED PROFESSIONAL ELECTRICAL ENGINEER**  
ALAN LOPEZ  
003093

**REVISIONS**

NO.	DESCRIPTION	DATE
1	ISSUED FOR PERMITTING	08/20/24
2	ISSUED FOR PERMITTING	08/20/24

**PROJECT IDENTIFICATION**

PROJECT NO.: 23117-00  
SHEET NO.: E-401

**DESIGNED BY**  
ALAN LOPEZ

**CHECKED BY**  
SC

**APPROVED BY**  
SC

**TITLE 24 DOCUMENTATION**

**E-401**







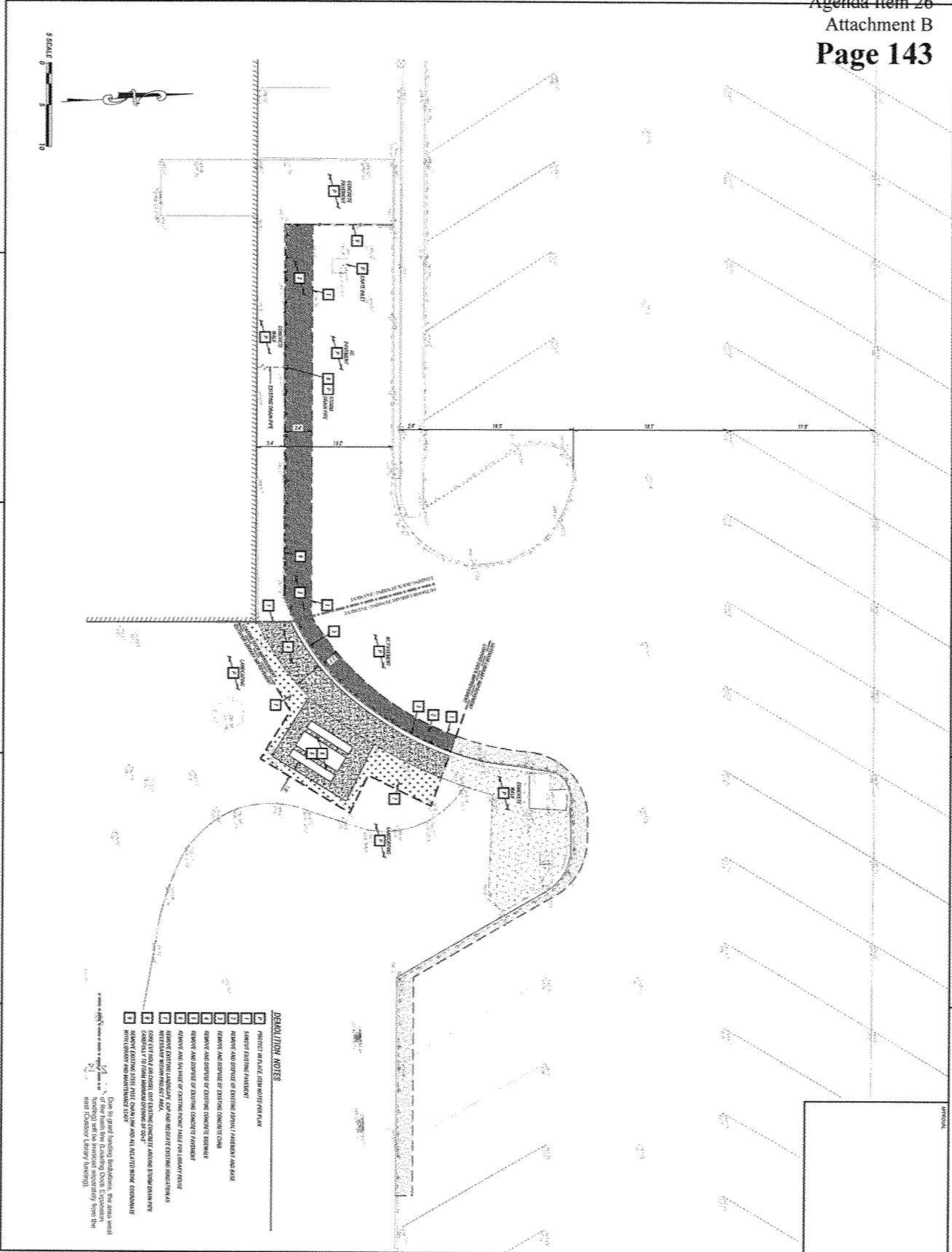



**DEMOLITION NOTES**

1. REMOVE EXISTING CONCRETE
2. REMOVE EXISTING CONCRETE
3. REMOVE EXISTING CONCRETE
4. REMOVE EXISTING CONCRETE
5. REMOVE EXISTING CONCRETE
6. REMOVE EXISTING CONCRETE
7. REMOVE EXISTING CONCRETE
8. REMOVE EXISTING CONCRETE
9. REMOVE EXISTING CONCRETE
10. REMOVE EXISTING CONCRETE
11. REMOVE EXISTING CONCRETE
12. REMOVE EXISTING CONCRETE
13. REMOVE EXISTING CONCRETE
14. REMOVE EXISTING CONCRETE
15. REMOVE EXISTING CONCRETE
16. REMOVE EXISTING CONCRETE
17. REMOVE EXISTING CONCRETE
18. REMOVE EXISTING CONCRETE
19. REMOVE EXISTING CONCRETE
20. REMOVE EXISTING CONCRETE
21. REMOVE EXISTING CONCRETE
22. REMOVE EXISTING CONCRETE

Due to great loading conditions, the area with the loading dock expansion is to be demolished and replaced with a new loading dock expansion.

	411 E. CHANANAY AVE PLACENTIA, CA 92870	<b>LOADING DOCK RAMP EXPANSION</b>	 IDS GROUP 1 PETERS CANYON ROAD, SUITE 100 IRVINE, CA 92618 TEL: 949.357.4500 FAX: 949.357.1800		SHEET NO. C-100 OF XXX
<p><b>PROJECT IDENTIFICATION</b></p> <p>PROJECT NO. 23X117.00</p> <p>CHECKED BY: AA</p> <p>APPROVED BY: AA</p>					

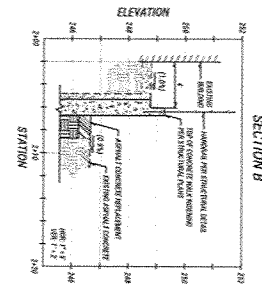
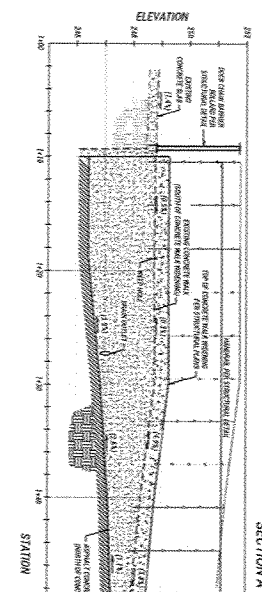
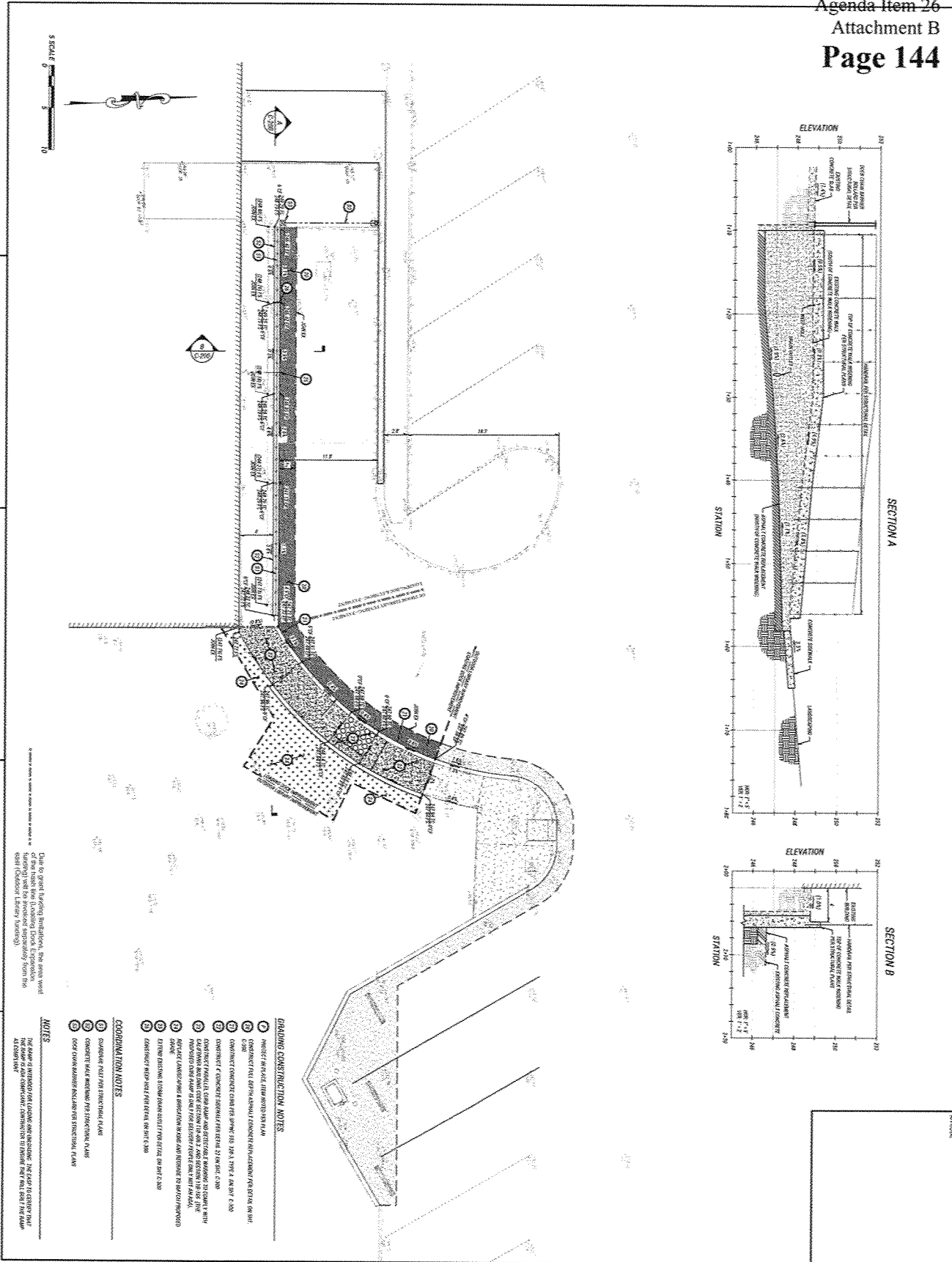

Due to street parking restrictions, the area west of the ramp will be reserved for use by the east (California Library, Inc.).

- GRADING CONSTRUCTION NOTES**
- 1. FINISH GRADE SHALL BE AS SHOWN ON THIS PLAN.
  - 2. EXISTING GRADE SHALL BE SHOWN WITH DASHED LINES.
  - 3. EXISTING CONCRETE SHALL BE REMOVED AND REPAIRED TO ORIGINAL CONDITION.
  - 4. EXISTING ASPHALT SHALL BE REPAIRED TO ORIGINAL CONDITION.
  - 5. EXISTING GRAVEL SHALL BE REPAIRED TO ORIGINAL CONDITION.
  - 6. EXISTING GRAVEL SHALL BE REPAIRED TO ORIGINAL CONDITION.
  - 7. EXISTING GRAVEL SHALL BE REPAIRED TO ORIGINAL CONDITION.
  - 8. EXISTING GRAVEL SHALL BE REPAIRED TO ORIGINAL CONDITION.
  - 9. EXISTING GRAVEL SHALL BE REPAIRED TO ORIGINAL CONDITION.
  - 10. EXISTING GRAVEL SHALL BE REPAIRED TO ORIGINAL CONDITION.
- COORDINATION NOTES**
- 1. COORDINATE WITH ALL OTHER CONTRACTORS.
  - 2. COORDINATE WITH ALL OTHER CONTRACTORS.
  - 3. COORDINATE WITH ALL OTHER CONTRACTORS.
  - 4. COORDINATE WITH ALL OTHER CONTRACTORS.
  - 5. COORDINATE WITH ALL OTHER CONTRACTORS.
  - 6. COORDINATE WITH ALL OTHER CONTRACTORS.
  - 7. COORDINATE WITH ALL OTHER CONTRACTORS.
  - 8. COORDINATE WITH ALL OTHER CONTRACTORS.
  - 9. COORDINATE WITH ALL OTHER CONTRACTORS.
  - 10. COORDINATE WITH ALL OTHER CONTRACTORS.
- NOTES**
- THE GRADING CONTRACTOR SHALL BE RESPONSIBLE FOR OBTAINING ALL NECESSARY PERMITS AND APPROVALS FROM THE LOCAL AGENCIES AND AGENCIES.

	CLIENT/CONTACT ADDRESS AREA 411 E. CHAPMAN AVE. PLACENTIA, CA 92662	<b>LOADING DOCK RAMP EXPANSION</b>	IDS GROUP 1 PIERRE CHAPMAN ROAD, SUITE 100 IRVINE, CA 92618 TEL: 949-267-8800, FAX: 949-267-8800		PROJECT IDENTIFICATION REV. DESCRIPTION DATE 1. PAVEMENT SUBMITTAL 05/02/24 2. PAVEMENT SUBMITTAL 05/02/24
<b>C-200</b>	SHEET NO. OF XXX		PROJECT IDENTIFICATION IMPROVEMENT PLANS		

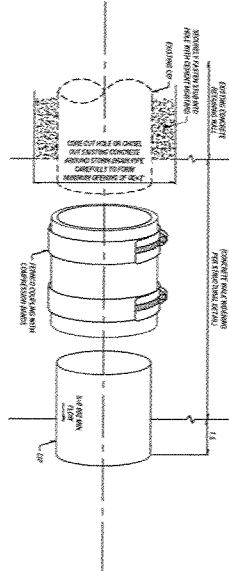

**Fainco** 1056-44 CONNECTS 4 IN. C/P/ TO 4 IN. C/P/

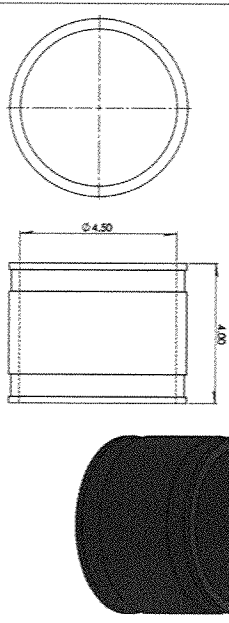

DESCRIPTION	QUANTITY	UNIT	REMARKS
STORM DRAIN OUTLET	25	MS	



**ASPHALT CONCRETE EMBANKMENT**

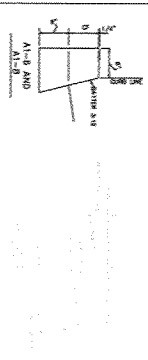

DESCRIPTION	QUANTITY	UNIT	REMARKS
CONCRETE CURB	21	MS	

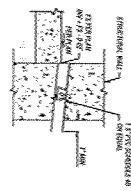

**WEEP HOLE**



**CONCRETE SIDEWALK**

	411 E CHAPMAN AVE. PLACENTIA, CA 92669
	411 E CHAPMAN AVE., PLACENTIA, CA 92669
CHART 1000 AND ADDRESS MAP	CHART 1000 AND ADDRESS MAP
PROJECT NAME <b>LOADING DOCK RAMP EXPANSION</b>	PROJECT NO. <b>C-300</b>
PROJECT NO. <b>C-300</b>	SHEET NO. OF <b>XXX</b>
PROJECT NO. <b>23X117.00</b>	SHEET NO. <b>25</b>
PROJECT NO. <b>23X117.00</b>	SHEET NO. <b>26</b>
PROJECT NO. <b>23X117.00</b>	SHEET NO. <b>27</b>
PROJECT NO. <b>23X117.00</b>	SHEET NO. <b>28</b>
PROJECT NO. <b>23X117.00</b>	SHEET NO. <b>29</b>
PROJECT NO. <b>23X117.00</b>	SHEET NO. <b>30</b>
PROJECT NO. <b>23X117.00</b>	SHEET NO. <b>31</b>
PROJECT NO. <b>23X117.00</b>	SHEET NO. <b>32</b>
PROJECT NO. <b>23X117.00</b>	SHEET NO. <b>33</b>
PROJECT NO. <b>23X117.00</b>	SHEET NO. <b>34</b>
PROJECT NO. <b>23X117.00</b>	SHEET NO. <b>35</b>
PROJECT NO. <b>23X117.00</b>	SHEET NO. <b>36</b>
PROJECT NO. <b>23X117.00</b>	SHEET NO. <b>37</b>
PROJECT NO. <b>23X117.00</b>	SHEET NO. <b>38</b>
PROJECT NO. <b>23X117.00</b>	SHEET NO. <b>39</b>
PROJECT NO. <b>23X117.00</b>	SHEET NO. <b>40</b>
PROJECT NO. <b>23X117.00</b>	SHEET NO. <b>41</b>
PROJECT NO. <b>23X117.00</b>	SHEET NO. <b>42</b>
PROJECT NO. <b>23X117.00</b>	SHEET NO. <b>43</b>
PROJECT NO. <b>23X117.00</b>	SHEET NO. <b>44</b>
PROJECT NO. <b>23X117.00</b>	SHEET NO. <b>45</b>
PROJECT NO. <b>23X117.00</b>	SHEET NO. <b>46</b>
PROJECT NO. <b>23X117.00</b>	SHEET NO. <b>47</b>
PROJECT NO. <b>23X117.00</b>	SHEET NO. <b>48</b>
PROJECT NO. <b>23X117.00</b>	SHEET NO. <b>49</b>
PROJECT NO. <b>23X117.00</b>	SHEET NO. <b>50</b>

**EROSION AND SEDIMENT CONTROL:**

1. EROSION CONTROL SHALL BE MAINTAINED THROUGHOUT THE CONSTRUCTION PERIOD FROM THE PROJECT START UNTIL THE FINAL GRADING AND PAVING IS COMPLETED.
2. EROSION CONTROL MEASURES SHALL BE INSTALLED AND MAINTAINED THROUGHOUT THE CONSTRUCTION PERIOD FROM THE PROJECT START UNTIL THE FINAL GRADING AND PAVING IS COMPLETED.
3. EROSION CONTROL MEASURES SHALL BE INSTALLED AND MAINTAINED THROUGHOUT THE CONSTRUCTION PERIOD FROM THE PROJECT START UNTIL THE FINAL GRADING AND PAVING IS COMPLETED.
4. EROSION CONTROL MEASURES SHALL BE INSTALLED AND MAINTAINED THROUGHOUT THE CONSTRUCTION PERIOD FROM THE PROJECT START UNTIL THE FINAL GRADING AND PAVING IS COMPLETED.
5. EROSION CONTROL MEASURES SHALL BE INSTALLED AND MAINTAINED THROUGHOUT THE CONSTRUCTION PERIOD FROM THE PROJECT START UNTIL THE FINAL GRADING AND PAVING IS COMPLETED.
6. EROSION CONTROL MEASURES SHALL BE INSTALLED AND MAINTAINED THROUGHOUT THE CONSTRUCTION PERIOD FROM THE PROJECT START UNTIL THE FINAL GRADING AND PAVING IS COMPLETED.
7. EROSION CONTROL MEASURES SHALL BE INSTALLED AND MAINTAINED THROUGHOUT THE CONSTRUCTION PERIOD FROM THE PROJECT START UNTIL THE FINAL GRADING AND PAVING IS COMPLETED.
8. EROSION CONTROL MEASURES SHALL BE INSTALLED AND MAINTAINED THROUGHOUT THE CONSTRUCTION PERIOD FROM THE PROJECT START UNTIL THE FINAL GRADING AND PAVING IS COMPLETED.
9. EROSION CONTROL MEASURES SHALL BE INSTALLED AND MAINTAINED THROUGHOUT THE CONSTRUCTION PERIOD FROM THE PROJECT START UNTIL THE FINAL GRADING AND PAVING IS COMPLETED.
10. EROSION CONTROL MEASURES SHALL BE INSTALLED AND MAINTAINED THROUGHOUT THE CONSTRUCTION PERIOD FROM THE PROJECT START UNTIL THE FINAL GRADING AND PAVING IS COMPLETED.

**BMP MANAGEMENT PRACTICE REFERENCE LIST:**

1. BEST MANAGEMENT PRACTICES (BMP) FOR CONSTRUCTION SITES  
 2. CONSTRUCTION BEST MANAGEMENT PRACTICES (BMP) FOR EROSION CONTROL  
 3. CONSTRUCTION BEST MANAGEMENT PRACTICES (BMP) FOR SEDIMENT CONTROL  
 4. CONSTRUCTION BEST MANAGEMENT PRACTICES (BMP) FOR WATER QUALITY PROTECTION  
 5. CONSTRUCTION BEST MANAGEMENT PRACTICES (BMP) FOR AIR QUALITY CONTROL  
 6. CONSTRUCTION BEST MANAGEMENT PRACTICES (BMP) FOR NOISE CONTROL  
 7. CONSTRUCTION BEST MANAGEMENT PRACTICES (BMP) FOR TRAFFIC CONTROL  
 8. CONSTRUCTION BEST MANAGEMENT PRACTICES (BMP) FOR PUBLIC SAFETY  
 9. CONSTRUCTION BEST MANAGEMENT PRACTICES (BMP) FOR COMMUNITY RELATIONS  
 10. CONSTRUCTION BEST MANAGEMENT PRACTICES (BMP) FOR ENVIRONMENTAL MONITORING  
 11. CONSTRUCTION BEST MANAGEMENT PRACTICES (BMP) FOR RECORD KEEPING  
 12. CONSTRUCTION BEST MANAGEMENT PRACTICES (BMP) FOR TRAINING  
 13. CONSTRUCTION BEST MANAGEMENT PRACTICES (BMP) FOR PUBLIC ACCESS  
 14. CONSTRUCTION BEST MANAGEMENT PRACTICES (BMP) FOR SECURITY  
 15. CONSTRUCTION BEST MANAGEMENT PRACTICES (BMP) FOR EMERGENCY PREPAREDNESS  
 16. CONSTRUCTION BEST MANAGEMENT PRACTICES (BMP) FOR COMPLIANCE  
 17. CONSTRUCTION BEST MANAGEMENT PRACTICES (BMP) FOR REPORTING  
 18. CONSTRUCTION BEST MANAGEMENT PRACTICES (BMP) FOR ENFORCEMENT  
 19. CONSTRUCTION BEST MANAGEMENT PRACTICES (BMP) FOR APPEALS  
 20. CONSTRUCTION BEST MANAGEMENT PRACTICES (BMP) FOR REVIEW

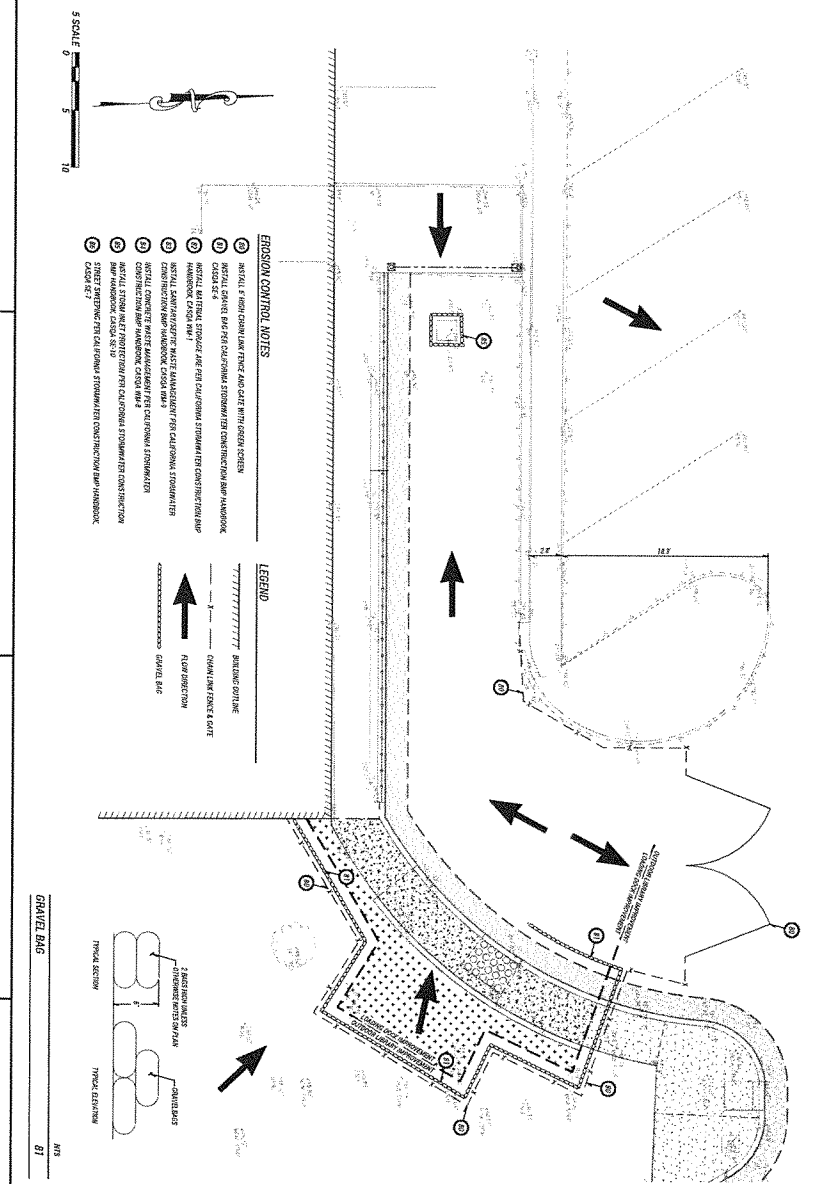

- EROSION CONTROL NOTES:**
1. INSTALL SILT FENCE AND SLOPE PROTECTION AT ALL EXPOSED EROSION CONTROL AREAS.
  2. INSTALL SILT FENCE AND SLOPE PROTECTION AT ALL EXPOSED EROSION CONTROL AREAS.
  3. INSTALL SILT FENCE AND SLOPE PROTECTION AT ALL EXPOSED EROSION CONTROL AREAS.
  4. INSTALL SILT FENCE AND SLOPE PROTECTION AT ALL EXPOSED EROSION CONTROL AREAS.
  5. INSTALL SILT FENCE AND SLOPE PROTECTION AT ALL EXPOSED EROSION CONTROL AREAS.
  6. INSTALL SILT FENCE AND SLOPE PROTECTION AT ALL EXPOSED EROSION CONTROL AREAS.
  7. INSTALL SILT FENCE AND SLOPE PROTECTION AT ALL EXPOSED EROSION CONTROL AREAS.
  8. INSTALL SILT FENCE AND SLOPE PROTECTION AT ALL EXPOSED EROSION CONTROL AREAS.
  9. INSTALL SILT FENCE AND SLOPE PROTECTION AT ALL EXPOSED EROSION CONTROL AREAS.
  10. INSTALL SILT FENCE AND SLOPE PROTECTION AT ALL EXPOSED EROSION CONTROL AREAS.

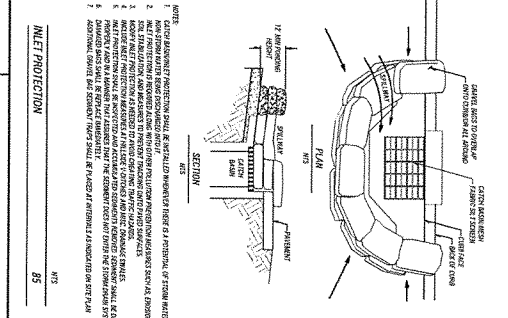
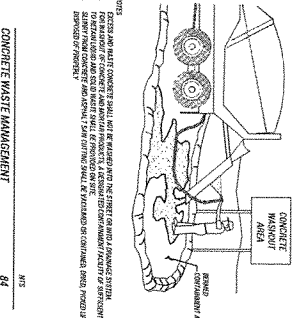
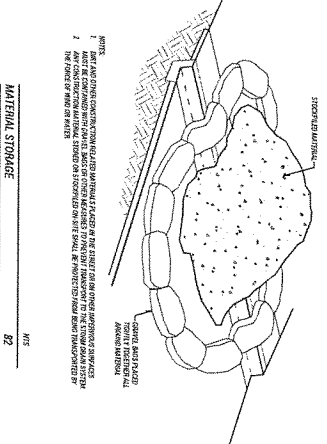
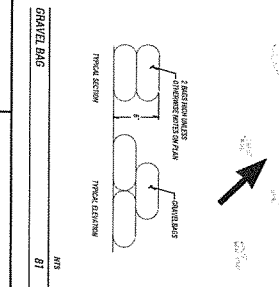
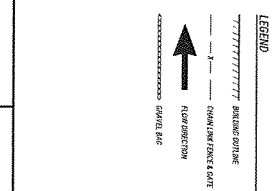

**placentia**  
LIBRARY DISTRICT

CLIENT: USDO AND ADDRESS AREA  
411 E CHAPMAN AVE, PLACENTIA, CA 92679

**LOADING DOCK  
RAMP EXPANSION**

PROJECT NAME  
411 E CHAPMAN AVE, PLACENTIA, CA 92679

IDS GROUP  
1 PETERSON CANYON ROAD, SUITE 130  
IRVINE, CA 92618  
TEL: 949.597.5500, FAX: 949.597.6800

**EROSION CONTROL PLANS AND DETAILS**

**C-400**

SHEET NUMBER  
OF XXX

SHEET NO. OF XXX

PROJECT IDENTIFICATION

REV.	DESCRIPTION	DATE
A	PLAN CHECK SUBMITTAL	03/27/24

PROJECT IDENTIFICATION

PROJECT NO. 23X117.00

DATE 03/27/24

DESIGNED BY HN

CHECKED BY JA

APPROVED BY AA









**TENSION DEVELOPMENT (LAP)  
LENGTHS OF STANDARD HOOKS**

BAR SIZE	3000 PSI	4000 PSI	5000 PSI
#3	20"	20"	20"
#4	25"	25"	25"
#5	30"	30"	30"
#6	35"	35"	35"
#7	40"	40"	40"
#8	45"	45"	45"
#9	50"	50"	50"
#10	55"	55"	55"
#11	60"	60"	60"
#12	65"	65"	65"

STANDARD TENSION DEVELOPMENT LENGTHS ARE AS SHOWN WITH A MINIMUM 7 DIA. COVER AND WITH DEVELOPMENT NOT LESS THAN 12 IN. FROM THE END OF THE BAR OR FROM THE STANDARD BEND COVER. 2"

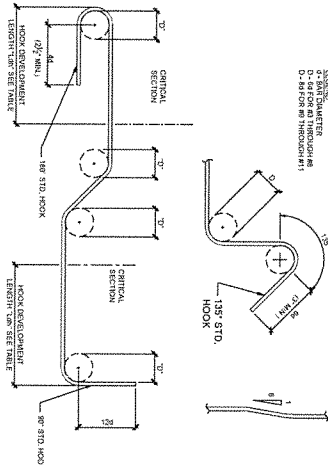

TYPICAL BENDS AND LAP FOR STANDARD HOOKS 1:1/4" 6

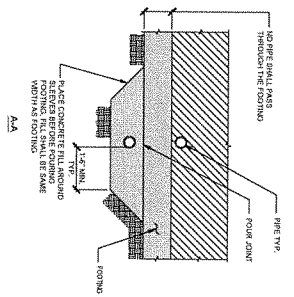

TYP. PIPE & TRENCH AT FOOTING 1:1/4" 2

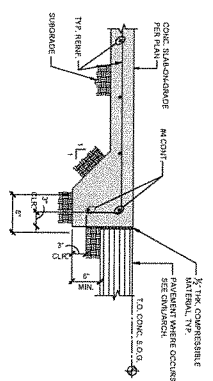

TYP. EDGE AT SUB-ON-GRADE 1:1/4" 4

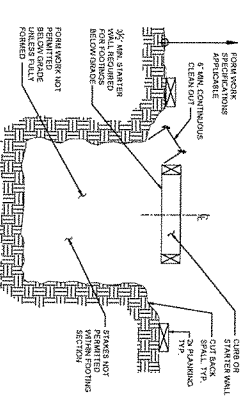

TYPICAL UNFORMED FOOTING 1:1/4" 1

**placentia**  
LIBRARY DISTRICT

CLIENT: 1000 AND ANDRESA AVE.  
411 E. CAMPANA AVE. PLACENTIA, CA 92679

**LOADING DOCK  
RAMP EXPANSION**

**IDS GROUP**

1 PETERS CANYON ROAD, SUITE 100  
IRVINE, CA 92618  
TEL: 949-397-6500, FAX: 949-397-0800

411 E. CAMPANA AVE.  
PLACENTIA, CA 92679

PROJECT NAME:  
LOADING DOCK RAMP EXPANSION

DATE: 01/26/2024

DESCRIPTION: FOUNDATION FOR SUBMITTAL

DATE: 01/26/2024

DESCRIPTION: FOUNDATION FOR SUBMITTAL

**PROJECT IDENTIFICATION**

PROJECT NO.: 23X117.00

DATE: 01/26/2024

DESCRIPTION: FOUNDATION FOR SUBMITTAL

**PROJECT IDENTIFICATION**

PROJECT NO.: 23X117.00

DATE: 01/26/2024

DESCRIPTION: FOUNDATION FOR SUBMITTAL

**PROJECT IDENTIFICATION**

PROJECT NO.: 23X117.00

DATE: 01/26/2024

DESCRIPTION: FOUNDATION FOR SUBMITTAL

**PROJECT IDENTIFICATION**

PROJECT NO.: 23X117.00

DATE: 01/26/2024

DESCRIPTION: FOUNDATION FOR SUBMITTAL

**PROJECT IDENTIFICATION**

PROJECT NO.: 23X117.00

DATE: 01/26/2024

DESCRIPTION: FOUNDATION FOR SUBMITTAL

SHEET NO. S-010 OF

TYPICAL DETAILS

DRAWN BY: DB  
CHECKED BY: CA, WA  
APPROVED BY: SH

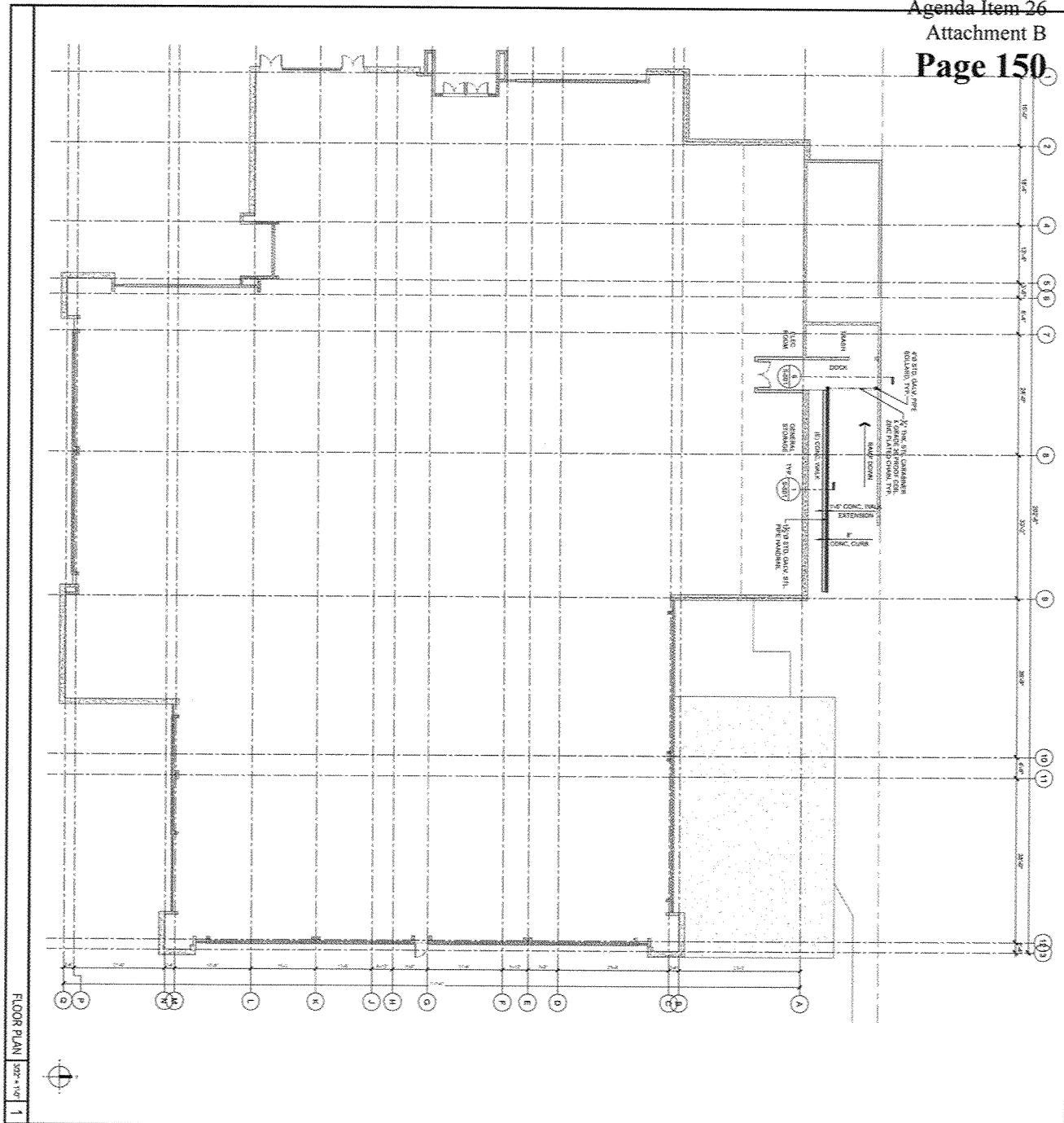

FLOOR PLAN  
 1/2\"/>

--	--	--

	<p>411 E. CHAMPAIGN AVE.                  PLACENTIA, CA 92679</p> <p><b>LOADING DOCK                  RAMP EXPANSION</b></p>	<p><b>IDS GROUP</b></p> <p>1 PETER DANFON ROAD, SUITE 100                  IRVINE, CA 92618                  TEL: 949.261.9800 FAX: 949.261.7800</p>	<p>DATE: 02/27/2024</p> <table border="1"> <thead> <tr> <th>REV.</th> <th>DESCRIPTION</th> <th>DATE</th> </tr> </thead> <tbody> <tr> <td>1</td> <td>ISSUE FOR PERMITS</td> <td>02/27/24</td> </tr> </tbody> </table> <p>PROJECT IDENTIFICATION</p> <p>THESE DRAWINGS AND SPECIFICATIONS ARE THE PROPERTY AND ORIGINAL WORK OF IDS GROUP AND SHALL REMAIN THE PROPERTY OF IDS GROUP. NO PART OF THESE DRAWINGS OR SPECIFICATIONS SHALL BE REPRODUCED OR TRANSMITTED IN ANY FORM OR BY ANY MEANS, ELECTRONIC OR MECHANICAL, INCLUDING PHOTOCOPYING, RECORDING, OR BY ANY INFORMATION STORAGE AND RETRIEVAL SYSTEM, WITHOUT THE WRITTEN PERMISSION OF IDS GROUP.</p> <p>IDS PROJECT NO. 23X117.00</p> <p>DRAWN BY: DR</p> <p>CHECKED BY: CM, VAH</p> <p>APPROVED BY: SH</p> <p>SHEET TITLE:                  FLOOR PLAN</p> <p>PROJECT NUMBER:                  S-100</p> <p>SHEET NO. 1 OF 1</p>	REV.	DESCRIPTION	DATE	1	ISSUE FOR PERMITS	02/27/24
REV.	DESCRIPTION	DATE							
1	ISSUE FOR PERMITS	02/27/24							

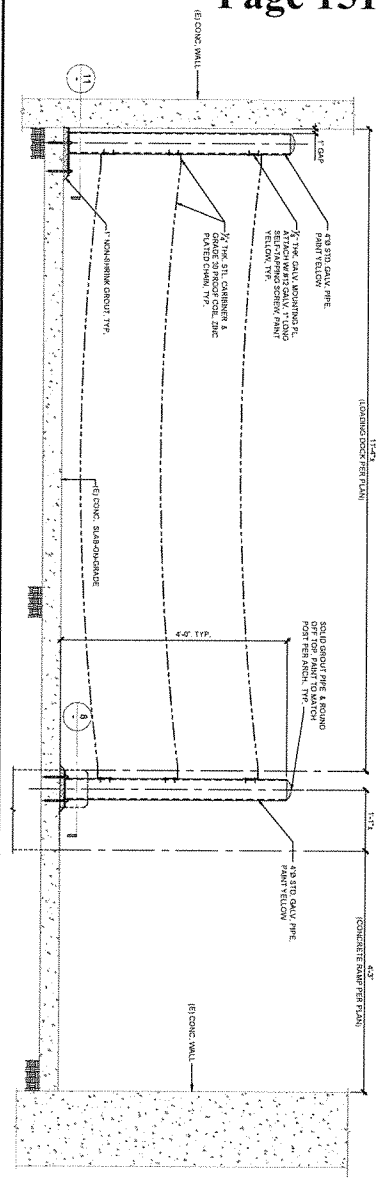

DOCK CHAIN BARRIER POLLARD  
 1" = 1/4"

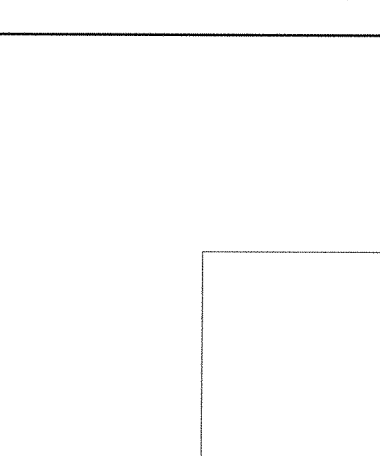

1" = 1/4"

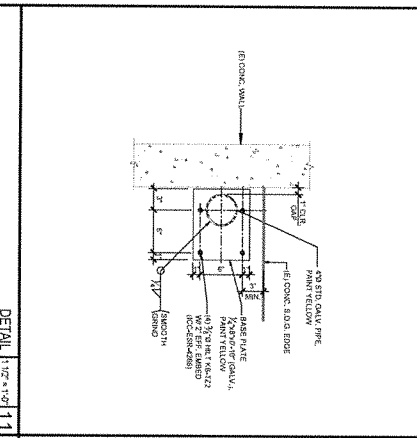

DETAIL  
 1 1/2" = 1/4"

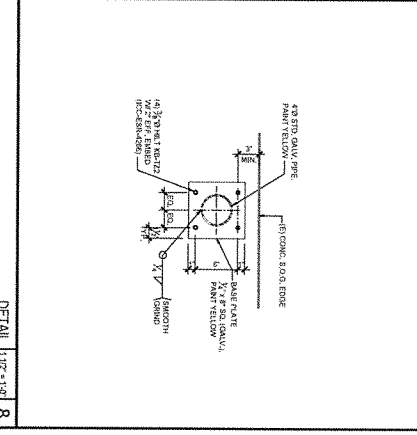

DETAIL  
 1 1/2" = 1/4"

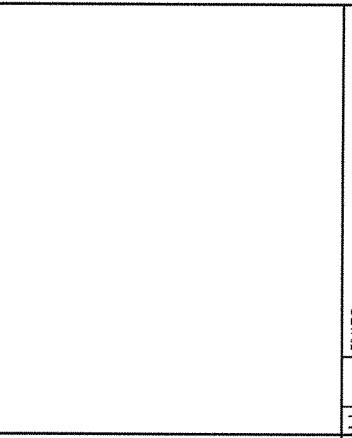

DETAIL  
 1 1/2" = 1/4"

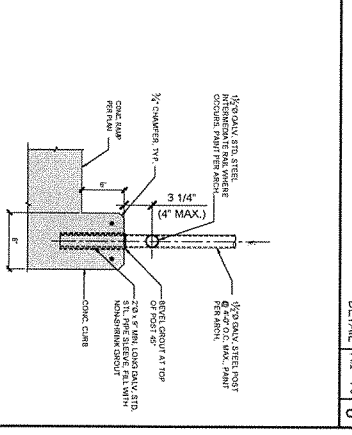

DETAIL  
 1 1/2" = 1/4"

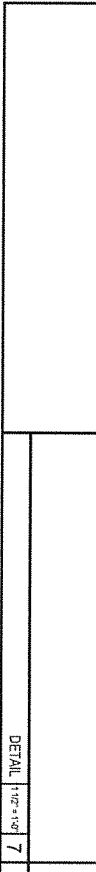

DETAIL  
 1 1/2" = 1/4"

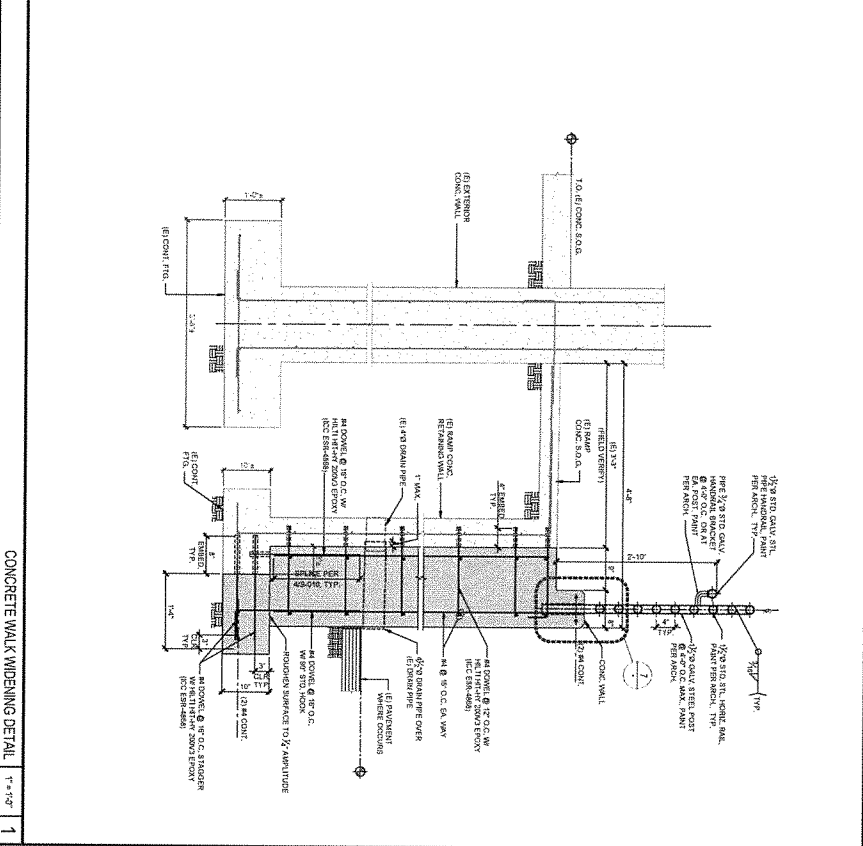

CONCRETE WALK WIDENING DETAIL  
 1" = 1/4"

CHECK



CLIENT LOGO AND ADDRESS AREA  
 411 E. CHAPMAN AVE  
 PLACENTIA, CA 92678

PROJECT NAME  
 LOADING DOCK  
 RAMP EXPANSION

411 E. CHAPMAN AVE  
 PLACENTIA, CA 92678



1 PETERS CANYON ROAD, SUITE 100  
 IRVINE, CA 92618  
 TEL: (949) 257-4800 FAX: (949) 257-0900



DATE REVISION DESCRIPTION

NO.	REV./ DESCRIPTION	DATE
A	PLANNING SUBMITTAL	09/20/24
B	PLANNING SUBMITTAL	09/20/24

PROJECT IDENTIFICATION  
 THIS DRAWING HAS BEEN PREPARED BY THE ARCHITECT AND THE ENGINEER HAS REVIEWED THE DRAWING FOR CONFORMANCE WITH THE PROFESSIONAL ENGINEERING ACT AND REGULATIONS AND THE ARCHITECT'S CONTRACT WITH THE ARCHITECT. IT IS NOT TO BE USED FOR ANY OTHER PROJECT WITHOUT THE WRITTEN PERMISSION OF THE ARCHITECT.

IDS PROJECT NO. 23X117.00  
 DRAWN BY CB  
 CHECKED BY CM, VAI  
 APPROVED BY SM

SHEET NAME  
 SECTIONS AND  
 DETAILS  
 SHEET NUMBER  
 S-501  
 SHEET NO. OF



Page intentionally left blank

---

---

**PLACENTIA LIBRARY DISTRICT BOARD OF TRUSTEES**

---

---

**TO:** Library Board of Trustees

**FROM:** Jeanette Contreras, Library Director

**SUBJECT:** **Closure Request for Staff Development Day on December 5, 2024**

**DATE:** August 26, 2024

**BACKGROUND**

There are two Staff Development Day (SDD) held annually which provides staff job-related continuing education opportunities through participation of various in-service training. The purpose of the Staff Development Day is to provide our staff with valuable learning opportunities, foster collaboration, and align our collective vision for the future. This day will enable our team to review our services and programs, and reinforce best practices to better serve our patrons.

The tentative agenda for the day includes a review of the strategic plan, and discussion of community survey conducted in Spring. Additionally, our team will use this time to prepare the building for the holidays. The December 5, 2024 will coincide with the City's Tree Lighting event and with the library closure on that day, will reduce parking challenges for the evening event.

We kindly request your approval to close on December 5, 2024 for the Staff Development Day.

**RECOMMENDATIONS**

1. Authorize a closure on December 5, 2024 for a Staff Development Day; and,
2. Roll Call Vote.



Page intentionally left blank

---



---

## PLACENTIA LIBRARY DISTRICT BOARD OF TRUSTEES

---



---

**TO:** Library Board of Trustees

**FROM:** Jeanette Contreras, Library Director

**SUBJECT:** **Presentation of the Community Survey Conducted February-April 2024**

**DATE:** August 26, 2024

### **BACKGROUND**

The purpose of this report is to present the findings from the recent community survey conducted to gather feedback on our library services. The survey aimed to assess community needs, satisfaction levels, and areas for improvement. The results will help inform our strategies and decisions to better serve our patrons.

### **Survey Overview:**

The survey was distributed online. It was open for responses from February to April 2024. In total, we received 350 responses from a diverse cross-section of our community, with 68% as Placentia residents. Ninety-eight percent of respondents are Placentia Library District cardholders. The largest respondents at 30% are over 65 years of age, with 25% respondents at the 35-44 age bracket, followed by 20% from respondents between the ages of 45-54.

### **Key Findings:**

#### **1. Library Usage:**

- **Frequency of Visits:** 57% of respondents visit the library at least once a month, while 43% visit once occasionally or less.
- **Popular Services:** The most frequently used services include:
  - Book borrowing 25%
  - Digital resources 15%
  - PLFF bookstore 11%
  - Special events 9%
  - Passport 7%
  - Children's Programs 6%

The following services were at the bottom of the survey, with less than 1% usage:

- History room
- Teen programs
- Adult literacy
- Meeting room rental

**2. Satisfaction Levels:**

- Collection (print materials) – 84% good to excellent ratings with 48% average
- Technology & Online Resources – 78% satisfied to very satisfied with 21% neutral
- Programs and Events – 78% satisfied to very satisfied with 21% neutral
- Areas for Improvement: The most expressed concerns included the need for additional parking, an outdoor space, 3D printers, coffee café, and a driver-side book drop.

**3. Community Needs:**

- Additional Services: More books and digital titles, workshops for adults and seniors, hotspots for circulation, coffee shop, 3D printers, better parking, easier drive by book return, job fair, author talks, and movie nights

**4. Customer Comments:****○ The Team**

- The staff at Placentia are genuinely friendly and accommodating even with the sometimes unusual demands of their clientele.
- The knowledge of the staff, they are very polite and helpful.
- How personal it is. I always feel welcome.
- Excellent librarians.
- Courteous people.
- The best staff
- Kind, helpful staff.
- Friendly staff.
- The kindness of the employees.
- Excellent helpful staff.
- The librarians are very friendly & helpful.
- Everyone who works there are so welcoming & helpful.
- The nicest people work there.
- Clean, friendly staff.
- The staff is the library's greatest asset.
- The staff is kind, responsive to emails, and are always willing to help.
- The staff is very helpful, kind, professional, patient, and provide thorough customer services to ALL patrons.
- The friendly staff who have been there since my kids were tiny, and the new staff members who are all very nice.
- I really like the director emails.
- The sincere desire of the board to keep the library relevant and useful – even entertaining.

**○ Facility / Operations**

- Convenient location.
- Warm and friendly environment.
- I love the children's space.
- The library district always seems to be engaging the community.
- It's very clean and quiet and has a nice children's play area.
- So many resources you wouldn't even think that the library offers.
- Traditional library – always evolving while retaining best historic services.



- I am a tremendous fan of Placentia Library District.
- It's clean and well organized.
- The Pretend City Space and the Monday Morning Meet Ups.
- No overdue fees.
- Open Sundays.
- Informative and engaging emails.
- Great selection of books, services, and programs.
- It has everything I want in a library. Clean and organized. Wide range of books and materials. Quiet place to read, study, and learn.
- The library has more services than any other I go to.
- The easiness and welcome that you feel there.
- It feels safe, friendly and clean.

The community survey has provided valuable insights into the needs and preferences of our patrons. By addressing the areas highlighted in this report, we can continue to improve our services and strengthen our role as an essential community resource. Our team will discuss feedback received at the next staff development day and forward recommendations for improvements to the Board at a future date.

Attachment A is the survey result.

**RECOMMENDATIONS:**

No action needed.

# Placentia Library District: Community Survey

**350**  
Responses

**07:46**  
Average time to complete

**Active**  
Status

## 1. Age

- Under 18
- 18-24
- 25-34
- 35-44
- 45-54
- 55-64
- 65+

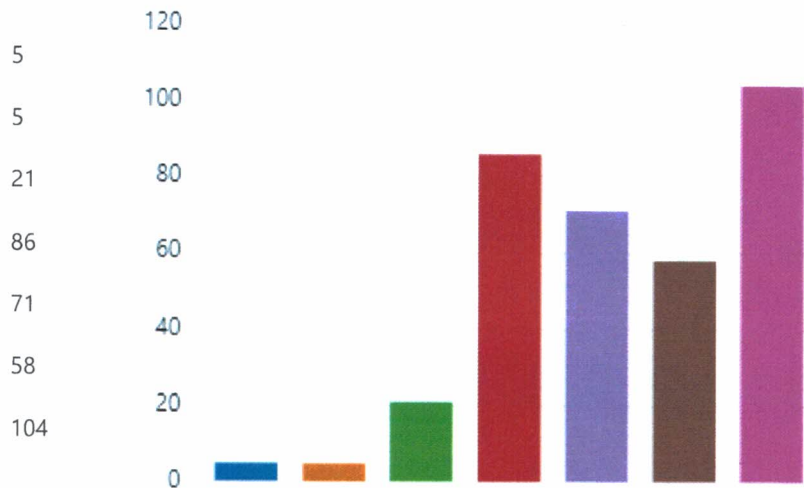

2. How long have you been a resident of Placentia?

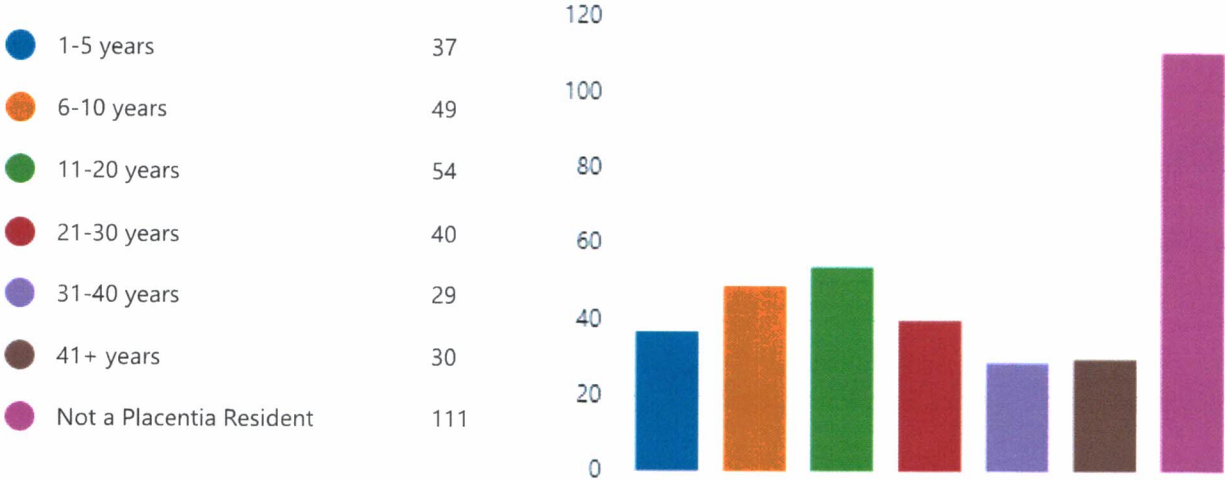

3. Do you have a library card for the Placentia Library District?

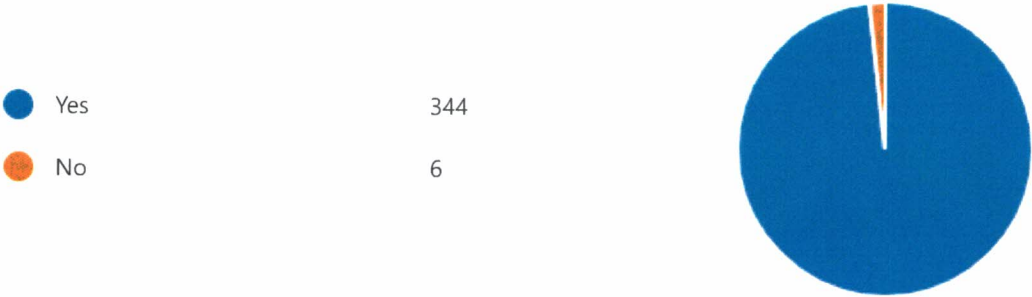

4. How often do you visit the library?

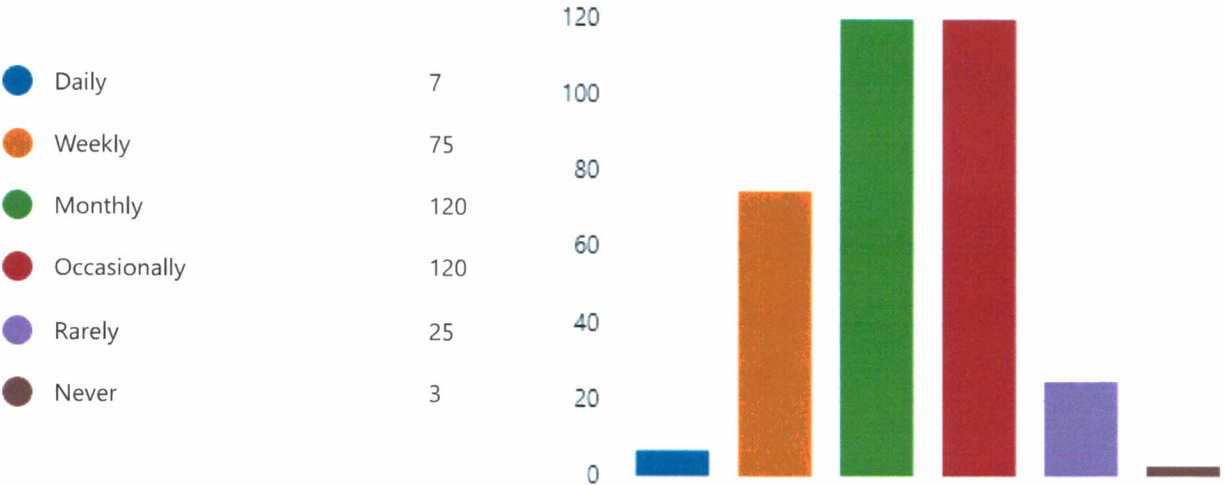

5. When was your last visit (in-person or virtual) to Placentia Library District?

**350**  
Responses

Latest Responses

"April 30,2024"

"4/30/24"

"A few weeks ago, beginning of April."

6. What other libraries do you visit often? When?

**350**  
Responses

Latest Responses

"None"

"Brea, Fullerton, Yorba Linda libraries."

"Fullerton, once a month"

7. What services do you most frequently use at the library? (Select all that apply)

● Books & materials	281
● Library of Things (LOTs)	64
● Online Databases	45
● eBooks/eAudiobooks	163
● Computer/Internet Access	23
● Research and Study	23
● History Room	8
● Children's Programs	73
● Teen Programs	10
● Adult Programs	60
● Special events (Summer Readin...	99
● Adult Literacy Services	11
● Passport Services	72
● Meeting Room Rental	13
● Bookstore	125
● Other	25

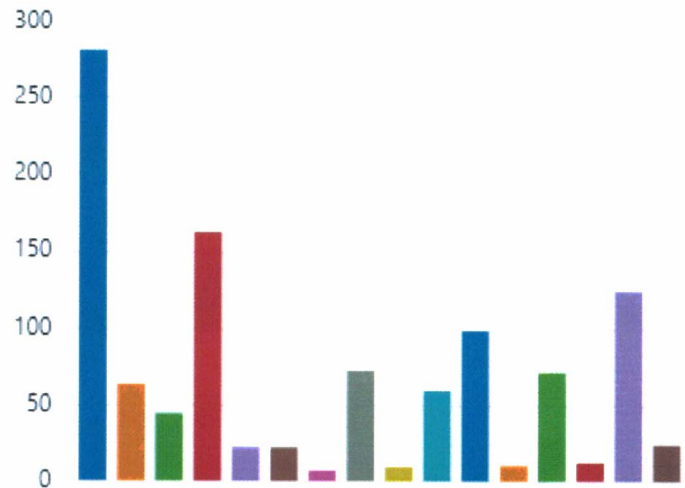

8. How would you rate the current collection of books and other materials at the library?

● Excellent	119
● Good	175
● Average	48
● Below Average	6
● Poor	2

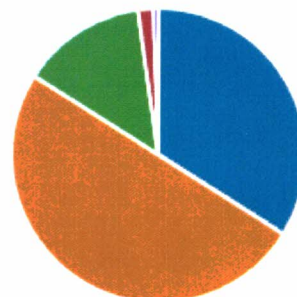

9. If you rated the current collection of books and other materials at the library below average or poor, please let us know how we can make it better for you.

52  
Responses

Latest Responses

10. How satisfied are you with the variety of programs and events offered by the library?

Very satisfied	149
Satisfied	124
Neutral	72
Dissatisfied	3
Very dissatisfied	2

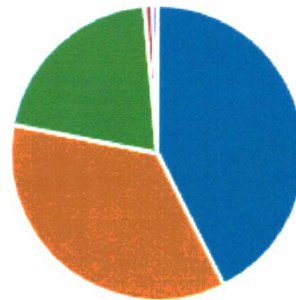

11. What types of programs or events interest you? (e.g., author talks, workshops, book clubs, movie nights)

350  
Responses

Latest Responses

"Author talks, volunteer opportunities "

"Literacy Program."

"We love reading to the dogs and bilingual story time."

12. How do you typically find out about library programs and events? (Select all that apply)

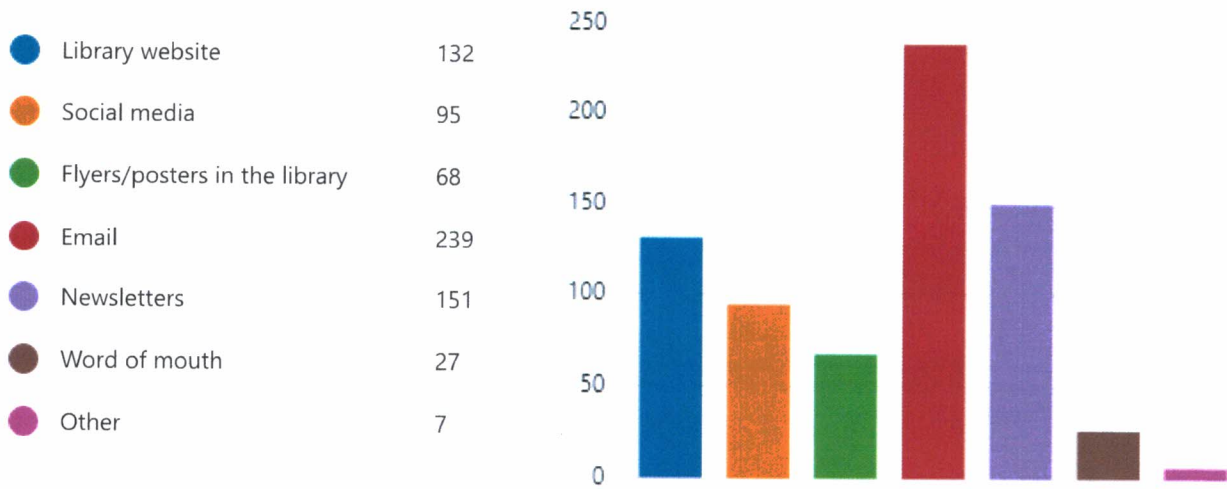

13. How satisfied are you with the technology and online resources available at the library?

Very satisfied	138
Satisfied	134
Neutral	73
Dissatisfied	4
Very dissatisfied	1

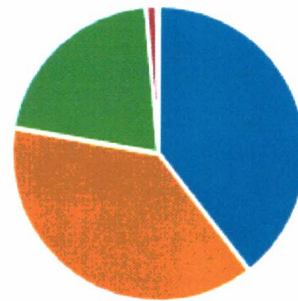

14. What additional technological resources or services would you like to see implemented at the library?

350  
 Responses

Latest Responses  
 "Can't think of anything "  
 "n/a."  
 "Not sure"

15. How likely are you to recommend Placentia Library District to a friend or family member?

Very likely	252
Likely	75
Neutral	20
Unlikely	1
Very unlikely	2

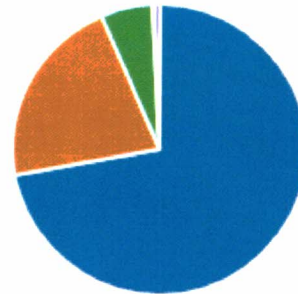

16. What do you appreciate most about Placentia Library District?

350  
Responses

Latest Responses

*"Friendly staff, library books and resources "*

*"Clean and well stocked in all sections."*

*"Community programs"*

17. What does our library currently not have that you wish it did?

350  
Responses

Latest Responses

*"Greater variety of downloadable ebooks"*

*"More nonfiction newer books."*

*"More authentic Spanish books (not just translations)"*

18. I would like to be contacted. Here is my name, phone number, and email address:

67  
Responses

Latest Responses

*"n/a."*



---

---

**PLACENTIA LIBRARY DISTRICT BOARD OF TRUSTEES**

---

---

**TO:** Library Board of Trustees  
**FROM:** Jeanette Contreras, Library Director  
**SUBJECT:** **Joint-Use Committee Updates from President Carline**  
**DATE:** August 26, 2024

**BACKGROUND**

President Carline will provide an update on the Joint-Use Committee meeting.

Attachment A is the August 8, 2024 meeting minutes.

MINUTES  
PLACENTIA LIBRARY DISTRICT  
MEETING WITH THE PLACENTIA LIBRARY DISTRICT AND THE CITY OF PLACENTIA  
AUGUST 8, 2024

**CALL TO ORDER**

**Members Present:** President Gayle Carline, Library Director Jeanette Contreras, City Administrator Damien Arrula, Councilmember Ward Smith, Councilmember Rhonda Shader, Deputy Director of Administrative Services Jeannette Ortega, Deputy Director of Community Services Veronica Ortiz.

**Staff Present:** Assistant Library Director Yesenia Baltierra, Executive Assistant Lina Nguyen, Senior Civil Engineer Gabriel Guerrero-Gabany.

**BACKGROUND**

By its terms, the Joint Use Agreement, or “JPA,” expired on May 21<sup>st</sup>, 2012. The District and City have now entered into a new agreement governing the use of the Common Area which was executed by notary on October 29<sup>th</sup>, 2019. The District and the City have continued to meet on a monthly basis to discuss ongoing and upcoming projects pertaining to the Common Area and shared costs.

**PARKING FOR ELECTRIC SCOOTERS**

Director Contreras reported a couple patrons had come by to request access to an area where they can charge their electric scooters. District policy dictates patrons cannot bring in items larger than a set size and these scooters were too large to be allowed into the library. These patrons claimed that by law, the District had to have an area where people can charge their electric scooters. She reached out to legal counsel who advised her there was no such law. Director Contreras asked if the City has any available outlets around the Civic Center for this. The City advised they do not. Councilmember Shader advised the City is about to tackle e-bikes on their upcoming Council meetings and will look into e-scooters.

**OVERNIGHT PARKING**

Director Contreras reported she has been seeing less overnight parking and wanted to thank the City and the Police Department for that. There were nights when the parking lot by the District would be full but she is no longer seeing that. City Administrator Arrula advised they are cracking down on the overnight parking. There will be more citations being issued due to the Police Department being fully staffed.

**PLACENTIA LIBRARY DISTRICT UPDATE**

Director Contreras reported there will be a PLFF membership recognition hosted in the District’s meeting room and part of the Civic Center on October 25th. She asked if the City can assist with the permits and forms necessary to host the event. Deputy Director Ortega and Deputy Director Ortiz advised they will reach out to City staff who are well informed about these permits and forms and get them in contact with the District. Director Contreras also reported the Summer Reading Program is ending on August 10th; there is a planned closure for Staff Development Day that will coincide with the City’s Christmas Tree Lighting; the District received two privacy booths that will be opened to the public soon; and the District completed a community survey and will share a report with the City at a later time.

She took this time to thank the City for their assistance with the City inspection portion of the Outdoor Project. The District Board has approved to enter into a contract with a project manager, who is working on a RFP for Board approval this month. She is hoping the project will be finished by December of this year.

**CITY OF PLACENTIA UPDATE**

City Administrator Arrula reported there was a grand jury report on mental health training for law enforcement and recyclables in organic waste.

Councilmember Shader reported the council will not be meeting this month.

Councilmember Smith reported that they received a check from Michelle Steel for their Public Safety Center project. City Administrator Arrula advised the center will be finished December of this year.

The City advised they are also working on a huge paving project; they are finalizing things for the Senior Center project; they are continuing their Parks Initiative projects in La Placita Parkette, McFadden Park, and Jaycee Parkette; they are installing 50 wayfinding signs throughout the city; the Salvation Army is the new operator for the navigation center; and the Taste of Placentia is next Thursday.

City Administrator Arrula took this time to report the City is putting together an ad-hoc committee which will be tasked with coming up with a plan for the City's centennial. The City is planning on a year-long celebration.

**ACTION ITEMS**

Deputy Director Ortega and Deputy Director Ortiz will connect the District to City staff who can help with event permits and forms.

Senior Civil Engineer Guerrero-Gabany will connect with City Engineer Chris Tanio to provide the District with the assessment that includes information on the electrical panels.

**NEXT MEETING**

The next meeting has not been scheduled yet. However, please email Lina Nguyen with any items you would like to add to the agenda.



Page intentionally left blank

---

---

**PLACENTIA LIBRARY DISTRICT BOARD OF TRUSTEES**

---

---

**TO:** Library Board of Trustees

**FROM:** Jeanette Contreras, Library Director

**SUBJECT:** Roundtable Women's Club Updates from Secretary Dahl

**DATE:** August 26, 2024

**BACKGROUND**

Secretary Dahl will provide an update from the Roundtable Women's Club.



Page intentionally left blank

---

---

**PLACENTIA LIBRARY DISTRICT BOARD OF TRUSTEES**

---

---

**TO:** Library Board of Trustees  
**FROM:** Jeanette Contreras, Library Director  
**SUBJECT:** LAFCO Updates from Trustee Beverage  
**DATE:** August 26, 2024

**BACKGROUND**

Trustee Beverage will provide an update on LAFCO activities.



Page intentionally left blank



---

---

**PLACENTIA LIBRARY DISTRICT BOARD OF TRUSTEES**

---

---

**TO:** Library Board of Trustees

**FROM:** Jeanette Contreras, Library Director

**SUBJECT:** ISDOC & Legislative Updates from Trustee Nelson

**DATE:** August 26, 2024

**BACKGROUND**

Trustee Nelson will report out on ISDOC meeting activities and the CSDA Legislative Days efforts.

Attachment A is the 2024 Mid-Year Legislative Report from CSDA.



CSDA

California Special  
Districts Association  
*Districts Stronger Together*

Agenda Item 32  
Attachment A  
**Page 174**

## Significant Legislative Highlights

### Bill Report

# 2024 Mid-Year Legislative Report

**Disclaimer:** This publication is provided for general information and is not offered or intended as legal advice. Readers should seek the advice of an attorney when confronted with legal issues and attorneys should perform an independent evaluation of the issues raised in these materials.





# 2024 Mid-Year Legislative Report

## Table of Contents

Significant Legislative Highlights ..... Page 3  
Bill Report..... Page 11





## **2024 MID-YEAR LEGISLATIVE REPORT: *The Voice of Special Districts***

---

In the second year of the 2023-2024 Legislative Session, the California State Legislature introduced and CSDA reviewed 2,464 measures. CSDA's Legislative Committee adopted positions on 1,491 bills and other measures, including 128 priority positions, such as support, support if amended, oppose, oppose unless amended, concerns, and neutral positions following amendments.

Important measures on which CSDA has been engaged include:

### **AB 2631 (M. Fong) Local agencies: ethics training.**

- CSDA co-sponsored this bill to provide the Fair Political Practices Commission with the statutory authority to provide free ethics training to public agency officials. This bill is necessary so that the Commission can be provided with the requisite appropriation from the state to make changes to the course platform.
  - This measure is co-sponsored along with the California State Association of Counties and the League of California Cities.

### **ACR 163 (Hart) Special Districts Week.**

- CSDA sponsored this resolution to continue to spotlight the value of the essential local services provided by special district members.
  - The resolution proclaimed the week of May 19, 2024, to May 25, 2024, to be Special Districts Week.
  - This resolution builds on resolutions from previous years, in which the Legislature had similarly encouraged all Californians to be involved in their communities and be civically engaged with their local government.

### **SB 1164 (Newman) Property taxation: new construction exclusion: accessory dwelling units.**

- This bill would have exempted accessory dwelling units (ADUs) from property taxation until either: 1) 10 years passed since the completed construction of the unit, 2) there was a subsequent change in ownership of the accessory dwelling unit, or 3) the unit was converted to any use other than for residential housing.
  - CSDA worked with coalition members including the California State Association of Counties, League of California Cities, California Teachers Association, Urban Counties of California, and Rural County Representatives of California to oppose this elimination of vital property tax revenue used to fund essential local services. Estimates from the Board of Equalization predicted the loss of \$20 million annually in property tax revenue if the bill were made law.
  - SB 1164 will not be moving forward this session, after the author pulled the bill from consideration in the Assembly.





**California Special  
Districts Association**

*Districts Stronger Together*

***Additional Local Revenue:***

CSDA has worked to protect special district revenues, supporting legislation to ensure their stability and protect agencies from costly litigation, and opposing legislation which would reduce revenues.

- **[Administration's Charter Schools Educational Revenue Augmentation Fund \(ERAF\) Trailer Bill Proposal](#)** - CSDA joined with the Urban Counties of California, Rural County Representatives of California, California State Association of Counties, League of California Cities, County of San Mateo, County of Marin, and County of Napa in opposing a proposal from the Newsom Administration that sought to insert charter schools into the calculation and distribution of monies in each county's ERAF, thereby reducing potential excess ERAF returns to local agencies, including special districts. The proposal was rejected by the Legislature and was not included in the relevant budget bills, Assembly Bill 164 or Senate Bill 164.
- **[AB 1827 \(Papan\)](#)** - CSDA joined a coalition in support of this measure that seeks to ensure water service providers can adequately capture the cost of service. This bill would permit the inclusion of the incrementally higher costs of water service due to the higher water usage demand of parcels, the maximum potential water use, projected peak water usage, or any combination of those factors in the fees or charges for property-related water service.
- **[AB 2257 \(Wilson\)](#)** - CSDA joined local agency stakeholders in supporting this legislation that would reduce agencies' exposure to adverse judicial intervention by requiring a potential litigant to participate in the Proposition 218 rate-setting process, provided the agency abides by specified procedures established by the bill.
- **[SB 1072 \(Padilla\)](#)** - CSDA and coalition partners are advocating for this legislation that ensures agency revenues are not exposed to disruptive Proposition 218 remedies incompatible with agency finance structures. The bill would provide that, if a court determines a certain charge was unlawful, the appropriate remedy would be to apply any excess fees collected toward reducing the cost for the agency to provide that service moving forward.

***Housing and Development Related Fees Legislation:***

Several legislative measures were introduced in 2024 that propose restrictions on development-related fees. CSDA is actively collaborating with other local government advocates to oppose these measures either partially or entirely, and to educate legislators and their staff on the importance of the Mitigation Fee Act, development impact fees, the Quimby Act, and connection and capacity charges.

- **[SB 937 \(Wiener\)](#)** - CSDA led a coalition of local government partners in opposing unless amended this measure that, among other things, for certain project types of residential developments, would generally prohibit the collection of interest on impact fees that are deferred until the completion of a development at final inspection or certificate of occupancy. It would also lock those fees in when the development is approved and is eligible to pull a building permit. Amendments were recently added that included a 5-year cap on deferral of fees if a permitted project has not broken ground.



**California Special  
Districts Association**

*Districts Stronger Together*

- [AB 2729 \(Patterson, Joe\)](#) - CSDA formed a coalition of local government partners to oppose this measure that, among other things, would require development impact fees be the same amount as would have been paid had the fees and charges been paid prior to the issuance of building permits and the local agency shall not charge interest or other fees on any amount deferred. The measure has a provision to collect the fees earlier in the process but would require that the local agency begin the improvements within 24 months. This measure has been proposed to be amended in its last committee to narrow the types of developments it applies to.
- [SB 1210 \(Skinner\)](#) - While introduced as a measure to cap utility-related development fees, this bill was dramatically amended to only require all utilities, both private and public, to post a schedule of fees for a service connection, capacity, or other point of connection charge for each housing development type. However, this paragraph does not apply to a utility that continues to post a schedule of their fees in accordance with existing law. With these amendments CSDA and its partners moved from an oppose position to a neutral position.
- [AB 3068 \(Haney\)](#) - This measure will create the Adaptive Reuse Investment Incentive Program to incentivize converting existing buildings into residential or mixed-use developments. Among other things, it only allows impact fees directly related to the impacts resulting from the change of use of the site from nonresidential to residential or mixed use. Any fees charged shall be proportional to the difference in impacts caused by the change of use and be collected on the date the certificate of occupancy is issued. The bill has contractual protections for those deferred fees. The author accepted committee amendments that would strike the provision that impact fees can only be collected at certificate of occupancy and change the verbiage regarding fees that can be assessed from "direct" impacts and "proportional" to language that reflects "reasonably related" and "roughly proportional." CSDA changed its position from oppose unless amended to neutral after those amendments.
- [AB 1820 \(Schiavo\)](#) - After numerous positive amendments, this bill would now authorize a development proponent that submits a preliminary application for a housing development project per Senate Bill 330 guidelines to request a preliminary fee and exaction estimate for cities and counties, and fee schedules for special districts and schools. Additionally, after an application is approved and is eligible to pull building permits, the bill would require all local agencies to provide the development proponent with a total sum amount of all fees and exactions that will apply to the project with 30 business days. The total sum is a good faith estimate for informational purposes and is not legally binding on the agency. The bill has been amended in other respects which are beneficial to special districts. With the totality of amendments, CSDA and its partners moved from opposed to neutral.

**Brown Act:**

CSDA, having previously led several efforts to make changes to the Brown Act, has remained engaged in legislative efforts to reform the state's open meeting laws, including:

- [AB 817 \(Pacheco\)](#) - CSDA joined several local government stakeholders in supporting AB 817, which sought to make service on public agency advisory bodies more





**California Special  
Districts Association**

**CSDA**

*Districts Stronger Together*

accessible by providing more flexibility to members to participate remotely. Faced with amendments antithetical to the bill's intent, AB 817 failed to advance out of the Senate Local Government Committee.

- [AB 2302 \(Addis\)](#) - CSDA has supported this bill which seeks to clarify that separate convenings of an agency in a single calendar day amount to a single "meeting" under the Brown Act, recasting existing limits on the number of times members of a legislative body can participate remotely in meetings for just cause or emergency circumstances.

**Surplus Land Act (SLA):**

CSDA remains a leader in connection with the SLA and Department of Housing and Community Development (HCD) efforts to update guidelines implementing the SLA.

- [HCD Draft Updated SLA Guidelines](#) - In 2023, Governor Gavin Newsom signed two laws that made several changes to the requirements of the SLA, [AB 480 \(Ting\)](#) and [SB 747 \(Caballero\)](#), with both laws taking effect on January 1, 2024. CSDA led coalitions on both bills. Following the recent enactment of AB 480 and SB 747, HCD released its Draft Updated Surplus Land Act Guidelines issued February 23, 2024 (Draft Updated Guidelines). The Draft Updated Guidelines (and current guidelines) are inconsistent with the statute and may result in operational challenges for special districts. As a result, CSDA issued a Call to Action to its members, and submitted a lengthy [comment letter to HCD](#). The Draft Updated Guidelines are still in process and have not yet been adopted in final form.
- [SB 1134 \(Caballero\)](#) - In response to HCD's Draft Updated Guidelines, this measure was amended to remove HCD's exemption from the Administrative Procedures Act related to SLA rulemaking. Instead, the measure would require that: "Any rule, policy, or standard of general application issued by the Department of Housing and Community Development in implementing this article shall be subject to the rulemaking provisions of the Administrative Procedure Act..." CSDA and partner associations maintain a support if amended position on the bill, to address an error.

**Labor and Employment:**

High vacancy rates at local government employers have given rise to several measures which may negatively impact special district operations and unnecessarily increase expenses. The bills on which CSDA has been most engaged, include:

- [AB 2557 \(Ortega\)](#) - This bill burdens the process for local governments and schools to contract out for statutorily authorized special services by requiring onerous website reporting obligations, contract requirements, and notifications. The bill is expected to disincentivize contractors from doing business with local agencies and increase costs and delays. CSDA is a leader of the local government coalition opposed to the bill.
- [AB 2489 \(Ward\)](#) - A companion to AB 2557, this measure would burden the process for local governments and schools to contract out for statutorily authorized special services by requiring contractors to use employees who meet or exceed the minimum qualifications and standards required of bargaining unit civil service employees who perform or performed the same job functions, and by exposing contractors' employee



**California Special  
Districts Association**

*Districts Stronger Together*

data. The bill was expected to disincentivize contractors from doing business with local agencies and increase costs and delays. CSDA was a leader of the local government coalition opposed to the bill, which was held on the Assembly Appropriations Committee Suspense File and will not be advancing this year.

- [AB 2561 \(McKinnor\)](#) - This bill would require a local agency with high vacancy rates to, upon request by the recognized employee organization, meet and confer and hold a public hearing, regarding the high vacancy rates and strategies to reduce them.

CSDA has also been highly engaged on other labor and employment legislation which may have adverse impacts on special districts' ability to provide essential services or maintain safe workplaces. The bills on which CSDA has been most engaged include:

- [AB 2404 \(Lee\)](#) - This bill would provide protections for employees to engage in sympathy striking and remove sympathy striking from bargaining. This bill was similar to AB 504 (Reyes, 2023), which was opposed by CSDA and vetoed by Governor Newsom. CSDA has an oppose position on AB 2404, and was working with a local government coalition to oppose and amend the bill. The bill was held on the Assembly Appropriations Committee Suspense File and will not be advancing this year.
- [SB 1116 \(Portantino\)](#) - This bill would provide unemployment benefits to workers who are currently employed, and not seeking other employment, but who are on strike. This bill is a reintroduction of SB 799 (Portantino, 2023), which was opposed by CSDA and vetoed by Governor Newsom. CSDA led the local government coalitions opposing the 2023 and 2024 versions of the bill. SB 1116 failed passage in the Assembly Insurance Committee.
- [AB 2751 \(Haney\)](#) - This bill would require employers to institute a workplace policy granting employees the right to disconnect from employer communication during nonworking hours, with exceptions, and establish enforcement mechanisms. The bill exempts employees covered by valid collective bargaining agreements. The bill was held on the Assembly Appropriations Committee Suspense File and will not be advancing this year.
- [SB 399 \(Wahab\)](#) - This two-year bill will prohibit employers from taking action against employees who decline to participate in employer-sponsored meetings or receive communications, the purpose of which is to share the employer's opinion about political or religious matters. CSDA is leading a local government coalition with an oppose position on the bill because of its unique impacts on local government workplaces where routine activities may be regarded as political matters.
- [AB 2421 \(Low\)](#) - With limited exceptions, this bill would prohibit a public employer from questioning any employee or employee representative regarding communications made in confidence between an employee and an employee representative in connection with representation relating to any matter within the scope of the recognized employee organization's representation. CSDA is leading a local government coalition with an oppose position on the bill.





**California Special  
Districts Association**

*Districts Stronger Together*

**SB 252 (Gonzalez): Public retirement systems: fossil fuels: divestment.**

- This two-year bill would require CalPERS and CalSTRS to divest from fossil fuel companies. CSDA led a coalition with an oppose position on the bill because investment decisions should be left to the CalPERS Board of Administration, and because of the detrimental impacts of divestment on employer contribution rates. The bill will not advance this year after the author declined to accept amendments proposed by the Assembly Public Employment and Retirement Committee.

***Public Works:***

CSDA and its coalition partners have been actively involved with several public works bills this year. The bills on which CSDA has been most engaged include those impacting prevailing wage, gate safety standards, and cost accounting standards.

- **AB 1890 (Patterson, Joe)** - This bill requires the awarding body of a public works contract to provide notice to the Department of Industrial Relations if there is a change in the identity of a contractor or subcontractor performing the project or, within 30 days, if the total amount of the contract change exceeds \$10,000. CSDA has an oppose unless amended position and has engaged with the author, the sponsors and other local government advocates to seek positive amendments to the bill.
- **AB 2149 (Connolly)** - CSDA has joined with other local government advocates to oppose this measure that creates a framework for the inspection and repair of "regulated gates," imposes administrative fines for violations, and declares unrepaired and dangerous gates to be a public nuisance. A regulated gate is defined as any gate that weighs more than 50 pounds and is more than 48 inches wide or more than 84 inches high that is located in an area that is intended to be used by the public, an entire community or neighborhood, or any considerable number of persons. The gate has to meet several requirements and standards including a positive stop. The bill would require the owner of a regulated gate to have it inspected on or before July 1, 2026, and have it reinspected at least once every 10 years by a professional or qualified employee to ensure that the regulated gate complies with the requirements. Gate-owner includes all state and local agencies.
- **AB 2182 (Haney)** - CSDA is opposing this measure that makes numerous changes to state public works law including authorizing the Director of Industrial Relations (Director) to dismiss the request of a contractor or subcontractor for a review of a civil wage and penalty assessment due to the contractor's or subcontractor's failure to appear for a prehearing conference or hearing and granting joint labor-management committees (JLMCs) reasonable access to public works job sites. The bill requires, among other things, that if during any semiannual period the Director determines there has been a change in any prevailing wage rate in any locality, the Director will make such change available to the awarding body and the Director's determination will be final. Such determination shall apply on its effective date to any contract that is awarded, or for which notice to bidders is published after July 1, 2025.



**California Special  
Districts Association**

*Districts Stronger Together*

- [AB 2192 \(Carrillo, Juan\)](#) - CSDA is supporting this measure, that would increase project cost limits specified in the Uniform Public Construction Cost Accounting Act (CUPCCA) and separate the negotiated contracts and purchase order limits from the force account limits. This bill also refines the oversight authority of the CUPCCA Commission. This bill includes increasing the dollar amount of projects that may be performed pursuant to CUPCCA by the employees of a public agency by force account order from \$60,000 to \$70,000 and separating the negotiated contracts and purchase order limits from the force account limits while setting the new limit for these procurements at \$100,000. It also increases the dollar amount of projects that are subject to CUPCCA's informal bidding procedures from \$200,000 to \$220,000 and increases the dollar amount of projects that are subject to CUPCCA's formal bidding requirements from \$200,000 to \$220,000, among other technical changes.

**California Air Resources Board (CARB) Advanced Clean Fleets (ACF) Regulation:**

In April 2023, CARB passed its ACF regulation, which requires local government medium and heavy-duty fleets to transition to Zero-Emission Vehicles (ZEVs). The ACF regulation became effective as of October 1, 2023. The regulation calls for a transition to ZEV purchase schedule: Beginning January 1, 2024, 50 percent of the total number of vehicles purchases for the California fleet made in each calendar year must be ZEVs, and starting January 1, 2027, 100 percent of purchases for the California fleet in each calendar year must be ZEVs. CSDA advocated directly with CARB members and staff, provided written comments, and testified in opposition to the regulation during the public hearing, citing timeline, cost, infrastructure and emergency response concerns.

CSDA is now engaging in related efforts which may help special districts preparing for this monumental transition, including:

- [Climate Resilience Bond 2024](#) - CSDA along with its city and county partners has advocated for up to \$500 million of any potential Climate Resilience Bond to be targeted at the infrastructure and vehicles for local agencies to comply with the ACF / ZEV mandate. At this time, it appears the Climate Resilience Bond will not directly include this request.
- [AB 173 \(Committee on Budget\)](#) - California Department of Transportation (Caltrans) sought approximately \$250 Million to comply with ZEV mandates. Working closely with city and county partners, CSDA was able to advocate for adding reporting language to this Caltrans transportation budget trailer bill. This language requires Caltrans to annually compile and report information to the Legislature regarding the ZEVs the department purchases, owns, or leases. This will help all public agencies to gain valuable insights on how infrastructure and vehicle acquisition mandates can be addressed.
- [AB 637 \(Jackson\)](#) - CSDA is supporting this bill which would allow a fleet owner that rents a ZEV or ZEVs for a cumulative total of 260 days in a calendar year to be deemed as having ownership of one ZEV for purposes of meeting the ACF mandate.





**California Special  
Districts Association**

*Districts Stronger Together*

- o [SB 1393 \(Niello\)](#) - CSDA supported this measure which would have provided for an appeals committee when a local agency is denied a request for an exemption from the ACF / ZEV mandates. The proposed committee would review appeals of denied requests for exemptions from the requirements of the ACF regulation and make recommendations to the state board with respect to the denial of the exemption request. This measure failed to advance.
- o [AB 2266 \(Petrie-Norris\) and SB 1387 \(Newman\)](#) - CSDA held support positions on these very similar measures which sought to expand eligibility for the Hybrid and Zero-Emission Truck and Bus Voucher Incentive Project (HVIP) to include a ZEV exceeding 8,500 pounds that is either purchased for fleet operations by a public or private fleet or by an individual for personal and (substantially in furtherance of) commercial use. These measures would have defrayed some costs of acquisition of certain ZEVs and allowed local agencies to apply for a voucher (currently \$7500 for a vehicle of this type) from the state for the purchase of a broader selection of ZEVs, including pick-ups. AB 2266 failed to advance, while SB 1387 remains pending.

CSDA remains hard at work advancing the interests of special districts in the Legislature. Interim Recess, beginning upon adjournment on July 3, marks the deadline for each house to pass bills out of their respective policy committees. The Legislature will return on August 5 and complete the session by August 31. Stay tuned to CSDA eNews and Advocacy News for future updates.



**California Special  
Districts Association**  
*Districts Stronger Together*

---

**2024 MID-YEAR LEGISLATIVE REPORT: *The Voice of Special Districts***

---

A report of bills tracked by CSDA with priority positions can be [viewed at this link](#)

The report provides links to each of the tracked measures, together with CSDA Summaries, copies of letters submitted to the Legislature by CSDA, and other pertinent information concerning bill status. The report lists CSDA's position on each bill.

The report lists the lobbyist assigned to each bill. For additional information on a particular bill, please contact the assigned lobbyist: Director of State Legislative Affairs Aaron Avery at [aarona@csda.net](mailto:aarona@csda.net); Legislative Representative Marcus Detwiler at [marcusd@csda.net](mailto:marcusd@csda.net); and, Legislative Representative Anthony Tannehill at [anthonyt@csda.net](mailto:anthonyt@csda.net).

General questions can be directed to Aaron Avery.